

THE AMERICAN MINERALOGIST

JOURNAL OF THE MINERALOGICAL SOCIETY OF AMERICA

VOL. 8

FEBRUARY, 1923

No. 2

THE USE OF PLANS AND ELEVATIONS IN THE STUDY OF GEOMETRICAL CRYSTALLOGRAPHY¹

AUSTIN F. ROGERS, *Stanford University*

WITH DRAWINGS BY P. I. AGUERREVERE AND S. E. AGUERREVERE

In making crystal drawings it is customary to use clinographic or oblique projections. These drawings are probably the most satisfactory for descriptive purposes in articles and text-books, for they give the appearance of solidity. Clinographic projections, however, are rather difficult to draw and take too much of the student's time to be used in elementary class work. Yet it seems advisable for the student to employ some form of crystal drawing in order that he may gain an adequate idea of the geometry of crystals.

Orthographic projections, either plans or plans combined with clinographic projections, have been used widely, but little use has been made of combined plans and elevations, simple though they are. The student can make a plan and an elevation of a crystal, if not too complex, in a comparatively short time, and from these two drawings it is possible to determine graphically the axial elements of the crystal and the Miller indices of the forms. The method is simple and direct as compared with other methods such as the stereographic or gnomonic projections which of course are to be preferred for advanced work.

The writer has found that graphic methods based upon plans and elevations furnish the best solution of the rather difficult problem of teaching geometrical crystallography to students in elementary mineralogy. Measurements of typical crystals from 2 to 6 cm. or so in size are made with the contact goniometer, and from these measurements the plan and one or more elevations are

¹Paper presented at the annual meeting of the Mineralogical Society of America, Amherst, Mass., Dec. 29, 1921.

constructed. An advantage of the contact goniometer over the reflection goniometer is that measurements are possible between edges as well as faces.

In constructing plans and elevations it is necessary, or at least advisable, to employ the methods of descriptive geometry. The third angle or quadrant is used so that the plan appears above the elevation instead of below it as in the first angle projection.²

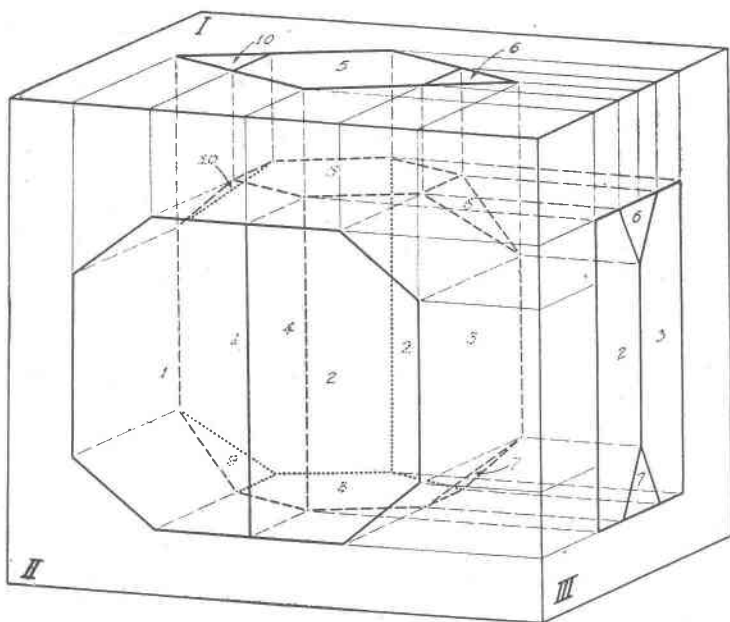

S.E.A. del.

FIGURE 1. STEREOGRAM SHOWING CLINOGRAPHIC PROJECTION OF AN ORTHORHOMBIC CRYSTAL AND ORTHOGRAPHIC PROJECTIONS ON THREE AXIAL PLANES I, II, AND III.

If more than one elevation is drawn, the seventh octant is used. This is illustrated in Fig. 1, which is a stereogram of an orthorhombic crystal and its orthographic projections on the three axial planes I, II, and III drawn in clinographic projection. The

²A good argument for this method is found in the drawing of hemimorphic crystals such as tourmaline in which case the plan of the upper end of the crystal will appear above the elevation and the plan of the lower part below the elevation.

method of producing the plan and elevations is shown in this stereogram. Lines (fine dotted) are drawn from the vertices of the crystal normal to the axial planes and thus the three orthographic projections are produced. These three projections are connected each with each as shown by fine solid lines.

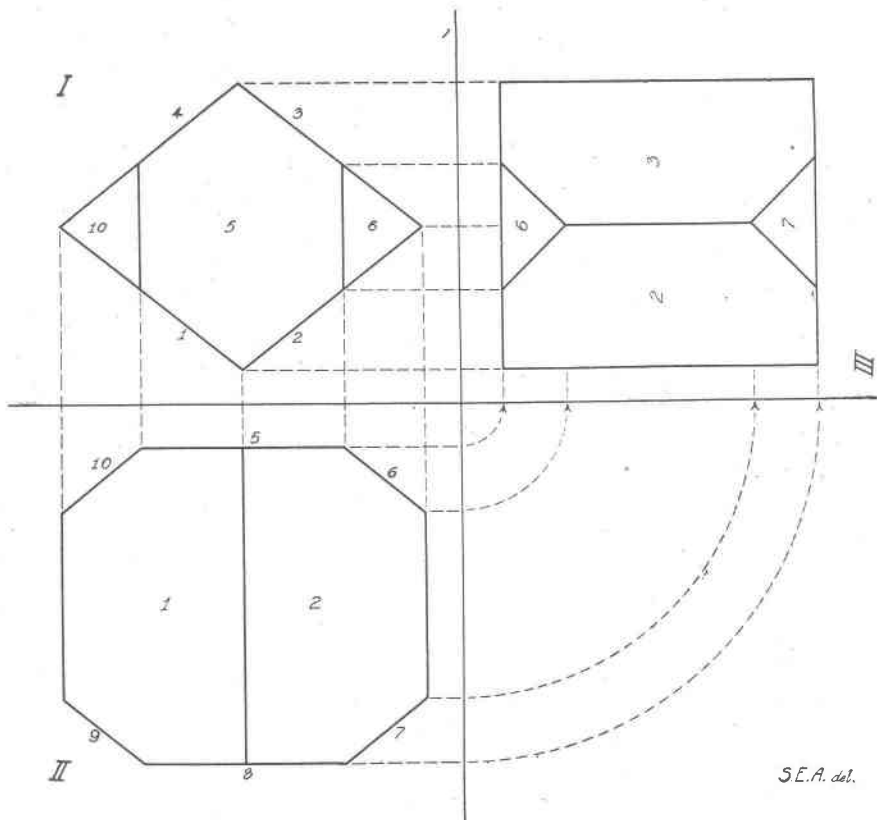

S.E.A. del.

FIGURE 2. PLAN (I), FRONT ELEVATION (II), AND SIDE ELEVATION (III) OF THE ORTHORHOMBIC CRYSTAL SHOWN IN FIGURE I.

Fig. 2 shows the plan, front elevation, and side elevation folded out as they appear in actual practice. The drawings are made by measuring and plotting interfacial angles. For example, the plan I is drawn from the interfacial angles 1:2, 2:3, 3:4, and 4:1. For the front elevation II, the interfacial angles 5:6, 5:10, 7:8, and 8:9 are necessary. The side elevation III is produced by the intersection of lines from the vertices of the plan with those from the front

elevation after swinging them through arcs of 90° . Corresponding vertices in each elevation are the same distances from the folding lines, which makes possible the construction of any number of elevations after one of them is drawn. The two elevations are as closely related to each other as the plan and elevations are.

Illustrations of orthographic projections of ideal³ crystals of five of the six crystal systems are shown in Figs. 3-7.⁴ (The triclinic system is so difficult that it may well be omitted in elementary work.) In these drawings, full lines represent edges of crystals; dotted lines, construction lines; and dot-and-dash lines, axes of reference.

In this article the term *plan* is used for an orthographic projection in which the *c*-axis of the crystal appears as a point. An *elevation* is an orthographic projection in which the *c*-axis appears in its full length. A *front elevation* is an elevation in which the *b*-axis appears in its full length and a *side elevation* one in which the *a*-axis appears in its full length. Other elevations, for the want of a better name, may be called *angular elevations* and may be designated by the (*hk*0) face to which the new folding line is normal.⁵ For example, the right-hand drawing of Fig. 3 may be called an (110) elevation.

In the descriptions a face is designated by the letter indicated in the drawing.⁶ Since edges are formed by the intersection of two faces they may be designated by the two letters and, similarly, vertices may be designated by the three or more letters of the faces which form the vertex.

Orthographic projections are not confined to plans and elevations. A *supplementary projection* may be made from any elevation by establishing a new folding line. Construction lines are drawn from the points of the elevation normal to the folding line. The vertices in the new drawing are the same distances from the

³ In practice the various faces would be shown in their actual development.

⁴ Other examples are given in the writer's *Introduction to the Study of Minerals and Rocks*, (pp. 97, 101, 111, 115, 120, and 123),¹2nd edition, 1921.

⁵ It is well in every case to have the folding line normal to a crystallographically possible face.

⁶ The method of designating various faces of a form is the same as that given in Dana's *System of Mineralogy*, 6th edition, 1892.

The plan, or as much of it as is possible, is first drawn from the interfacial angles mm'' , ml , lb , bl' , $l'm'$, etc. The edge yf is parallel to the edge ff' and the edge fo is normal to the edge ff' . The edges ou and ui are parallel to the edge om , but the edges uf and if cannot be drawn until the elevations are made.

Next the angular elevation on the right is made on construction lines parallel to the edge om by plotting the interfacial angles mo , ou , ui , and the corresponding ones on the opposite side of the crystal. (An angular elevation is made instead of a side elevation because in the latter case no interfacial angles can be measured). The edges fl , ly , $l'y$, and fl' , cannot be drawn until the front elevation is made.

The front elevation is produced by plotting the interfacial angles by , yf , ff' , $f'y'$, and $y'b'$. The edges bl , lm , etc. are normal to the folding line and the edges om , ou , and ui , parallel to the folding line. The distances of the vertices omf , uof , and iuf are the same distance below the folding line in the front elevation as in the angular elevation. The intersection of construction lines from these points in the front elevation with those from the angular elevation give us the points uof and iuf in the plan and thus the plan may be completed.

And in a similar way the angular elevation may be completed by establishing the vertices lyf , lyb , $l'yb$, and $fy'l'$ the same distance below the folding line that the corresponding vertices are below the folding line in the front elevation. When this is done the edges lf , ly , $l'y$, and $l'f$ may be drawn and the angular elevation is thus completed.

We now have three orthographic projections from which the axial elements and the indices of the faces may be determined graphically, provided we know the unit faces. Let $m = (110)$ and $u = (111)$.

In the plan, the intercept OA of the m face on the a -axis determines the unit a in terms of the intercept OB . The symbol of the l face is $1a:1/2b:\infty c$ or (120) as may be seen by drawing a line parallel to l . This line meets the b -axis at the point T ($OT = 1/2 OB$).

In the angular (110) elevation a line drawn from the point B' parallel to the u (111) face cuts the c -axis at the point C . OC , then, equals the unit c in terms of OB (in the plan). Lines drawn from the point B' parallel to the projection of o and i cut the c -axis at

the points R and P , respectively. As $OR=2 OC$ and $OP=\frac{2}{3} OC$, the symbols of o and i are $1a:1b:2c$ (221) and $1a:1b:\frac{2}{3} c$ (223), respectively.

The symbols of f and y are determined in the front elevation. The unit b and the unit c are transferred from the plan and the (110) elevation. From the point C on the c -axis lines are drawn parallel to the projection of the f and y faces. These intersect the b -axis at the points M and N , respectively. Since $ON=\frac{1}{2} OB$ and $OM=\frac{1}{4} OB$, the symbols of f and y are $\infty a:\frac{1}{2} b:1c$ (021) and $\infty a:\frac{1}{4} b:1c$ (041), respectively. The symbol of the b -face is $\infty a:1b:\infty c$ (010).

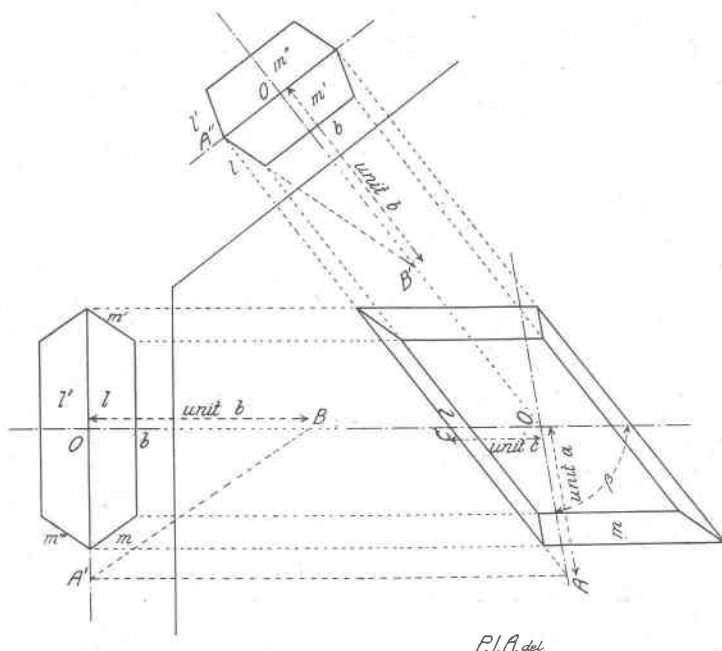

FIGURE 4. PLAN, SIDE ELEVATION, AND SUPPLEMENTARY PROJECTION OF A GYPSUM CRYSTAL.

MONOCLINIC SYSTEM. Gypsum with the forms m (110), b (010), and l (111) is selected as an example of the monoclinic system (Fig. 4). The problem is to determine the axial ratio $a:b:c$ and the angle beta (β).

First, the plan is drawn from the interfacial angles m''' , bm , etc. A convenient distance OB is chosen for the unit length on the

b-axis. The projection of the *a*-axis lies at right angles to that of the *b*-axis but the distance OA' is the foreshortened unit on the *a*-axis.

The side elevation is drawn next and for this purpose it is necessary to measure the angles between the edges mm''' and $l'l'$ by means of a contact goniometer.⁸

In order to complete this elevation a supplementary projection must be used. This is made as shown in the drawing from the interfacial angles bl and $l'l'$. The intersection of dotted lines drawn from the point lmb in the plan and in the supplementary projection furnishes the point lmb in the side elevation. The edges lb and mb are parallel to the edges $l'l'$ and mm''' and thus the side elevation is completed. There is no particular object in making the front elevation for in the monoclinic system there is no zone-axis normal to the front elevation.

It is first necessary to locate the position of the *a*-axis in the side elevation. The edge ml is parallel to the possible face (001), for the three faces (110), (111), and (001) are in the zone $[1\bar{1}0]$. The *a*-axis is parallel to the edge ml , and if OA is drawn from a convenient origin O parallel to the projection of this edge, OA , then, is the unit length of *a* in terms of OB ($=b$) of the plan.

The intersection of a line from A coincident with $l'l'$ determines the point C and since this edge is the projection of a possible (101) face, OC is the unit length of the *c*-axis in terms of OB of the plan.

The acute angle between the *a*- and *c*-axes in the side elevation is the angle beta (β).

TETRAGONAL SYSTEM. For this system a crystal of vesuvianite is chosen. (Fig. 5.) The problem is to determine the axial ratio *a*:*c* and the indices of *t* and *s*; given $p=(111)$, $a=(100)$, $c=(001)$.

The plan is first drawn ($am=45^\circ$; $aa'=90^\circ$); the edge st is parallel to ss^{vii} and pp''' , and pt parallel to mt .

⁸ In order to plot the crystal from interfacial angles alone, recourse may be had to a graphic method based upon the properties of polar triangles as has been suggested by my colleague, Professor L. E. Cutter of the Mechanical Engineering Department. The solution of this is given in Cutter's *Descriptive Geometry* now in press (McGraw-Hill Book Co., New York). But in the opinion of the writer, instead of using polar triangles, it would be preferable to make a stereographic projection. From a stereographic projection a side elevation may easily be constructed.

The angular (110) elevation on the right is made from the interfacial angles cp , pt , and tm . The elevation may be completed from the fact that $s's'''$ is parallel to ts and ps' parallel to as' .

The front elevation may be constructed in either of two ways: (1) by measurement of the angles between the face a' and edge $s's''$,

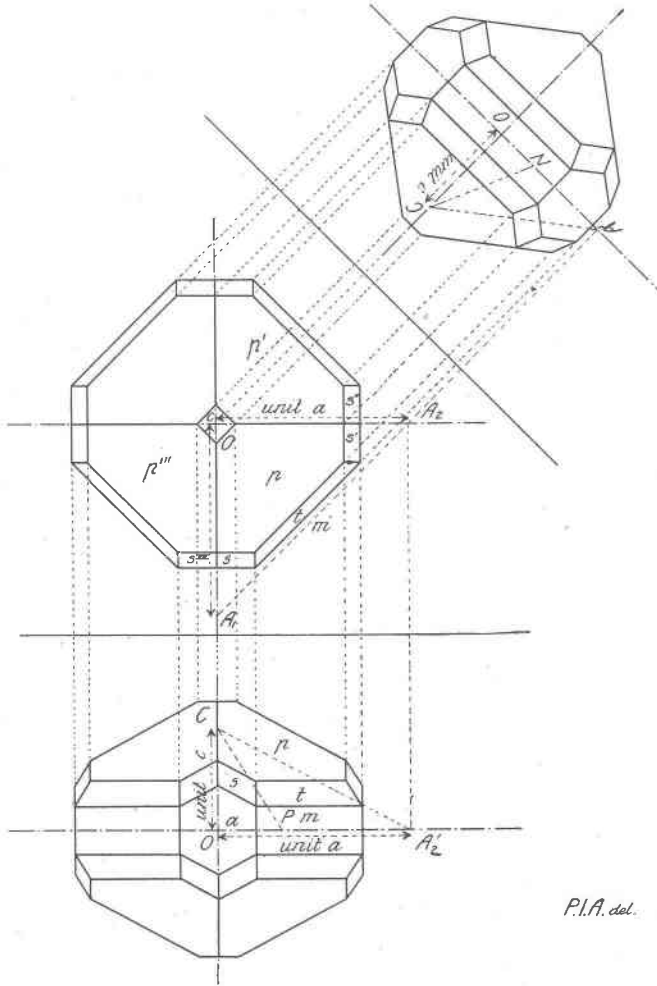

P.I.A. del.

FIGURE 5. PLAN, FRONT ELEVATION AND ANGULAR ELEVATION OF A VESUVIANITE CRYSTAL.

edge $s's''$ and edge pp' , and edge pp' and face c , or (2) by the intersection of vertical lines from the plan with horizontal lines swung around from the angular elevation.

The side elevation is exactly like the front elevation, so it need not be drawn.

The unit c is the distance OC in the angular elevation in terms of OA_1 in the plan. (In the angular elevation this is foreshortened to OA' .)

The symbol of t is $\frac{1}{3}a_1:\frac{1}{3}a_2:1c$ or (331) for $ON = \frac{1}{3}OA'$ in the angular elevation.

Two of the s -faces, $kh\bar{l}$ and $\bar{k}hl$ are in the same zone with a possible $(Ok\bar{l})$ face. A line CP drawn parallel to the edge $s's''$ intersects the a -axis in the point P . Since $OP = \frac{1}{3}OA'_2$, the symbol of the possible $(Ok\bar{l})$ face is $\infty a_1:\frac{1}{3}a_2:1c$ or (031).

The s -face (khl) is also in a zone with p (111), hence the $h:l$ ratio is 1:1 and so the symbol of s' is (131); the one in front is (311), since the ss''' slope is the same as the ss'' slope.

HEXAGONAL SYSTEM. A beryl crystal of tabular habit is taken as an example of the hexagonal system. (Fig. 6.)

The plan is first drawn from the interfacial angles mm' etc. ($=60^\circ$) and from observed zonal relations.

The $(11\bar{2}0)$ elevation on the right is drawn from the interfacial angles cs , etc. There are no complications and the drawing is easily made with the aid of construction lines drawn from the plan.

The other or $(\bar{1}100)$ elevation is made from the cp^v and p^vm^v interfacial angles. The distance of the vertices below the folding line is obtained from the $(11\bar{2}0)$ elevation.

The s -face is chosen as (1121) and hence m is $(10\bar{1}0)$. The lateral axes, then, are drawn as shown in the plan. The line $A''C$ is parallel to the trace of the s -face. The unit length on the c -axis is the distance OC (elevation on the right) in terms of OA_1 in the plan. This must be true, since the symbol of s is $1a_1:1a_2:-\frac{1}{2}a_3:c$.

Since a line drawn parallel to p^v in the $(\bar{1}100)$ elevation intersects the projection of the c -axis and the foreshortened lateral axis OA_1 at unity, the symbol of this face is $(1\bar{1}01)$ and that of p , which has the same slope, is $(10\bar{1}1)$.

ISOMETRIC SYSTEM. For the isometric system a dodecahedral garnet crystal modified by a trapezohedron is selected. (Fig. 7.)

The first figure drawn is the plan, which is constructed from the interfacial angles dd' and the angle between d and the edge nm^{xii} .

The front elevation is next drawn and is exactly like the plan.

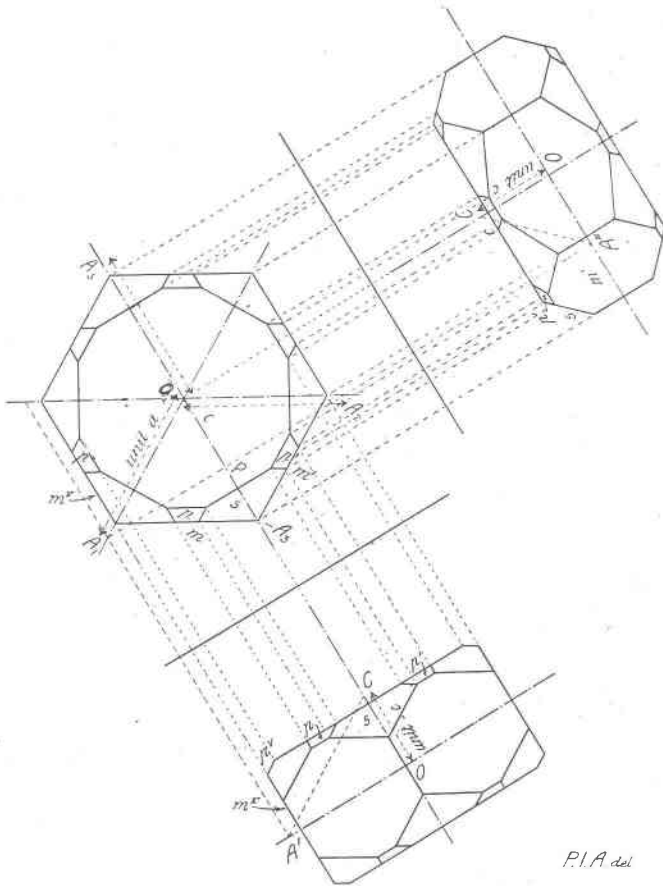

FIGURE 6. PLAN AND ELEVATIONS OF A BERYL CRYSTAL.

The angular (110) elevation is then constructed from the interfacial angles dn'' and $n''n^{viii}$. (It is drawn to the left to save space.) The vertical height of this elevation is the same as that of the front elevation.

The symbol of d is (110); the problem is to determine the symbol of the trapezohedron n , which is of the type (hkk) .

In the plan, a line drawn parallel to the edge $hkk:hk\bar{k}$ from A_2 intersects the a -axis in the point R . Since $OR = \frac{1}{2}OA_1$, the ratio $h:k = 2:1$ and so the symbol of n is (211) .

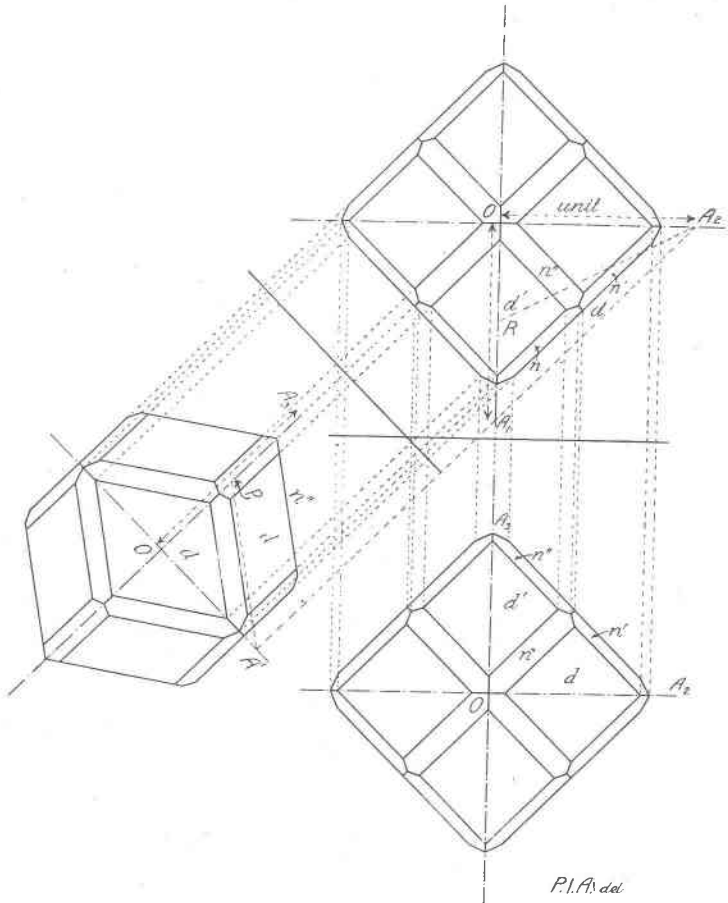

FIGURE 7. PLAN, FRONT ELEVATION, AND ANGULAR ELEVATION OF A GARNET CRYSTAL.

In the (110) elevation, a line drawn from A' parallel to the n'' -face intersects the a -axis in the point P . $OP = \frac{1}{2}OA_3$ and so the ratio $k:h = 1:2$ and $n'' = (112)$.

SUMMARY AND CONCLUSIONS. Plans and elevations of simple crystals usually may be constructed from interfacial angles or from the angles between crystal edges in a comparatively short

time. The third angle projection (in some cases the seventh octant projection) is used and the methods of descriptive geometry are employed. The plans and elevations with an occasional supplementary projection furnish a convenient basis for the application of graphical methods. Miller indices, axial elements, and interfacial angles may be determined graphically and the student may also gain a good general idea of the symmetry and zonal relations of crystals.

PHOSGENITE FROM THE TERRIBLE MINE NEAR ILSE, CUSTER COUNTY, COLORADO

W. A. WALDSCHMIDT, *Colorado School of Mines*

Recently the Colorado School of Mines received two samples of massive cerussite ore representative of the deposit at the Terrible mine near Ilse, Custer County, Colorado. The general appearance of these samples was that of massive crystalline cerussite, white to yellowish white in color, partially covered with a brownish yellow coating, and containing small vugs lined with druses of cerussite crystals. There were also inclusions in the samples which were darker in color and appeared to have different characteristics than the massive cerussite. Blowpipe tests were made on this dark mineral and the reactions obtained indicated immediately that it was not cerussite. Further tests showed the mineral to be the rare chlor-carbonate of lead, phosgenite, ($\text{Pb CO}_3 \cdot \text{Pb Cl}_2$). A preliminary quantitative analysis for lead, made by Professor W. V. Norris of the Department of Chemistry of the Colorado School of Mines, gave 75.3 per cent lead in the dark mineral, whereas the theoretical per cent of lead in phosgenite is 75.97. The color of the phosgenite from the Terrible mine is smoky transparent; luster, vitreous to adamantine; cleavage, perfect in three directions at 90 degrees; fracture, conchoidal; hardness, 2-3; streak, white; fusibility, 1-2; specific gravity (average of six determinations), 6.08. In addition to these physical properties good tests were obtained for lead, carbon dioxide and chlorine.

In preparing this article, in which is included a list of localities where phosgenite has been reported, it was found that the occurrence of phosgenite at the Terrible mine had already been men-