

## MAGNESIOPASCOITE, A NEW MEMBER OF THE PASCOITE GROUP: DESCRIPTION AND CRYSTAL STRUCTURE

ANTHONY R. KAMPF<sup>§</sup>

*Mineral Sciences Department, Natural History Museum of Los Angeles County, 900 Exposition Boulevard,  
 Los Angeles, California 90007, U.S.A.*

IAN M. STEELE

*Department of the Geophysical Sciences, The University of Chicago, 5734 South Ellis Avenue, Chicago, Illinois 60637, U.S.A.*

### ABSTRACT

Magnesiopascoite,  $\text{Ca}_2\text{Mg}(\text{V}_{10}\text{O}_{28}) \cdot 16\text{H}_2\text{O}$ , a new mineral species from the Blue Cap mine, near La Sal, San Juan County, Utah, U.S.A., is named as the Mg analogue of pascoite, Mg occupying one of the two nonequivalent Ca sites in the structure of pascoite. Magnesiopascoite formed from post-mining leaching and oxidation of V–U oxide replacements of organic matter. Magnesiopascoite occurs as parallel stacks of lustrous, transparent, bright-orange crystals that vary in aspect from tabular to equant to prismatic. Numerous small faces in the [110] and  $[\bar{1}\bar{1}0]$  zones (at approximately  $120^\circ$ ) yield shapes and prominent striations that mimic hexagonal symmetry. Crystal intergrowths reach several mm in the largest dimension. The mineral has a yellow streak, an adamantine luster, a Mohs hardness of about  $2\frac{1}{2}$ , and one cleavage, {001} perfect. The measured density is  $2.43(2) \text{ g/cm}^3$ , and the calculated density is  $2.442 \text{ g/cm}^3$ . It is optically biaxial (–),  $\alpha$  1.769(3),  $\beta$  1.802(3),  $\gamma$  1.807(3),  $2V$  (meas.) =  $45(5)^\circ$ ; the dispersion,  $r < v$ , is crossed. The orientation is  $X = b$ ,  $Z \wedge a = 20^\circ$  (in  $\beta$  obtuse), and the pleochroic scheme is Y (orange) > X (yellow), Z (yellow). Electron-microprobe analyses provided: CaO 7.78, MgO 2.67, ZnO 0.23, CoO 0.05,  $\text{V}_2\text{O}_5$  71.32,  $\text{H}_2\text{O}$  21.94 (calc.), total 103.99% which, based on  $V = 10 \text{ apfu}$  with  $O = 44 \text{ apfu}$  and sufficient H for charge balance, yields  $\text{Ca}_{1.77}(\text{Mg}_{0.85}\text{Zn}_{0.04}\text{Co}_{0.01})(\text{H}_2\text{O})_{15.34}(\text{H}_3\text{O})_{0.66}(\text{V}_{10}\text{O}_{28})$ . Magnesiopascoite is monoclinic,  $C2/m$ ,  $a$  19.8442(15),  $b$  9.9353(8),  $c$  10.7149(8) Å,  $\beta$  120.305(1)°,  $V$  1823.9(2) Å<sup>3</sup>,  $Z = 2$ . Its atomic structure [ $R_1 = 2.27\%$  for  $F_o > 4\sigma(F_o)$ ] is similar to that of other pascoite-group minerals. It consists of an anionic decavanadate  $(\text{V}_{10}\text{O}_{28})^{6-}$  structural unit and an interstitial hydrated cationic complex of composition  $\{\text{Ca}_2\text{Mg}(\text{H}_2\text{O})_{16}\}^{6+}$ , which is formed of  $\text{Mg}(\text{H}_2\text{O})_6$  octahedra and seven-coordinated  $\text{CaO}_2(\text{H}_2\text{O})_5$  groups.

*Keywords:* magnesiopascoite, new mineral species, crystal structure, decavanadate, pascoite group, Blue Cap mine, Utah.

### SOMMAIRE

Nous décrivons la magnésiopascoite,  $\text{Ca}_2\text{Mg}(\text{V}_{10}\text{O}_{28}) \cdot 16\text{H}_2\text{O}$ , nouvelle espèce minérale provenant de la mine Blue Cap, près de La Sal, comté de San Juan, au Utah; il s'agit de l'analogue Mg de la pascoïte, le Mg occupant un des deux sites non-équivalents dans la structure de cette dernière. La magnésiopascoïte est apparue suite aux exploitations minières par lessivage et oxydation des oxydes de V et de U formés par remplacement de la matière organique. Elle se présente en empilements parallèles de cristaux transparents brillants de couleur orange et d'aspect tabulaire à équidimensionnel à prismatique. De nombreuses faces dans les zones [110] et  $[\bar{1}\bar{1}0]$  (à environ  $120^\circ$ ) donnent une morphologie et des stries importantes qui rappellent une symétrie hexagonale. Des intercroissances de cristaux atteignent plusieurs mm de diamètre. Le minéral possède une rayure jaune, un éclat adamantin, une dureté de Mohs d'environ  $2\frac{1}{2}$ , et un clivage, {001}, parfait. La densité mesurée est  $2.43(2) \text{ g/cm}^3$ , et la densité calculée est  $2.442 \text{ g/cm}^3$ . La magnésiopascoïte est biaxe (–),  $\alpha$  1.769(3),  $\beta$  1.802(3),  $\gamma$  1.807(3),  $2V$  (mes.) =  $45(5)^\circ$ ; la dispersion,  $r < v$ , est croisée. L'orientation est  $X = b$ ,  $Z \wedge a = 20^\circ$  ( $\beta$  obtus), et le schéma pléochroïque est Y (orange) > X (jaune), Z (jaune). Les analyses effectuées avec une microsonde électronique ont donné: CaO 7.78, MgO 2.67, ZnO 0.23, CoO 0.05,  $\text{V}_2\text{O}_5$  71.32,  $\text{H}_2\text{O}$  21.94 (calc.), pour un total de 103.99%, ce qui a mené à  $\text{Ca}_{1.77}(\text{Mg}_{0.85}\text{Zn}_{0.04}\text{Co}_{0.01})(\text{H}_2\text{O})_{15.34}(\text{H}_3\text{O})_{0.66}(\text{V}_{10}\text{O}_{28})$  en supposant 10 atomes de V et 44 d'oxygène par formule unitaire (apfu), et une quantité suffisante de H pour assurer l'électronéutralité. La magnésiopascoïte est monoclinique,  $C2/m$ ,  $a$  19.8442(15),  $b$  9.9353(8),  $c$  10.7149(8) Å,  $\beta$  120.305(1)°,  $V$  1823.9(2) Å<sup>3</sup>,  $Z = 2$ . Sa structure atomique [ $R_1 = 2.27\%$  pour  $F_o > 4\sigma(F_o)$ ] ressemble à celle des autres membres du groupe de la pascoïte. Elle est faite d'une unité structurale anionique décavanadate  $(\text{V}_{10}\text{O}_{28})^{6-}$  et d'un complexe interstitiel hydraté cationique de composition  $\{\text{Ca}_2\text{Mg}(\text{H}_2\text{O})_{16}\}^{6+}$ , formé d'octaèdres  $\text{Mg}(\text{H}_2\text{O})_6$  et de groupes  $\text{CaO}_2(\text{H}_2\text{O})_5$  à coordinence sept.

(Traduit par la Rédaction)

*Mots-clés:* magnésiopascoïte, nouvelle espèce minérale, structure cristalline, décavanadate, groupe de la pascoïte, mine Blue Cap, Utah.

<sup>§</sup> E-mail address: akampf@nhm.org

## INTRODUCTION

Pascoite,  $\text{Ca}_3(\text{V}_{10}\text{O}_{28}) \cdot 17\text{H}_2\text{O}$ , was first described from the Ragra mine (Minasragra) near Cerro de Pasco, Pasco Department, Peru, by Hillebrand *et al.* (1914), who noted that it formed on the walls of an exploratory tunnel after its excavation. Subsequently, pascoite has been reported from several uranium mining districts in Colorado, Utah, Arizona and New Mexico, as well as from Příbram, Czech Republic and the Urcal deposit, La Rioja, Argentina.

Pascoite contains the decavanadate anionic complex,  $(\text{V}_{10}\text{O}_{28})^{6-}$  (Hughes *et al.* 2005, Swallow *et al.* 1966), as do other members of the pascoite group: hummerite,  $\text{K}_2\text{Mg}_2(\text{V}_{10}\text{O}_{28}) \cdot 16\text{H}_2\text{O}$  (Hughes *et al.* 2002), lasalite,  $\text{Na}_2\text{Mg}_2(\text{V}_{10}\text{O}_{28}) \cdot 20\text{H}_2\text{O}$  (Hughes *et al.* 2008), and perhaps huemulite,  $\text{Na}_4\text{MgV}_{10}\text{O}_{24} \cdot 24\text{H}_2\text{O}$  (Gordillo *et al.* 1966). As has been pointed out by Schindler *et al.* (2000) and others, the structures of these compounds are readily characterized as consisting of the anionic decavanadate structural unit and an interstitial hydrated cationic complex involving alkali or alkaline earth cations (or both).

In this study, we document a new member of the pascoite group, magnesiopascoite,  $\text{Ca}_2\text{Mg}(\text{V}_{10}\text{O}_{28}) \cdot 16\text{H}_2\text{O}$ , which is named as the Mg analogue of pascoite, Mg occupying one of the two nonequivalent Ca sites in the pascoite structure. The new mineral and name have been approved by the Commission on New Minerals, Nomenclature and Classification of the International Mineralogical Association (IMA 2007–025). The two cotype specimens are housed in the mineral collection of the Natural History Museum of Los Angeles County (catalogue numbers 58610 and 58611).

## OCCURRENCE

Magnesiopascoite was discovered by Joe Marty at the Blue Cap mine, about 15 km east of La Sal, San Juan County, Utah, U.S.A. ( $38^\circ 21' 14''\text{N}$ ,  $109^\circ 03' 39''\text{W}$ ), in association with gypsum, rossite, pyrite, montroseite and another new mineral species, martyite (Kampf & Steele 2008) on a V–U oxide-replacement assemblage developed at the expense of organic material. Other minerals identified from the mine are brochantite, calcite, coffinite, corvusite, devilline, dickthomssenite, dolomite, lasalite, montrosite, navajointe, sherwoodite, uraninite, uranopilite and zeunerite. Magnesiopascoite was also identified on a sample collected by Joe Marty at the nearby Vanadium Queen mine.

Uranium–vanadium mineralization in the mines of the area occurs in certain layers of the sandstone paleochannels in the Salt Wash and Brushy Basin members of the Morrison Formation (Carter & Gualtieri 1965). Carbonaceous material in these layers is considered to have created a reducing environment that caused the precipitation of uranium and vanadium oxides (*e.g.*, uraninite, corvusite and montroseite) from solution.

Martyite, magnesiopascoite and rossite appear to have formed from post-mining leaching and oxidation of vanadium oxides by circulating groundwater.

The mode of occurrence and appearance of all pascoite-group minerals (pascoite, hummerite, lasalite and magnesiopascoite) are very similar, making visual identification problematic. It is, therefore, likely that magnesiopascoite exists in other deposits where it has been mistaken for other members of the group.

## PHYSICAL AND OPTICAL PROPERTIES

The mineral forms as parallel stackings of lustrous, transparent, bright-orange crystals that vary in aspect from tabular to equant to prismatic. Complex intergrowths of crystals reach several mm in largest dimension (Fig. 1). The {001} form is prominent, and numerous small faces in the [110] and  $[\bar{1}\bar{1}0]$  zones (at approximately  $120^\circ$ ) yield shapes and prominent striations that mimic a hexagonal symmetry. Forms in these zones include: {302}, {401}, {112}, {113}, {11 $\bar{1}$ }, {1 $\bar{1}\bar{2}$ }, {2 $\bar{2}\bar{3}$ } and {331}. No twinning was observed. We provide a crystal drawing in Figure 2.

The streak is yellow. Crystals are transparent with an adamantine luster. The Mohs hardness is about 2½. The tenacity is brittle, the fracture is conchoidal, and there is one perfect cleavage on {001}. Crystals exhibit curved fractures. The density measured by the sink–float method in sodium polytungstate solution is 2.43(2) g/cm<sup>3</sup>, and that calculated from the empirical formula is 2.442 g/cm<sup>3</sup>. Crystals dissolve slowly in H<sub>2</sub>O and quickly in cold dilute HCl. When mildly heated, magnesiopascoite exhibits rapid decomposition, probably due to dehydration.

The mineral is optically biaxial (–), with the following optical constants measured in sodium light (589 nm):  $\alpha$  1.769(3),  $\beta$  1.802(3),  $\gamma$  1.807(3),  $2V$  (meas.) =  $45(5)^\circ$  and  $2V$  (calc.) =  $42^\circ$ . Dispersion is  $r < v$ , crossed. The pleochroic scheme is:  $Y$  (orange)  $> X$  and  $Z$  (yellow). The optical orientation is  $X = b$ ,  $Z \wedge a = 20^\circ$  (in  $\beta$  obtuse).

The Gladstone–Dale compatibility index  $1 - (K_p/K_c)$ , as defined by Mandarino (1981), provides a measure of the consistency among the average index of refraction, calculated density and chemical composition. For magnesiopascoite, the compatibility index is 0.005, indicating superior agreement among these data.

## CHEMICAL COMPOSITION

Quantitative chemical analyses were performed with an electron microprobe (wavelength-dispersive spectrometry, 15 kV, 25 nA, 5  $\mu\text{m}$  beam diameter). Four analyses gave the following averages (and ranges): CaO 7.78 (7.55–7.99), MgO 2.67 (2.62–2.68), ZnO 0.23 (0.12–0.28), CoO 0.05 (0.01–0.12), V<sub>2</sub>O<sub>5</sub> 71.32 (69.53–73.05), H<sub>2</sub>O 21.94 (calc.), total 103.99%. The amount of H<sub>2</sub>O is calculated from the crystal-structure



FIG. 1. Intergrowth of magnesiopascoite crystals on V-U oxide replacement of organic material. Field of view is 2.2 mm across.

analysis. The high total may be due to rapid loss of H<sub>2</sub>O in the electron beam. When mildly heated, magnesiopascoite exhibits rapid decomposition, probably due to dehydration.

The empirical formula (based on V = 10 atoms per formula unit (*apfu*), with O = 44 *apfu* and sufficient H for charge balance) is Ca<sub>1.77</sub>(Mg<sub>0.85</sub>Zn<sub>0.04</sub>Co<sub>0.01</sub>)(H<sub>2</sub>O)<sub>15.34</sub>(H<sub>3</sub>O)<sub>0.66</sub>(V<sub>10</sub>O<sub>28</sub>). The end-member formula is Ca<sub>2</sub>Mg(V<sub>10</sub>O<sub>28</sub>)•16H<sub>2</sub>O, which requires: MgO 2.98, CaO 8.31, V<sub>2</sub>O<sub>5</sub> 67.35, H<sub>2</sub>O 21.35, total 100.00 wt.%.

#### X-RAY CRYSTALLOGRAPHY AND DETERMINATION OF THE STRUCTURE

X-ray powder-diffraction data (Table 1) were obtained using a Gandolfi camera (114.6 mm diameter,

Ni-filtered CuK $\alpha$  radiation). The data show good agreement with the pattern calculated from the structure.

The collection of diffracted-beam intensities was performed on a Bruker PLATFORM three-circle goniometer equipped with a 1K SMART CCD detector. A full sphere of three-dimensional data was collected. Fifty duplicate frames, acquired at the end of the data collection, indicated that no significant decay had taken place. The measured intensities were corrected for Lorentz and polarization effects using the program SAINT, and an empirical absorption-correction was applied using the program SADABS (Bruker 1997). The SHELXL97 software (Sheldrick 1997) was used for the refinement of the structure.

The positions of atoms other than hydrogen in the pascoite structure were used as a starting point. It was

immediately clear from bond distances involving the Ca1 site at  $(0, \frac{1}{2}, \frac{1}{2})$  and from the isotropic displacement parameter of this site that the site is occupied by Mg in our mineral. We also found that the split O12 (O12A and O12B) and O13 (O13A and O13B) sites in the pascoite structure are not split in magnesiopascoite.

With all non-hydrogen atoms located and refined anisotropically at full occupancies, the  $R_1$  (conventional  $R$  factor) converged to 2.81% for 2061 reflections with  $F_o > 4\sigma(F_o)$ . Results of the chemical analyses suggested that there might be less than full occupancy at the Ca site and less than full occupancy and significant Zn at the Mg site; however, efforts to vary the occupancies of these sites did not improve the refinement significantly.

The difference-Fourier map showed peaks assignable to all likely positions of the H atoms. These positions were refined with O (donor)-H distances restrained to 0.9 Å and the H-H distance corresponding to H<sub>2</sub>O molecules restrained to 1.45 Å, in each case with standard deviations of 0.03. In the final refinement,  $R_1$  converged to 2.27%. Table 2 gives the details of the data collection and structure refinement, Table 3, the final fractional coordinates and displacement parameters, Table 4, selected interatomic distances and angles, Table 5, hydrogen-bond distances and angles, and Table 6, bond valences. Tables of observed and calculated structure-factors are available from the Depository

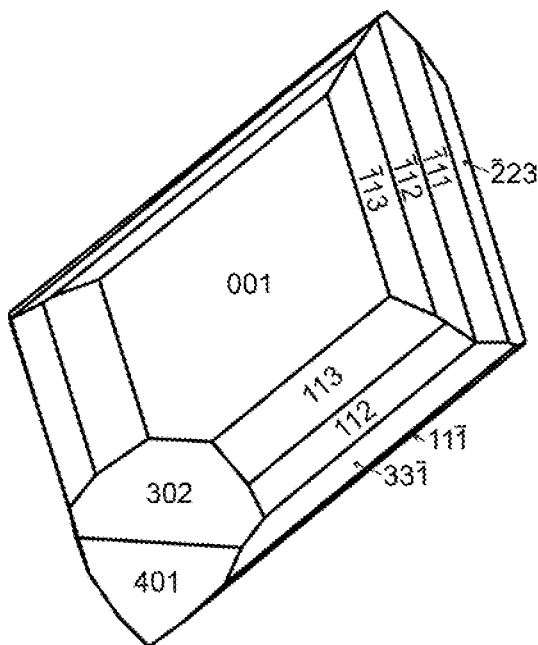

FIG. 2. Drawing of magnesiopascoite crystal.

of Unpublished data on the MAC website [document Magnesiopascoite CM46\_679].

### ATOMIC ARRANGEMENT

The structure of magnesiopascoite (Fig. 3) is similar to those of other pascoite-group minerals. It consists of an anionic decavanadate  $(V_{10}O_{28})^{6-}$  structural unit and an interstitial hydrated cationic complex. The decavanadate structural unit, consisting of ten highly distorted edge-sharing  $V^{5+}O_6$  octahedra, has been described in detail by Schindler *et al.* (2000) and others, and the decavanadate unit specific to the pascoite structure has been described in detail by Hughes *et al.* (2005). Eight of the ten octahedra, V2( $\times 2$ ), V3( $\times 2$ ) and V4( $\times 4$ ) in pascoite and magnesiopascoite are characterized by one short vanadyl bond, four intermediate-length equatorial bonds and one long bond *trans* to the vanadyl bond

TABLE 1. OBSERVED AND CALCULATED X-RAY POWDER-DIFFRACTION PATTERN OF MAGNESIOPASCOITE

$l_{obs}$	$d_{obs}$	$d_{calc}$	$l_{calc}$	$h$	$k$	$l$	$l_{obs}$	$d_{obs}$	$d_{calc}$	$l_{calc}$	$h$	$k$	$l$
20	9.242	9.250	20	0	0	1	10	2.958	2.956	7	$\bar{3}$	3	1
30	8.872	8.917	25	$\bar{2}$	0	1	15	2.813	2.813	9	2	2	2
100	8.571	8.595	88	1	1	0	10	2.741	2.737	5	$\bar{6}$	2	2
40	7.270	7.283	30	$\bar{1}$	1	1	5	2.681	2.684	3	5	1	1
15	5.477	5.474	11	3	1	1	10	2.354	2.353	6	$\bar{1}$	3	3
10	5.130	5.127	9	2	0	1	5	2.197	2.199	4	3	3	2
5	4.973	4.968	3	0	2	0	20	2.137	2.138	6	1	3	3
15	4.590	4.586	11	$\bar{1}$	1	2	20	2.137	2.135	4	9	1	3
15	4.355	4.377	4	0	2	1	5	2.011	2.008	4	2	4	2
10	3.506	3.508	8	4	2	1	10	1.981	1.981	4	$\bar{10}$	0	3
10	3.308	3.318	4	4	2	2	5	1.937	1.934	6	0	4	3
10	3.308	3.318	4	4	2	2	5	1.914	1.914	4	$\bar{10}$	0	4
5	3.278	3.303	2	4	0	1	5	1.773	1.770	3	2	4	3
5	3.278	3.280	4	$\bar{6}$	0	2	10	1.654	1.656	2	0	6	0
									1.650	3	9	3	0

TABLE 2. MAGNESIOPASCOITE: DATA COLLECTION AND STRUCTURE-REFINEMENT DETAILS

Diffractometer	Bruker SMART Platform CCD		
X-radiation / power	MoK $\alpha$ ( $\lambda = 0.71073$ Å) / 50 kV, 45 mA		
Temperature	298(2) K	Space group	C2/m
Unit-cell dimensions	Absorption coefficient		
$a$ (Å)	19.8442(15)	$F(000)$	2.872 mm <sup>-1</sup>
$b$ (Å)	9.9353(8)	Crystal size (a $\times$ b $\times$ c)	1332
$c$ (Å)	10.7149(8)		0.22 $\times$ 0.12 $\times$ 0.05 mm
$\beta$ (°)	120.305(1)	Z	2
$V$ (Å <sup>3</sup> )	1823.9(2)	Index ranges	$-26 \leq h \leq 25$ , $-13 \leq k \leq 13$ , $-14 \leq l \leq 14$
$\theta$ range	3.97 to 28.13°	Reflections collected	8131
		Independent reflections	2334
		Completeness to $\theta$	98.8%
		$= 28.26^\circ$	
Parameters refined	179	Goof <sup>†</sup>	1.097
Refinement method	Full-matrix least-squares on $F^2$		
$R$ indices [ $F_o > 4\sigma(F_o)$ ]	$R_1 = 2.27\%$ , $wR_2 = 6.17\%$		
$R$ indices (all data)	$R_1 = 2.72\%$ , $wR_2 = 6.45\%$		
Largest diff. peak / hole	+0.61 / -0.27 e/Å <sup>3</sup>		

Notes:  $R_{int} = \sum |F_o^2 - F_c^2(\text{mean})| / \sum |F_o^2|$ . <sup>†</sup> Goof =  $S = \sqrt{[\sum (w(F_o^2 - F_c^2))^2] / (n - p)}$ .  
 $R_1 = \sum |F_o| - |F_c| / \sum |F_o|$ .  $wR_2 = \sqrt{[\sum (w(F_o^2 - F_c^2))^2] / \sum (w(F_o^2))^2}$ .  $w = 1 / [\sigma^2(F_o^2) + (aP)^2 + bP]$ , where  $a$  is 0,  $b$  is 12.994 and  $P$  is  $[2F_c^2 + \text{Max}(F_o^2, 0)] / 3$ .

TABLE 3. COORDINATES AND DISPLACEMENT PARAMETERS OF ATOMS IN MAGNESIOPASCOITE

atom	x	y	z	$U_{eq}$	$U_{11}$	$U_{22}$	$U_{33}$	$U_{23}$	$U_{13}$	$U_{12}$
V1	½	0.33296(10)	0	0.0154(2)	0.0169(5)	0.0131(4)	0.0195(5)	0	0.0116(4)	0
V2	0.54298(6)	½	0.79713(11)	0.0164(2)	0.0159(5)	0.0200(5)	0.0165(5)	0	0.0106(4)	0
V3	0.65679(6)	½	0.12750(11)	0.0166(2)	0.0142(5)	0.0210(5)	0.0168(5)	0	0.0095(4)	0
V4	0.38560(4)	0.34654(8)	0.67065(8)	0.0220(2)	0.0208(4)	0.0277(4)	0.0193(4)	-0.0077(3)	0.0114(3)	-0.0049(3)
O1	0.7265(3)	½	0.0902(5)	0.0233(9)	0.0189(21)	0.0305(24)	0.0248(23)	0	0.0142(18)	0
O2	0.5499(2)	½	0.1432(4)	0.0159(8)	0.0159(19)	0.0169(19)	0.0164(19)	0	0.0094(16)	0
O3	0.4160(2)	0.3755(3)	0.0321(3)	0.0159(6)	0.0171(14)	0.0156(13)	0.0187(14)	0.0004(11)	0.0117(11)	-0.0006(11)
O4	0.4498(2)	0.2316(3)	0.8553(3)	0.0214(6)	0.0249(16)	0.0177(14)	0.0254(16)	-0.0033(12)	0.0155(13)	-0.0029(12)
O5	0.6195(3)	½	0.7799(5)	0.0236(9)	0.0216(22)	0.0293(23)	0.0260(23)	0	0.0166(19)	0
O6	0.4828(2)	0.3650(3)	0.6821(3)	0.0209(6)	0.0218(15)	0.0245(15)	0.0205(15)	-0.0052(12)	0.0138(12)	-0.0026(12)
O7	0.6821(2)	0.6352(3)	0.2560(3)	0.0210(6)	0.0181(14)	0.0254(15)	0.0215(15)	-0.0045(12)	0.0115(12)	-0.0046(12)
O8	0.3495(2)	½	0.5634(5)	0.0242(9)	0.0200(21)	0.0353(25)	0.0181(21)	0	0.0101(17)	0
O9	0.3470(2)	0.2276(4)	0.5550(4)	0.0327(8)	0.0299(18)	0.0385(20)	0.0299(18)	-0.0162(16)	0.0152(15)	-0.0089(15)
Mg	0	½	½	0.0198(6)	0.0304(16)	0.0135(13)	0.0182(14)	0	0.0142(12)	0
Ca	0.76667(7)	½	0.91341(14)	0.0214(3)	0.0218(6)	0.0209(6)	0.0262(7)	0	0.0157(5)	0
O10	0.8799(4)	½	0.4285(7)	0.0415(13)	0.0388(31)	0.0368(32)	0.0476(35)	0	0.0209(27)	0
H10	0.870(6)	0.566(7)	0.468(10)	0.1173(390)						
O11	0.9785(4)	½	0.2880(6)	0.0423(14)	0.0569(38)	0.0444(35)	0.0251(28)	0	0.0202(27)	0
H11	0.966(6)	0.568(7)	0.239(9)	0.1169(400)						
O12	0.7190(2)	0.6838(5)	0.7473(5)	0.0433(10)	0.0371(22)	0.0465(24)	0.0366(22)	0.0135(20)	0.0115(18)	-0.0133(19)
H12a	0.748(5)	0.746(7)	0.739(10)	0.0995(324)						
H12b	0.713(5)	0.627(7)	0.683(7)	0.0659(260)						
O13	0	0.7037(5)	½	0.0462(16)	0.0978(51)	0.0178(24)	0.0595(39)	0	0.0667(41)	0
H13	0.001(5)	0.751(7)	0.441(7)	0.0660(245)						
O14	0.8423(2)	0.6719(4)	0.0825(4)	0.0361(9)	0.0496(23)	0.0300(19)	0.0425(22)	-0.0090(17)	0.0331(19)	-0.0164(17)
H14a	0.826(4)	0.700(7)	0.134(7)	0.0463(189)						
H14b	0.866(4)	0.729(6)	0.063(7)	0.0542(212)						
O15	0.8765(4)	½	0.8831(10)	0.0570(20)	0.0666(44)	0.0248(29)	0.1224(64)	0	0.0795(48)	0
H15	0.896(4)	0.564(6)	0.868(8)	0.0637(234)						

TABLE 4. SELECTED BOND-DISTANCES (Å) IN MAGNESIOPASCOITE

V1-		V3-		Mg-	
O4 (× 2)	1.689(3)	O1	1.623(4)	O13 (× 2)	2.023(5)
O3 (× 2)	1.911(3)	O7 (× 2)	1.804(3)	O11 (× 2)	2.090(6)
O2 (× 2)	2.134(3)	O3 (× 2)	2.012(3)	O10 (× 2)	2.104(6)
<V1-O>	1.956	O2	2.210(4)	<Mg-O>	2.072
		<V3-O>	1.968		
V2-		V4-		Ca-	
O5	1.620(4)	O9	1.600(3)	O15	2.361(6)
O6 (× 2)	1.805(3)	O8	1.824(3)	O12 (× 2)	2.387(4)
O3 (× 2)	2.010(3)	O7	1.876(3)	O14 (× 2)	2.389(4)
O2	2.236(4)	O6	1.880(3)	O1	2.397(4)
<V2-O>	1.973	O4	2.073(3)	O5	2.522(4)
		O2	2.316(3)	<Ca-O>	2.412
		<V4-O>	1.994		

(Table 4). The other two octahedra, V1(×2) in pascoite and magnesiopascoite have two short *trans* vanadyl bonds and four intermediate-length equatorial bonds. The marked bond-length variations are consistent with strong electrostatic repulsion between the V<sup>5+</sup> cations. Furthermore, the bond-length variations lead to reasonably well-balanced bond-valences (Table 6).

In magnesiopascoite, the interstitial complex has the composition {Ca<sub>2</sub>Mg(H<sub>2</sub>O)<sub>16</sub>}<sup>6+</sup> and is formed of Mg(H<sub>2</sub>O)<sub>6</sub> octahedra and seven-coordinated CaO<sub>2</sub>(H<sub>2</sub>O)<sub>5</sub> groups (including the two O atoms of the decavanadate

complex, to which the Ca is bonded), whereas in pascoite, the interstitial complex has the composition {Ca<sub>2</sub>Ca(H<sub>2</sub>O)<sub>17</sub>}<sup>6+</sup> and is formed of seven-coordinated Ca(H<sub>2</sub>O)<sub>7</sub> and CaO<sub>2</sub>(H<sub>2</sub>O)<sub>5</sub> groups.

The only significant differences between the structures of magnesiopascoite and pascoite relate to the interstitial complex in each structure, and specifically to the coordinations of the two nonequivalent cation sites that form each complex. In the pascoite structure (Hughes *et al.* 2005, Swallow *et al.* 1966), the interstitial complex has the composition {Ca<sub>2</sub>Ca(H<sub>2</sub>O)<sub>17</sub>}<sup>6+</sup>. The Ca1 site in pascoite at (0,½,½) is effectively coordinated to seven H<sub>2</sub>O molecules, four in fully occupied sites, O10 (×2) and O11 (×2), and three in half occupied sites, O13A (×2) and O13B (×4). In magnesiopascoite, Mg is located at (0,½,½) and is coordinated to six H<sub>2</sub>O molecules, all in fully occupied sites, O10 (×2), O11 (×2) and O13 (×2), forming a nearly perfect octahedron. In both cases, the cations bond only to H<sub>2</sub>O molecules, which in turn link to O atoms of the decavanadate complex and the other portion of the interstitial complex only *via* H bonding.

The coordinations surrounding the other cation site, Ca2 in pascoite and Ca in magnesiopascoite, are both seven-fold and differ only in that one pair of ligated O sites (O12) is split in pascoite, but not in magnesiopas-

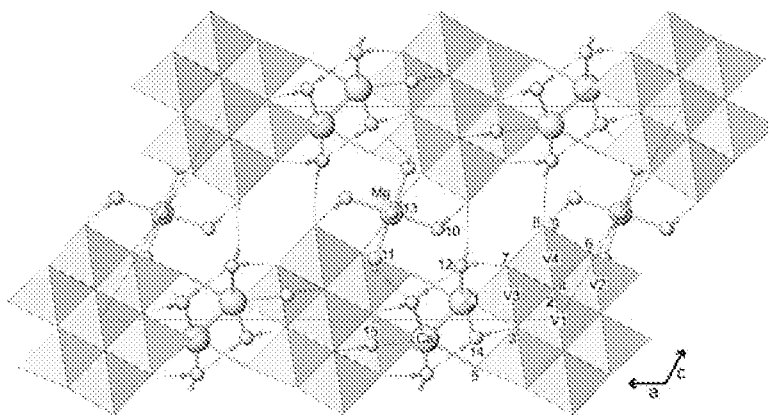

FIG. 3. Crystal structure of magnesiopascoite viewed down the *b* axis. The numbers refer to O atoms. H bonds are shown with dotted lines.

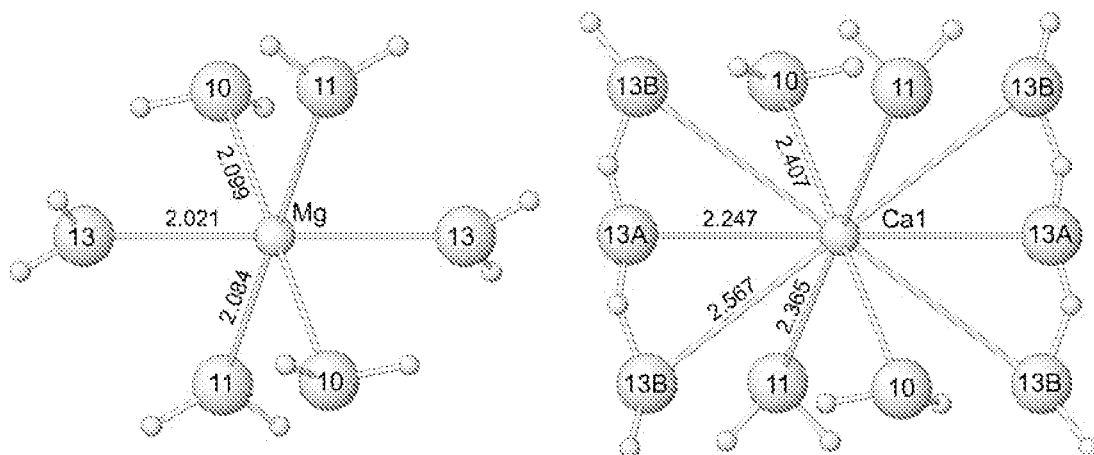

FIG. 4. Coordination around Mg in magnesiopascoite (left) and Ca1 in pascoite (right).

TABLE 5. HYDROGEN-BOND DISTANCES (Å) AND ANGLES (°) IN MAGNESIOPASCOITE

D-H	<i>d</i> (D-H)	<i>d</i> (H-A)	∠D-H-A	<i>d</i> (D-A)	A	∠H-D-H
O10-H10 (× 2)	0.85(6)	2.02(6)	178(10)	2.875(5)	O9	100
O11-H11 (× 2)	0.82(6)	2.39(8)	133(9)	3.011(7)	O14	112
O12-H12A	0.88(6)	1.80(6)	172(10)	2.676(5)	O7	101
O12-H12B	0.86(5)	2.63(8)	103(6)	2.951(5)	O9	
O13-H13 (× 2)	0.79(5)	1.89(5)	173(8)	2.676(4)	O6	107
O14-H14A	0.82(5)	2.21(5)	168(6)	3.017(7)	O12	113
O14-H14B	0.82(5)	1.89(5)	173(7)	2.706(5)	O3	
O15-H15 (× 2)	0.80(5)	2.02(5)	173(7)	2.817(4)	O4	105

D = donor O; A = acceptor O.

coite. In both cases, Ca bonds to two O atoms, O1 and O5, of the decavanadate complex and to five H<sub>2</sub>O molecules, O12 (×2), O14 (×2) and O15. The coordinations of the cation sites of the interstitial complexes in magnesiopascoite and pascoite are compared in Figures 4 and 5.

#### ACKNOWLEDGEMENTS

We particularly thank Joe Marty for providing the specimens used in this study as well as for information regarding their occurrence. We thank Saeed Khan for

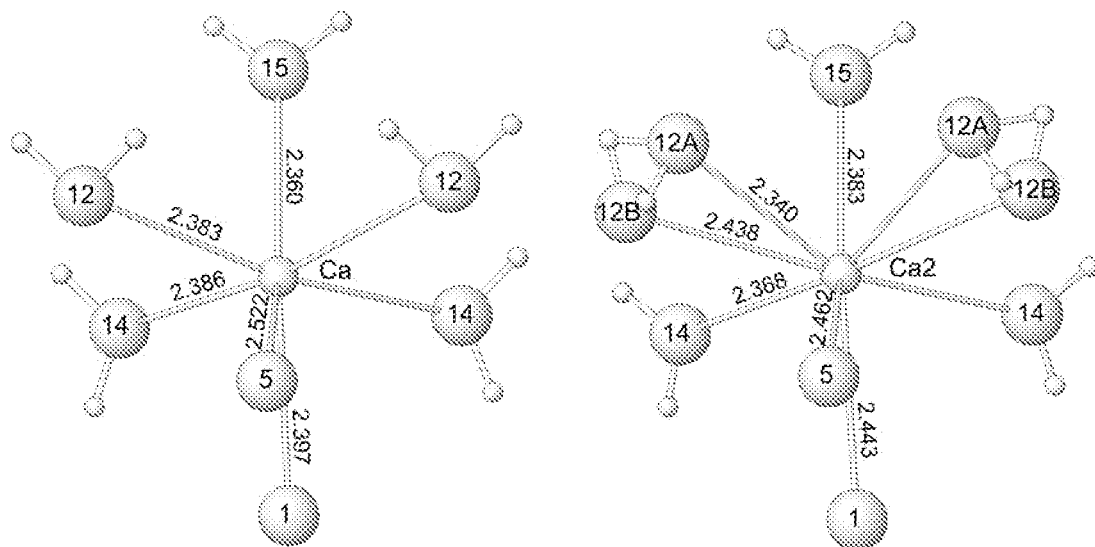

FIG. 5. Coordination around Ca in magnesiopascoite (left) and Ca<sub>2</sub> in pascoite (right).

TABLE 6. BOND-VALENCE SUMMATIONS FOR MAGNESIOPASCOITE

	O1	O2	O3	O4	O5	O6	O7	O8	O9	O10	O11	O12	O13	O14	O15	Σ <sub>cv</sub>
V1		0.409	0.747	1.361												5.034
V2		0.310	0.572		1.640	0.995										5.084
V3	1.627	0.333	0.568				0.997									5.090
V4		0.250		0.483		0.812	0.821	0.945	1.731							5.042
Mg										0.329	0.342		0.410			2.162
Ca	0.313				0.223							0.321		0.320	0.346	2.164
H10								0.160	1.680							1.000
H11											1.744			0.128		1.000
H12A							0.239					0.761				1.000
H12B									0.140			0.860				1.000
H13						0.239							1.522			1.000
H14A												0.127		0.873		1.000
H14B			0.224											0.776		1.000
H15				0.178											1.644	1.000
Σ <sub>av</sub>	1.939	1.961	2.111	2.022	1.863	2.046	2.057	1.890	2.031	2.009	2.086	2.069	1.932	2.097	1.990	

Non-hydrogen bond-strengths from Brese & O'Keeffe (1991); hydrogen bond-strengths from Ferraris & Ivaldi (1988), based on O–O distances; valence summations are expressed in valence units.

his assistance with the collection of structure data in the X-Ray Crystallography Laboratory of the University of California, Los Angeles, Department of Chemistry and Biochemistry. We acknowledge Michael Schindler and John M. Hughes for their helpful reviews of the manuscript and Robert F. Martin for suggestions on improving the manuscript. This study was funded by the John Jago Trelawney Endowment to the Mineral Sciences Department of the Natural History Museum of Los Angeles County.

## REFERENCES

- BRESE, N.E. & O'KEEFE, M. (1991): Bond-valence parameters for solids. *Acta Crystallogr.* **B47**, 192-197.
- BRUKER (1997): SADABS, SAINT, SMART and SHELXTL. Bruker AXS Inc., Madison, Wisconsin.
- CARTER, W.D. & GUALTIERI, J.L. (1965): Geology and uranium–vanadium deposits of the La Sal Quadrangle, San Juan County, Utah, and Montrose County, Colorado. *U.S. Geol. Surv., Prof. Pap.* **508**.
- FERRARIS, G. & IVALDI, G. (1988): Bond valence vs. bond length in O...O hydrogen bonds. *Acta Crystallogr.* **B44**, 341-344.
- GORDILLO, C.E., LINARES, E., TOUBES, R.O. & WINCHELL, H. (1966): Huemulite,  $\text{Na}_4\text{MgV}_{10}\text{O}_{24}\cdot 24\text{H}_2\text{O}$ , a new hydrous sodium and magnesium vanadate – from Huemul mine, Mendoza Province, Argentina. *Am. Mineral.* **51**, 1-13.
- HILLEBRAND, W.F., MERWIN, H.E. & WRIGHT, F.E. (1914): Hewettite, metaheuwettite and pascoite, hydrous calcium vanadates. *Proc. Am. Philosoph. Soc.* **53**, 31-54.
- HUGHES, J.M., SCHINDLER, M. & FRANCIS, C.A. (2005): The  $C2/m$  disordered structure of pascoite,  $\text{Ca}_3[\text{V}_{10}\text{O}_{28}]\cdot 17\text{H}_2\text{O}$ : bonding between structural units and interstitial complexes in compounds containing the  $[\text{V}_{10}\text{O}_{28}]^{6-}$  decavanadate polyanion. *Can. Mineral.* **43**, 1379-1386.
- HUGHES, J.M., SCHINDLER, M., RAKOVAN, J. & CURETON, F. (2002): The crystal structure of hummerite,  $\text{KMg}(\text{V}_5\text{O}_{14})\cdot 8\text{H}_2\text{O}$ : bonding between the  $[\text{V}_{10}\text{O}_{28}]^{6-}$  structural unit and the  $\{\text{K}_2\text{Mg}_2(\text{H}_2\text{O})_{16}\}^{6+}$  interstitial complex. *Can. Mineral.* **40**, 1429-1435.
- HUGHES, J.M., WISE, W.S., GUNTER, M.E., MORTON, J.P. & RAKOVAN, J. (2008): Lasalite,  $\text{Na}_2\text{Mg}_2(\text{V}_{10}\text{O}_{28})\cdot 20\text{H}_2\text{O}$ , a new decavanadate mineral from the Vanadium Queen mine, La Sal district, Utah: mineral description, atomic arrangement, and relationship to the pascoite group of minerals. *Can. Mineral.* (in press).
- KAMPF, A.R. & STEELE, I.M. (2008): Martyite, a new mineral species related to volborthite: description and crystal structure. *Can. Mineral.* **46**.
- MANDARINO, J.A. (1981): The Gladstone–Dale relationship. IV. The compatibility concept and its application. *Can. Mineral.* **19**, 441-450.
- SCHINDLER, M., HAWTHORNE, F.C. & BAUR, W.H. (2000): A crystal-chemical approach to the composition and occurrence of vanadium minerals. *Can. Mineral.* **38**, 1443-1456.
- SHELDRIK, G.M. (1997): SHELXL97. *Program for the Refinement of Crystal Structures*. University of Göttingen, Göttingen, Germany.
- SWALLOW, A.G., AHMED, F.R. & BARNES, W.H. (1966): The crystal structure of pascoite,  $\text{Ca}_3\text{V}_{10}\text{O}_{28}\cdot 17\text{H}_2\text{O}$ . *Acta Crystallogr.* **21**, 397-405.

Received January 4, 2008, revised manuscript accepted May 17, 2008.