

NEW MINERALS APPROVED BY THE IMA COMMISSION ON NEW MINERALS AND MINERAL NAMES

ALLABOGDANITE, $(\text{Fe,Ni})_2\text{P}$

Allabogdanite, a mineral dimorphous with barringerite, was discovered in the Onello iron meteorite (Ni-rich ataxite) found in 1997 in the alluvium of the Bol'shoy Dolguchan River, a tributary of the Onello River, Aldan River basin, South Yakutia (Republic of Sakha-Yakutia), Russia. The mineral occurs as light straw-yellow, with strong metallic luster, lamellar crystals up to 0.01 x 0.1 x 0.4 mm, typically twinned, in plessite. Associated minerals are nickelposphide, schreibersite, awaruite and graphite (Britvin *e.a.*, 2002b).

Name: in honour of Alla Nikolaevna BOGDANOVA (1947–2004), Russian crystallographer, for her contribution to the study of new minerals; Geological Institute of Kola Science Center of Russian Academy of Sciences, Apatity.

IMA No.: 2000-038. *TS:* PU 1/18632.

ALLOCHALCOSELITE, $\text{Cu}^+\text{Cu}_5^{2+}\text{PbO}_2(\text{SeO}_3)_2\text{Cl}_5$

Allochalcoseelite was found in the fumarole products of the Second cinder cone, Northern Breakthrough of the Tolbachik Main Fracture Eruption (1975–1976), Tolbachik Volcano, Kamchatka, Russia. It occurs as transparent dark brown prismatic crystals up to 0.1 mm long. Associated minerals are cotunnite, sofiite, ilinskite, georgbokiite and burnsite (Vergasova *e.a.*, 2005).

Name: for the chemical composition: presence of *se*lenuium and different oxidation states of copper, from the Greek $\alpha\lambda\lambda\omicron\varsigma$ (different) and $\chi\alpha\lambda\kappa\omicron\varsigma$ (copper).

IMA No.: 2004-025. *TS:* no reliable information.

ALSAKHAROVITE-Zn, $\text{NaSrKZn}(\text{Ti,Nb})_4[\text{Si}_4\text{O}_{12}]_2(0,\text{OH})_4\cdot 7\text{H}_2\text{O}$ photo 1

Labuntsovite group

Alsakharovite-Zn was discovered in the Pegmatite #45, Lepkhe-Nel'm Mt., Lovozero massif, Kola Peninsula, Russia. It occurs as white, pale brown or colourless coarse flattened-prismatic crystals up to 0.5 x 2 x 8 mm in cavities. Associated minerals are lamprophyllite, natrolite, kuzmenkoite-Zn, tsepinite-Na, vinogradovite, halloysite, rancieite *etc.* (Pekov *e.a.*, 2003f).

Name: in the memory of *Aleksey Sergeevich SAKHAROV* (1910–1996). Russian petrologist and geologist actively studied Lovozero alkaline massif and its rare-metal deposits; Geological Institute of Kola Branch of USSR Academy of Sciences, Apatity. Suffix-modifier -Zn reflects prevailing of Zn in the *D* site of the structure (Chukanov *e.a.*, 2002b).

IMA No.: 2002-003. *TS:* FMM 91047.

ALUMINO-MAGNESIOHULSITE, $\text{Mg}_2(\text{Al}_{1-2x}\text{Mg}_x\text{Sn}_x)(\text{BO}_3)_2\text{O}_2$

Alumino-magnesiohulsite was discovered in a single thin section of a boron ore from unnamed locality near the mouth of Kebirin'ya creek, a northern (right) tributary of Dogdo River, Yana River basin, Tas-Khayakhtakh Ridge in the Chersky

Mountain System, Eastern Verkhoyan'e, Polar Yakutia (Republic of Sakha-Yakutia), Siberia, Russia. The specimen was found by N.N. Pertsev in 1964. The mineral occurs as euhedral stout prisms up to 0.09 mm in a kotoite marble. Under the microscope, in transmitted light, it shows pleochroism from brown to blue-green. Associated minerals are calcite, kotoite, forsterite, clinohumite, spinel, ludwigite, pertsevite, lollingite, szaibelyite and brucite (Pertsev *e.a.*, 2004).

Name: Al-dominant analogue of magnesiohulsite.

IMA No.: 2002-038. *TS:* Mineralogical Collection of Institut für Geologie, Mineralogie und Geophysik, Ruhr-Universität Bochum, Germany: 25164; FMM 91903.

ANKINOVICHITE, $(\text{Ni,Zn})\text{Al}_4(\text{VO}_3)_2(\text{OH})_{12}\cdot 2\text{H}_2\text{O}$ photo 2

Ankinovichite, a Ni-dominant analogue of alvanite, was first described from two localities. Initially it was found at the Kurumsak vanadium deposit, 15 km south-east of Aksumbe village, North-Western Karatau Range, Chimkent (Shymkent) District, South Kazakhstan. Some later, specimens with the same mineral were collected at the Kara-Chagyr U-Ni-V occurrence, right bank of Isfairamsai River valley, Fergana Valley, Osh District, Kyrgyzstan. Both places are considered as equal type localities. At Kurumsak, ankinovichite occurs in cavities of a V-bearing carbonaceous clay shale. It forms crusts of pale green (with lettuce tint) prismatic crystals up to 0.5 mm long overgrowing alvanite spherulites; other associated minerals are volborthite, carnotite and goethite. At Kara-Chagyr, ankinovichite occurs as pale green to light blue elongate tabular crystals up to 0.2 mm, typically twinned and split, and their brushes in cracks of a brecciated siliceous rock. Associated minerals are kolovratite, volborthite, nickelalumite, metatuyamunite, roscoelite, allophane and tangeite (Karpenko *e.a.*, 2004).

Name: in the memory of Ekaterina Aleksandrovna ANKINOVICH (1911–1991), well-known mineralogist, a specialist in the mineralogy and geology of vanadium-bearing formation of Central Asia, discoverer of 11 new minerals, and her husband Stepan Gerasimovich ANKINOVICH (1912–1985), a geologist who studied the geology of Karatau Range and some other regions of former USSR; both they worked in Kazakh Polytechnical Institute, Alma-Ata: E.A. Ankinovich – in Department of Mineralogy, S.G. Ankinovich – in Department of Petrography.

IMA No.: 2002-063. *TS:* FMM 91660.

AQUALITE, $(\text{H}_3\text{O})_8(\text{Na,K,Sr})_5\text{Ca}_6\text{Zr}_3\text{Si}_{26}\text{O}_{66}(\text{OH})_9\text{Cl}$ photo 3 *Eudialyte group*

Aqualite was discovered in specimens from the Inagli massif, 30 km northwest of the city of Aldan, South Yakutia (Republic of Sakha-Yakutia), Russia. It occurs as pink grains up to 5 mm in a peralkaline pegmatite, with microcline, natrolite, aegirine, lorenzenite, innelite, batisite, thorite and galena (Khomyakov, in press[a]). Earlier it was mentioned from the same locality as "hydrated eudialyte" (Efimov *e.a.*, 1963).

Name: from the Latin *aqua* (water) that reflects very strong hydration, unusual for eudialyte group minerals.

IMA No.: 2002-066. *TS:* FMM 92099.

ARAPOVITE, $(\text{U,Th})(\text{Ca,Na})_2(\text{K}_{1-x}\square_x)\text{Si}_8\text{O}_{20}\cdot \text{H}_2\text{O}$ *Steacyite group*

Arapovite, an U-dominant analogue of turkestanite, was found in the moraine of the Darai-Pioz Glacier, southern slope of the Alai Range, Tadjikistan. It occurs in an alkaline pegmatite-like rock which consists mainly of microcline, aegirine, polyolithionite, with stillwellite-(Ce), turkestanite, sogdianite, zektzerite, pyrochlore, hyalotekite, tadjikite,

albite and quartz. Arapovite forms areas (up to 0.3 mm) in crystals (up to 1 cm) of turkestanite. The mineral is dark green unlike turkestanite which is typically light green (Agakhanov *e.a.*, 2004).

Name: in the memory of Yuriy Aleksandrovich ARAPOV (1907–1988), Russian geologist, the author of numerous works on the geochemistry, mineralogy and petrology of Turkestan–Alai region of Central Asia, who studied, in particular, Darai-Pioz alkaline massif and found "green thorium silicate"; Pamirs–Tadjik Geological Expedition, Dushanbe.

IMA No.: 2003-046. *TS:* FMM 91645.

AVDONINITE, $K_2Cu_5Cl_8(OH)_4 \cdot H_2O$

Avdoninite was described as a new mineral species from the exhalation products of the Yadovitaya (Poisonous) Fumarole, the Second cinder cone, Northern Breakthrough of the Tolbachik Main Fracture Eruption (1975–1976), Tolbachik Volcano, Kamchatka, Russia (Chukanov *e.a.*, 2006a). Earlier the same mineral with the name avdoninite and the formula $K_2Cu_5Cl_8(OH)_4$ was described from contemporary oxidized zone at two operating copper mines at the Urals, Russia: on old dumps of the mine at the Degtyarka deposit, Sverdlovsk District, (found by T.V. Avdonina) and at the open pit of the Blyava Mine, Orenburg District (found by V.G. Korinevskii). This material was considered as "semi-technogene" and the mineral was not submitted to the IMA CNMMN. However the authors of its description supposed that the same mineral can be found in volcanic exhalations like other K,Cu-oxychlorides (Bushmakin, Bazhenova, 1998). This prediction soon became realized: identical mineral was found by M.N. Murashko at Tolbachik Volcano. Thus, the mineral has been studied on undoubtedly natural material, a fumarole product, which is considered as the holotype. The authors of this work preserved the name avdoninite. At Tolbachik, the mineral together with paratacamite, belloite or atacamite form pseudomorphs after water-free copper minerals, mainly after euchlorine and melanothallite. Avdoninite occurs as bright lettuce-green coarse short-prismatic and tabular crystals up to 0.2 mm which usually form crusts (Chukanov *e.a.*, 2006a). At Degtyarka, avdoninite forms bright green massive roundish aggregates up to 15 cm across on the surface of a dump. At Blyava, avdoninite, mitscherlichite, atacamite and nantokite were found in a pseudomorph after unidentified steel(?) thing (4.5 x 7 x 11 cm) formed in a pool in operating open pit (Bushmakin, Bazhenova, 1998).

Name: in honour of Vladimir Nikolaevich AVDONIN (b. 1925), Russian mineralogist, a specialist in the mineralogy of the Urals, who studied supergene minerals at operating copper deposits; Urals Geological Museum, Ekaterinburg.

IMA No.: 2005-046. *TS:* PU 19175 (Tolbachik); IR and Urals Geological Museum, Ekaterinburg (specimens from the Urals).

AVERIEVITE, $Cu_5O_2(VO_4)_2 \cdot n(Cs,Rb,K)Cl$

Averievite was found in the fumarole products of the Second cinder cone, Northern Breakthrough of the Tolbachik Main Fracture Eruption (1975–1976), Tolbachik Volcano, Kamchatka, Russia. It occurs as black hexagonal lamellar crystals up to 0.1 x 0.3 mm, with resinous to metallic luster. Associated minerals are alumoklyuchevskite, langbeinite, piypite, tenorite *etc.* (Vergasova *e.a.*, 1998b).

Name: after Valerii Viktorovich AVER'EV (1929–1968), Russian volcanologist, a specialist in the geothermy of volcanic regions; Institute of Volcanology, Petropavlovsk-Kamchatskii.

IMA No.: 95-027. *TS:* PMM 2102/1.

BAKHCHISARAITSEVITE, $Na_2Mg_5(PO_4)_4 \cdot H_2O$

photo 4

Bakhchisaraitsevite was discovered at the open pit of the Iron Mine, Kovdor massif, Kola Peninsula, Russia. It occurs in cavities in dolomite carbonatites, with bobierrite, pyrite, collinsite, nastrophite, juonniite and chlorite. Bakhchisaraitsevite forms colourless, yellow or greenish tabular to lamellar crystals up to 0.5 x 1.5 x 2 mm and fan-shaped aggregates (Liferovich *e.a.*, 2000a).

Name: in the memory of Aleksandr Yur'evich BAKHCHISARAITSEV (1947–1998), Russian crystallographer who studied Kola minerals for 30 years and became co-author in descriptions of eight new minerals; Geological Institute of Kola Science Center of Russian Academy of Sciences, Apatity.

IMA No.: 99-005. *TS:* KSC 6141.

BARIO-OLGITE, $Ba(Na,Sr,REE)_2Na(PO_4)_2$

photo 5

Bario-olgitite was described as a new mineral species from the Palitra pegmatite, Kedykverpakhk Mt., Lovozero massif, Kola Peninsula, Russia. It occurs as light green grains up to 1 x 1.5 cm, rarely pyramidal-prismatic crystals up to 5 mm similar to quartz crystals in morphology. Bario-olgitite fluoresces bright pinkish-orange in shortwave ultraviolet light and weak pink-red in longwave ultraviolet light. Associated minerals in the core of a peralkaline pegmatite are manaksite, natrosilite, villiamite, aegirine, ussingite, sodalite, serandite, chkalovite, vuonnemite, sphalerite *etc.* (Pekov *e.a.*, 2004a). Newly obtained data

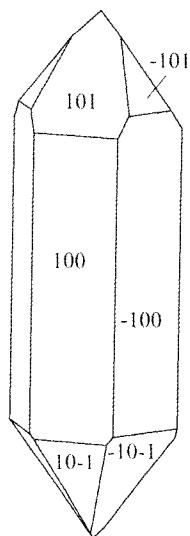

Bario-oligite crystal (Pekov *e.a.*, 2004a).

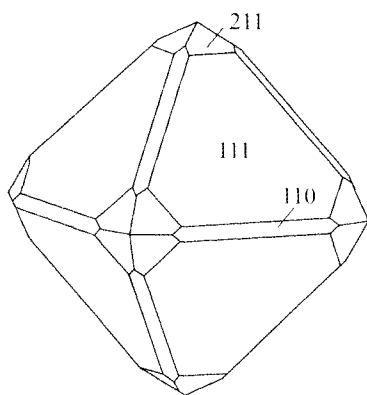

Bismutopyrochlore crystal (Chukanov *e.a.*, 1999d).

(Sokolova *e.a.*, 2005) show that some samples earlier considered as oligite are identical to bario-oligite in idealized formula. It was supposed that original oligite was studied incorrectly and it is identical to bario-oligite in its idealized formula and symmetry, and it was proposed to discredit bario-oligite (Sokolova *e.a.*, 2005). A proposal to discredit bario-oligite was submitted to the IMA CNMMN, discussed with participation of the Commission members and, in result, withdrawn in June 2006.

Name: Ba-dominant analogue of oligite.

IMA No.: 2003-002. *TS:* FMM 91376.

BIRAITE-(Ce), $Ce_2Fe^{2+}(CO_3)(Si_2O_7)$

Biraite-(Ce) was discovered at the Biraia *REE* deposit, basin of Biraia River, 150 km east of the city of Bodaibo, Irkutsk District, Siberia, Russia. It occurs in a carbonatite vein (6–7 cm thick) among fenites. Biraite-(Ce) forms brown irregular grains and crystals up to 3 mm, sometimes partially replaced by hydroxylbastnasite-(Ce). Associated minerals are dolomite, cordylite-(Ce), aragonite, strontianite, ancylite-(Ce), ancylite-(La), daqingshanite-(Ce), tremolite, winchite, ferriallanite-(Ce), tornebohmite-(Ce), cerite-(Ce), chevkinite-(Ce), belkovite, humite, fergusonite-(Ce), fergusonite-(Nd), pyrochlore, barite, monazite-(Ce) *etc.* (Konev *e.a.*, 2005).

Name: for the type locality.

IMA No.: 2003-037. *TS:* FMM 91375.

BISMUTOPYROCHLORE, $(Bi,U,Ca,Pb)_{1+x}(Nb,Ta)_2O_6(OH) \cdot nH_2O$

photo 6

Pyrochlore group

Bismutopyrochlore was discovered in the Mika pegmatite vein, Tau Mt., Turakuloma Range, Rangkul' Uppland, Eastern Pamirs, Tadjikistan. It occurs as greenish-brown and black octahedral crystals (usually with subordinate forms {110} and {211}) up to 1 cm or forms zones in crystals mainly consisting of Bi-bearing pyrochlore and/or uranpyrochlore. Pyrochlore-group minerals were found in the axial zone of this granitic pegmatite vein with lepidolite, microcline, quartz, elbaite, topaz, beryl, fluorapatite, barite *etc.* Some crystals of pyrochlores from Mika contain inclusions of native bismuth and ustarasite (Chukanov *e.a.*, 1999d).

Name: Bi-dominant analogue of pyrochlore.

IMA No.: 98-059. *TS:* FMM 85903.

BOROCOOKEITE, $Li_{1+3x}Al_{4-x}[BSi_3O_{10}](OH)_8 \cdot x = 0-0.33$

Chlorite group

Borocookeite was discovered in the Sosedka (the holotype) and Mokhovaya pegmatite veins, Malkhan pegmatite field, south slope of Malkhan Ridge, Krasnyi Chikoy area, Central Transbaikal Region, Chita District, Siberia, Russia. It was found in miaroles in granitic pegmatites containing gem colour tourmaline. Borocookeite forms light gray, with a pinkish or yellow hue, massive crypto-flaky aggregates up to 5 cm, crusts up to 2 mm thick and snow-like coatings on crystals of quartz, feldspar and elbaite. Other associated minerals are lepidolite, dandurite, B-rich muscovite and laumontite (Zagorsky *e.a.*, 2003).

Name: B-dominant analogue of cookeite.

IMA No.: 2000-013. *TS:* FMM 91289.

BRADACZEKITE, $NaCu_4(AsO_4)_3$

Alluaudite group

Bradaczekite was discovered in the fumarole products of the Second cinder cone, Northern Breakthrough of the Tolbachik Main Fracture Eruption (1975–1976),

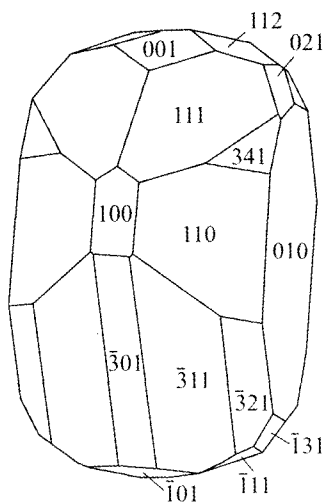

Bradaczekite crystal (Filatov *e.a.*, 2001).

Tolbachik Volcano, Kamchatka, Russia. It occurs as aggregates of dark blue well-shaped platy crystals up to 0.2 mm. Associated minerals are hematite, tenorite, lammerite, johillerite, urusovite and orthoclase (Filatov *e.a.*, 2001).

Name: in honour of Hans BRADACZEK (b. 1940), German crystallographer; Free University of Berlin.

IMA No.: 2000-002. *TS:* FMM 90049.

BURNSITE, $\text{KCdCu}_7\text{O}_2(\text{SeO}_3)_2\text{Cl}_9$

Burnsite was discovered in the fumarole products of the Second cinder cone, Northern Breakthrough of the Tolbachik Main Fracture Eruption (1975–1976), Tolbachik Volcano, Kamchatka, Russia. It occurs as dark red, with strong metalloid luster, grains up to 0.1 mm long, visually similar to georgbokiite. Associated minerals are cotunnite, sofiite, ilinskite, georgbokiite and chloromenite (Krivovichev *e.a.*, 2002).

Name: in honour of Peter Carman BURNS (b. 1966), Canadian-born mineralogist and structural crystallographer, in recognition of his important contributions to structural mineralogy and, in particular, to knowledge about the structures of Cu^{2+} oxysalt minerals; University of Notre Dame, Notre Dame, Indiana, U.S.A.

IMA No.: 2000-050. *TS:* FMM 90283.

BURYATITE, $\text{Ca}_3(\text{Si,Fe}^{3+},\text{Al})[\text{SO}_4][\text{B}(\text{OH})_4](\text{OH})_5 \cdot 0.12\text{H}_2\text{O}$ *Etringite group*

Buryatite was discovered in the core of a borehole (depth 184 m) at the Solongo Fe-B deposit, Buryatia, Siberia, Russia. It occurs as lenticular nests up to 3 x 10 mm with subordinate calcite and sometimes magnetite, brucite and fluorborite. They are found in close association with frolovite veinlets cross-cutting kurchatovite-sakhaite rock. Other associated minerals are vimsite, solongoite, pentahydroborite, hexahydroborite (in veinlets), fedorovskite, ludwigite, turneurite, sphalerite and calcite (in rock). Buryatite forms aggregates of coarse hexagonal prismatic crystals (up to 0.01 mm) and fine-grained mass. The mineral is light-gray with lilac tint. It weakly fluoresces bluish in shortwave ultraviolet light (Malinko *e.a.*, 2001).

Name: after the locality in Buryatia Autonomous Republic.

IMA No.: 2000-021. *TS:* FMM 90283.

Crystals of **buryatite**. Solongo, Buryatia, Siberia, Russia. SEM image. Magnification: 9000x. Specimen and photo: S.V. Malinko.

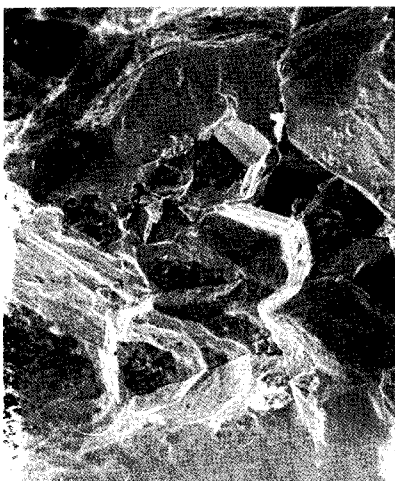

BUSHMAKINITE, $\text{Pb}_2\text{Al}(\text{PO}_4)(\text{VO}_4)(\text{OH})$ *Brackebuschite group*

Bushmakinite was discovered in a specimen from one of upper levels of the Severnaya (North) underground mine, Berezovskoye gold deposit, Middle Urals, Russia. This specimen was collected in 1943 and deposited in the collection of Berezovskaya Geological-Prospecting Party (Berezovskii town, Sverdlovsk District, Russia). Bushmakinite occurs in assemblage formed in result of oxidation of a tetrahedrite-galena nest situated in a quartz vein. It forms aggregates of bright yellow lamellar crystals up to 0.02 x 0.2 x 0.3 mm. Associated minerals are cerussite, bindheimite, vauquelinite, mottramite and pyromorphite (Pekov *e.a.*, 2002c).

Name: in the memory of Anatolii Filippovich BUSHMAKIN (1947–1999), Russian mineralogist, for his significant contribution to the mineralogy of the Urals and especially to the mineralogy of oxidized zone of the Berezovskoye deposit; Institute of Mineralogy of Urals Branch of Russian Academy of Sciences, Miass.

IMA No.: 2001-031. *TS:* FMM 91015; Urals Geological Museum, Ekaterinburg.

BUSSENITE, $\text{Na}_2\text{Ba}_2\text{Fe}^{2+}\text{TiSi}_2\text{O}_7(\text{CO}_3)(\text{OH})_3\text{F}$ photo 7

Bussenite was discovered in dumps of the Kirovskii Mine, Kukisvumchorr Mt., Khibiny massif, Kola Peninsula, Russia. It occurs in axial zone of a sodalite-natro-

lite-calcite veinlet with aegirine, biotite, gonnardite, vinogradovite, titanite, eudialyte, barytoalcite, fluorapatite, fluorite, djerfisherite and molybdenite. Bussenite is visually similar to lamprophyllite. It forms yellow-brown lamellae (up to 5 mm) combined in dendrite-like clusters (Khomyakov *e.a.*, 2001a).

Name: in honour of Irina Vladislavovna BUSSEN (b. 1915), Russian mineralogist, petrologist and geologist, in recognition of her great contribution to the study of Khibiny-Lovozero alkaline complex; Geological Institute of Kola Branch of USSR Academy of Sciences, Apatity.

IMA No.: 2000-035. *TS:* FMM 91036.

BYKOVAITE, $\text{BaNa}\{(\text{Na,Ti})_4[(\text{Ti,Nb})_2(0,\text{OH})_3\text{Si}_4\text{O}_{14}](\text{OH,F})_2\}\cdot 3\text{H}_2\text{O}$ photo 8

Bykovaite was discovered in the Shkatulka pegmatite, Umbozero underground mine, Alluaiv Mt., Lovozero massif, Kola Peninsula, Russia. It occurs as cream-coloured radial fibrous spherulites up to 5 mm in diameter and their clusters up to 3 cm embedded in ussingite or situated on the margin between ussingite and vuonnemite. Other associated minerals are bornemanite, shkatulkalite, lomonosovite, steenstrupine-(Ce), belovite-(Ce), sphalerite *etc.* Partial pseudomorphs of bykovaite after bornemanite, a structurally and chemically related mineral, were observed (Khomyakov *e.a.*, 2005a). Earlier bykovaite was briefly reported as "mineral M72" (Khomyakov, 1995).

Name: in the memory of Aleksandra Vasil'evna BYKOVA (1917–2001), Russian chemist-analyst, who analysed many new minerals; Institute of Mineralogy, Geochemistry, and Crystallography of Rare Elements, Russian Academy of Sciences (IMGRE), Moscow.

IMA No.: 2003-034. *TS:* PMM r2869/2.

CADMOINDITE, CdIn_2S_4

Linnaeite group

Cadmoindite was discovered in the products of active fumaroles ($t = 450\text{--}600^\circ\text{C}$) of Kudriavyy Volcano, Medvezh'ya (Bear's) Caldera, Iturup Island, Kurily Archipelago, Russia. It occurs as black to dark red-brown well-shaped octahedral crystals up to 0.15 mm in cavities. Associated minerals are pyrite, wurtzite and rheniite (Chaplygin *e.a.*, 2004).

Name: reflects chemical composition.

IMA No.: 2003-042. *TS:* FMM 92101, 92102.

CARBOKENTBROOKSITE, $(\text{Na},\square)_{12}(\text{Na,Ce})_3\text{Ca}_6\text{Mn}_3\text{Zr}_3\text{Nb}(\text{Si}_{25}\text{O}_{73})(\text{OH})_3(\text{CO}_3)\cdot\text{H}_2\text{O}$

Eudialyte group

Carbokentbrooksit was discovered in a specimen from the moraine of the Darai-Pioz Glacier, southern slope of the Alai Range, Tadjikistan. It was found by V.D. Dusmatov in a lump of an alkaline pegmatite which mainly consists of microcline and quartz, with subordinate stillwellite-(Ce), turkestanite ("ekanite"), polyolithionite, titanite, pyrochlore, fluorite *etc.* Eudialyte-group minerals are represented by isometric zoned crystals up to 2 cm which consist of bright yellow to pinkish-yellow carbokentbrooksit core and thin (0.5–2 mm) light cream-coloured zirsilite-(Ce) rim (Khomyakov *e.a.*, 2003a).

Name: isostructural analogue of kentbrooksit with species-forming (CO_3) anion instead of F.

IMA No.: 2002-056. *TS:* FMM 92100.

CARYOCHROITE, $(\text{Na,Sr})_3(\text{Fe}^{3+},\text{Mg})_{10}[\text{Ti}_2\text{Si}_{12}\text{O}_{37}](\text{H}_2\text{O},\text{OH})_{17}$ photo 9, 10

Caryochroite was described from the Elpiditovoye pegmatite, Umbozero underground mine (the specimens were collected in dumps of the mine), Alluaiv Mt., Lovozero massif, Kola Peninsula, Russia. The mineral occurs as hazel-brown massive aggregates up to several decimeters, spherules up to 2–3 mm, their stalactite-like and botryoidal aggregates in cavities of a hydrothermally altered peralkaline pegmatite. Associated minerals are albite, elpidite, epididymite, quartz, natrolite, pyrite, galena, sphalerite and carbonate-fluorapatite. Caryochroite is the product of supergene alteration of an unidentified Fe^{2+} -rich protomineral (Kartashov *e.a.*, in press).

Name: from the Greek κάρυον (nut) and χροια (colour) and reflects hazel-brown colour of the mineral.

IMA No.: 2005-031. *TS:* FMM 92114.

CATTIITE, $\text{Mg}_3(\text{PO}_4)_2\cdot 22\text{H}_2\text{O}$

Cattiite was discovered at the open pit of the Iron Mine, Kovdor massif, Kola Peninsula, Russia. It forms colourless transparent coarse-crystalline masses up to 1.5 cm in size filling up cavities in dolomite carbonatite. Associated minerals are bakhchisaraitsevite, nastrophite, magnetite, sjogrenite and carbonate-fluorapatite (Britvin *e.a.*, 2002a).

Name: in honour of Michele CATTI (b. 1945), Italian chemist and crystallographer, for his contribution to the crystal chemistry of hydrated oxysalts (in particular, M. Catti studied the crystal structure of synthetic $\text{Mg}_3(\text{PO}_4)_2\cdot 22\text{H}_2\text{O}$); University of Milano Bicocca.

IMA No.: 2000-032. *TS:* PU 1/18618.



Intergrowths of **chabazite-Sr** crystals (phacolite twins). Suoluaiv Mt., Lovozero, Kola Peninsula, Russia. SEM image. Magnification: 500 \times . Specimen and photo: I.V. Pekov.

CERITE-(La), $(La,Ce,Ca)_9(Fe,Mg)(SiO_4)_3[SiO_3(OH)]_4(OH)_3$

Cerite-(La) was discovered in upper part of the Hackman Valley, Yukspor Mt., Khibiny massif, Kola Peninsula, Russia. It was found in axial natrolite zone of a per-alkaline pegmatite vein, with microcline, aegirine, catapleiite, edingtonite, strontianite, fluorapatite, anatase, ilmenite, *etc.* Cerite-(La) together with cerite-(Ce) and ancylite-(Ce) form cellular pseudomorphs after hexagonal prismatic crystals (up to 7 cm long) of an unidentified mineral. Cerite-(La) occurs as aggregates of pale pink-brown tabular crystals up to 2 mm (Pakhomovsky *e.a.*, 2002).

Name: La-dominant analogue of cerite-(Ce).

IMA No.: 2001-042. *TS:* no reliable information.

CHABAZITE-Sr, $(Sr,Ca)[Al_2Si_4O_{12}]\cdot 6H_2O$

Zeolite group

Chabazite-Sr was discovered in the Seidozeritovoye pegmatite, Suoluaiv Mt., Lovozero massif, Kola Peninsula, Russia. It occurs in cavities of corroded analcime crystals. Chabazite-Sr forms clusters of twinned by "phacolite law" disc-like coarse colourless or yellowish crystals up to 0.3 mm. Associated minerals are sanidine, microcline, Ca-enriched aegirine, nepheline, ilmenite, seidozerite, lavenite, fluorapatite (early pegmatitic minerals), analcime, gonnardite, paranatrolite, phillipsite-K, vinogradovite *etc.* (Pekov *e.a.*, 2000d).

Name: Sr-dominant member of the chabazite series.

IMA No.: 99-040. *TS:* FMM 89866.

CHESNOKOVITE, $Na_2[SiO_2(OH)_2]\cdot 8H_2O$

photo 11

Chesnokitite was discovered in the Kedykverpakhk area of the Karnasurt underground mine, Kedykverpakhk Mt., Lovozero massif, Kola Peninsula, Russia. It forms colourless, white or pale brownish-yellowish massive lenticular nests up to 4 x 6 x 10 cm which completely fill cavities in an ussingite vein. These nests consist of aggregates of lamellar chesnokitite crystals up to 0.05 x 1 x 2 cm. Associated minerals are natrolite, sodalite, vuonnemite, natisite, steenstrupine-(Ce), phosinaite-(Ce), vitusite-(Ce), gobbinsite, natrosilite, villiaumite, olympite, revdite and natrophosphate (Pekov *e.a.*, in press[b]).

Name: in the memory of Boris Valentinovich CHESNOKOV (1928–2005), an outstanding Russian mineralogist, a specialist in the mineralogy of supergene and technogene formations, mineralogy of alkaline hydrothermalites and crystallogensis; Institute of Mineralogy of Urals Branch of Russian Academy of Sciences, Miass.

IMA No.: 2006-007. *TS:* FMM 91965, 91966.

CHISTYAKOVAITE, $Al(UO_2)_2(AsO_4)_2(F,OH)\cdot 6.5H_2O$

photo 12

Chistyakovaite, an arsenate mineral related to threadgoldite, was discovered in specimens collected by E.V. Kopchenova in 1950s in the oxidized zone of the Bota-Burum uranium deposit, Chu-Ili Mts., South Kazakhstan. It occurs as yellow transparent coarse lamellar crystals up to 2 mm and their aggregates. Associated minerals are calcite, arsenopyrite, pyrite, galena, scorodite, arseniosiderite, mansfieldite, metazeunerite, trogerite, sodium uranospinite and uramarsite. Chistyakovaite fluoresces green in shortwave ultraviolet light (Chukanov *e.a.*, 2006b).

Name: in honour of Natalia Il'ichna CHISTYAKOVA (b. 1945), a specialist in electron microprobe analysis, who analysed many uranium minerals; All-Russian Research Institute of Mineral Resources (VIMS), Moscow.

IMA No.: 2005-003. *TS:* FMM 92110; Mineralogical Museum of VIMS: 350/59 (E.V. Kopchenova collection).

CHIVRUIITE, $\text{Ca}_3(\text{Ti,Nb})_5[(\text{Si}_6\text{O}_{17})_2(\text{OH},\text{O})_5]\cdot 14\text{H}_2\text{O}$

Chivruaiite, a Ca-analogue of zorite, was described from three localities in the Lovozero and Khibiny massifs, Kola Peninsula, Russia. In Lovozero, it was found in Chivruai River valley, in Khibiny – in two points at Eveslogchorr Mt. At Chivruai, the mineral occurs as colourless long-prismatic crystals up to 1.5 mm long and spherulites in cavities of a microcline vein, with murmanite, natrolite, whewellite, aegirine, lorenzenite, lamprophyllite, barytolamprophyllite, pectolite, analcime, hydroxylapatite *etc.* At Eveslogchorr, it was found as spherulites which consist of long-prismatic crystals up to 1.5 mm long in cavities of a natrolite-microcline vein with kuzmenkoite-Mn and as pale pink long-prismatic crystals up to 1 mm long in cavities of an astrophyllite-aegirine-microcline vein with natrolite (Men'shikov *e.a.*, 2006).

Name: for the locality in Chivruai River valley.

IMA No.: 2004-052. *TS:* KSC 6273.

CHLORARTINITE, $\text{Mg}_2(\text{CO}_3)\text{ClOH}\cdot 3\text{H}_2\text{O}$

Chlorartinite was found on the First and Third cinder cones of Northern Breakthrough and on the cinder cone of Southern Breakthrough of the Tolbachik Main Fracture Eruption (1975–1976), Tolbachik Volcano, Kamchatka, Russia. It is a product of post-eruptive alteration of pyroclastic rocks. Chlorartinite forms colourless to white fine-grained (grains up to 0.01 mm) massive aggregates. It is associated with halite, aragonite, gypsum and nesquehonite (Vergasova *e.a.*, 1998a).

Name: reflects the chemical relationship to artinite and chlorine content.

IMA No.: 96-005. *TS:* FMM 89593; PU 1/19216, PMM 2093/1.

CHLORBARTONITE, $\text{K}_6\text{Fe}_{24}\text{S}_{26}(\text{Cl,S})$

Chlorbartonite was described as a new mineral species from the Koashva Quarry of the Vostochnyi (Eastern) Mine, Koashva Mt., Khibiny massif, Kola Peninsula, Russia. It occurs in a peralkaline pegmatite with microcline, pectolite, sodalite, aegirine, natrolite, lomonosovite, annite, astrophyllite, burbankite, djerfisherite, rasvumite, fluorcaphite, villiaumite, thermonatrite, *etc.* Chlorbartonite forms black-brown roundish grains (up to 2 cm) with semi-metallic luster (Yakovenchuk *e.a.*, 2003). The same mineral was earlier described as "Cl-bartonite" with the idealized formula $\text{K}_6\text{Fe}_{20}\text{S}_{26}(\text{S}_{0.25}\text{Cl}_{0.75})$ from Coyote Peak alkaline diatreme, Humboldt Co., California, U.S.A., by G.K. Szamanske *e.a.* (1981).

Name: Cl-dominant analogue of bartonite.

IMA No.: 2000-048. *TS:* PMM 3108.

CHLOROMENITE, $\text{Cu}_9\text{O}_2(\text{SeO}_3)_4\text{Cl}_6$

Chloromenite was found in 1977 in the sublimates of the Novaya (New) Fumarole on the western border of the Second cinder cone, Northern Breakthrough of the Tolbachik Main Fracture Eruption (1975–1976), Tolbachik Volcano, Kamchatka, Russia. The mineral occurs as tobacco-green transparent elongate lamellar crystals up to 0.2 mm associated with melanothallite and sofiite (Vergasova *e.a.*, 1999a).

Name: from the Greek $\chi\lambda\alpha\rho\omicron\varsigma$ (green; also indicates chlorine) and $\mu\eta\nu\alpha\zeta$ (moon indicating selenium).

IMA No.: 96-048. *TS:* FMM 89589.

CHROMCELADONITE, $\text{KCrMg}[\text{Si}_4\text{O}_{10}](\text{OH})_2$ photo 13 Mica group

Chromceladonite was described as a new mineral at Srednyaya Padma PGE-Au-U-V deposit, Zaonezhskiy Peninsula (Onezhskoye Lake), South Karelia, Russia. It is a

Chloromenite crystal
(Vergasova *e.a.*, 1999a).

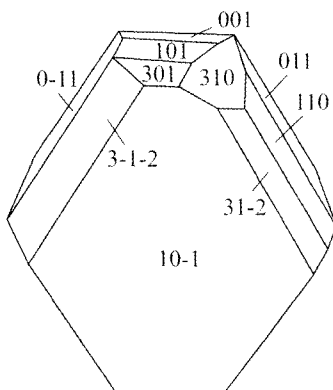

Chukanovite aggregates:

a – spherulitic crust, b – spherulite.
Dronino meteorite, Dronino village,
Kasimov area, Ryazan' District, Russia.
SEM image. Specimen and photo: I.V. Pekov.

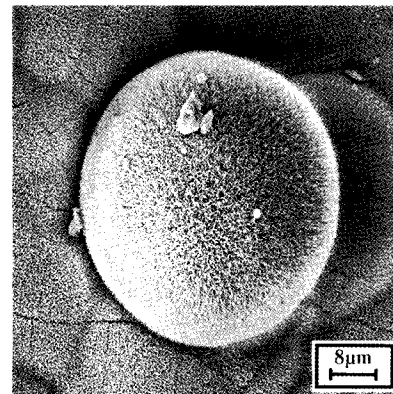
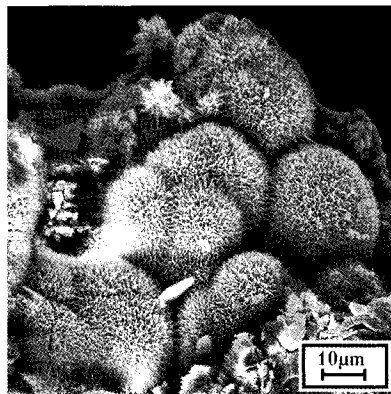

rock-forming mineral of specific dolomite-chromceladonite-roscobelite metasomatites. The mineral forms spherulites up to 1 cm in diameter and massive chaotic aggregates which consist of curved scales up to 3 mm. Chromceladonite is green: from emerald-green to dark green, sometimes with grayish or brown tint. Associated minerals are dolomite, roscobelite, chromphyllite, quartz, calcite, hematite, uraninite, zincochromite, coffinite, selenides of Pb, Bi, Pd and Ag, vanadium oxides *etc.* (Pekov *e.a.*, 2000b). The mineral was firstly found at the same locality by E.V. Rumyantseva *e.a.* (1984) and shortly described as "chromian phengite".

Name: Cr-dominant analogue of celadonite.

IMA No.: 99-024. *TS:* FMM 89653.

CHUKANOVITE, $Fe_2(CO_3)(OH)_2$

Chukanovite, a Fe-mineral related to rosasite-group members, pokrovskite and malachite, was discovered in the Dronino ataxite iron meteorite (fell in prehistoric time) found in 2000 near Dronino village, Kasimov area, Ryazan' District, 350 km southeast of the city of Moscow, Russia. The mineral is a product of terrestrial alteration ("corrosion") of meteoritic iron. Chukanovite was found in small cavities of partially weathered fragments of the meteorite. It occurs as acicular to fibrous crystals (up to 0.5 mm long and up to 2–3 mm thick) combined in spherulites up to 0.3 mm (rarely up to 1 mm) in diameter and parallel- or radial-fibrous crusts up to 1 mm thick. Botryoidal aggregates of the spherulites are typical. Unaltered chukanovite is pale-green to colourless. It becomes brownish-green and further brown in air for several months. Associated minerals are goethite, akaganeite, hematite, magnetite, siderite, reevesite and honessite; relic minerals of unaltered meteorite are kamacite, taenite, troilite, Fe-Ni sulfides and chromite (Pekov *e.a.*, in press[d]).

Name: in honour of Nikita Vladimirovich CHUKANOV (b. 1953), Russian physicist and mineralogist, a specialist in infrared spectroscopy of minerals and synthetic compounds, discoverer of many new minerals; Institute of Problems of Chemical Physics of Russian Academy of Sciences, Chernogolovka, Moscow District.

IMA No.: 2005-039. *TS:* FMM 92013.

CHUKHROVITE-(Nd), $Ca_3(Nd,Y)Al_2(SO_4)F_{13} \cdot 12H_2O$

Chukhrovite-(Nd) was discovered in specimens from Kara-Oba Mo-W deposit, Betpakdala Desert, Central Kazakhstan. It was found in two assemblages. The holotype specimen is a fragment of huebnerite-quartz vein with cavities in which jarosite,

Chukhrovite-(Nd) crystals. Kara-Oba,
Betpakdala Desert, Kazakhstan. SEM image.
Scale bar length is 10 μ m. Specimen and
photo: L.A. Pautov.

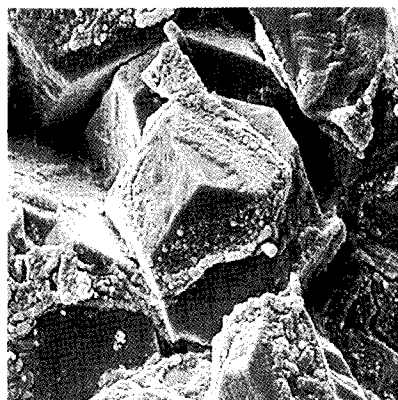

Clinobarylite crystals
(Chukanov e.a., 2003a).

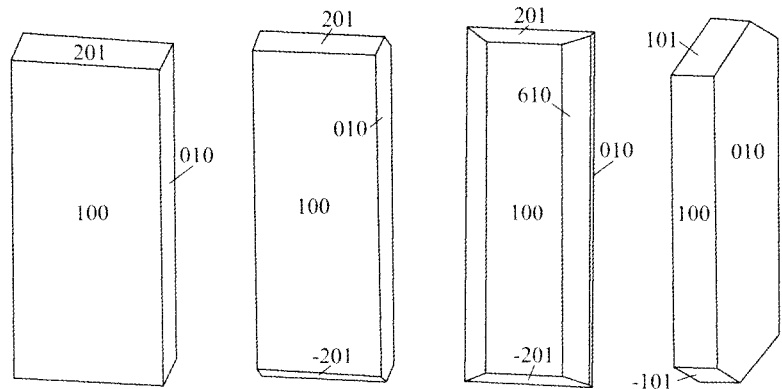

anglesite, creedite, gearsutite, halloysite and chukhrovite-(Nd) occur. The latter forms colourless equant grains and coarse cubo-octahedral crystals up to 0.4 mm. Also the mineral was found in specimen no. 1208 from V.I. Stepanov collection deposited in Fersman Mineralogical Museum of Russian Academy of Sciences, Moscow. This specimen is labelled: "Chukhrovite. Clusters of pinkish cubo-octahedra with white gearsutite. Karaoba, vein no. 8, Djambul Mine, NE Akdala, Central Kazakhstan. Collected in 1950 by V.I. Stepanov". Chukhrovite crystals up to 1 mm together with plumbojarosite, beudantite, gearsutite and halloysite occur in cavities of a quartz vein with ferberite and pyrite. These crystals show the concentric zoning: thin zones of chukhrovite-(Y) and chukhrovite-(Nd) alternate (Pautov e.a., 2005).

Name: Nd-dominant analogue of chukhrovite-(Y) and chukhrovite-(Ce).
IMA No.: 2004-023. *TS:* FMM 91649.

CLINOBARYLITE, $\text{BaBe}_2\text{Si}_2\text{O}_7$

photo 14

Clinobarylite was discovered in four peralkaline pegmatite veins in upper part of the Hackman Valley, Yukspor Mt., Khibiny massif, Kola Peninsula, Russia. It forms colourless lamellar to prismatic crystals up to 1 x 4 x 20 mm and their radiating aggregates. Associated minerals are natrolite, aegirine, microcline, catapleite, fluorapatite, titanite, fluorite, galena, sphalerite, strontianite, annite, astrophyllite, lorenzenite, cerite-(Ce), edingtonite, ilmenite, anatase etc. (Chukanov e.a., 2003a). Note that later S.V. Krivovichev e.a. (2004) studied a sample from one of these pegmatites and found that its structure motif and unit cell dimensions *a*, *b* and *c* are the same as for clinobarylite (but not barylite) however the space group is not *P1m1* (as it was given in original papers on clinobarylite: Rastsvetaeva, Chukanov, 2003; Chukanov e.a., 2003a) but *Pmn2*₁. From these data, they supposed that clinobarylite is orthorhombic but not monoclinic and can be presented as the polytype barylite-1*O* whereas "true" barylite – as the polytype barylite-2*O* (Krivovichev e.a., 2004). However these data were obtained not for the type specimen and therefore this conclusion is groundless for original clinobarylite.

Name: reflects monoclinic symmetry and dimorphism with barylite.
IMA No.: 2002-015. *TS:* FMM 91049.

COPARSITE, $\text{Cu}_4\text{O}_2[(\text{As,V})\text{O}_4]\text{Cl}$

Coparsite was discovered in the Yadovitaya (Poisonous) Fumarole, the Second cinder cone, Northern Breakthrough of the Tolbachik Main Fracture Eruption (1975–1976), Tolbachik Volcano, Kamchatka, Russia. It occurs as black or dark gray grains, rarely tabular crystals up to 0.1 x 0.2 x 0.4 mm, included in euchlorine. Other

Coparsite crystal (Vergasova e.a., 1999c).

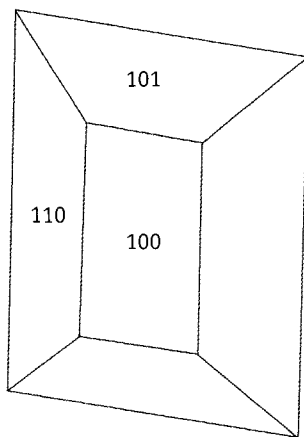

associated minerals are hematite, tenorite, V-rich lammerite, klyuchevskite – alumoklyuchevskite series members, tolbachite *etc.* (Vergasova *e.a.*, 1999c).

Name: for the chemical composition: copper + arsenic.

IMA No.: 96-064. *TS:* PMM: mgs2121/1.

DASHKOVAITE, $\text{Mg}(\text{HCO}_2)_2 \cdot 2\text{H}_2\text{O}$

Dashkovaite was discovered in the core of a borehole at the Korshunovskoye Fe deposit, Irkutsk District, Siberia, Russia. Veinlets (up to 1 mm thick) with dashkovaite cross-cut dolomite marble. The mineral occurs as white fine-fibrous aggregates (fibra up to 0.01 x 3 mm) and massive nests which consist of lamellar crystals <0.01 mm. Associated minerals are shabynite, iowaite, ekaterinite, korshunovskite, halite, hydromagnesite and serpentine (Chukanov *e.a.*, 2000).

Name: in the memory of Princess Ekaterina Romanovna DASHKOVA (1744–1810), Russian enlightener, Director of Saint-Petersburg Academy of Sciences and President of Russian Academy of Sciences in the period of 1783-1796.

IMA No.: 2000-006. *TS:* FMM 81597.

DIVERSILITE-(Ce), $(\text{Ba,K,Na,Ca})_{11-12}(\text{REE,Fe,Th})_4(\text{Ti,Nb})_6(\text{Si}_6\text{O}_{18})_4(\text{OH})_{12} \cdot 4.5\text{H}_2\text{O}$ photo 15

Diversilite-(Ce) was described as a new mineral species from two peralkaline pegmatites at Yukspor Mt., Khibiny massif, Kola Peninsula, Russia. The holotype specimen was found in dumps of a tunnel built in the end of 1980s near the mouth of the Hackman Valley. Diversilite-(Ce) occurs in cavities of a peralkaline pegmatite, with nepheline, sodalite, K-feldspar, natrolite, pectolite, aegirine, shcherbakovite, lamprophyllite, magnesium astrophyllite, delindeite, wadeite, umbite and kostylevite. The mineral forms yellowish-orange to cream-coloured fan-like clusters of lamellar crystals (up to 3 mm) and spherulites (Khomyakov *e.a.*, 2003c). Earlier diversilite-(Ce) was found in cavities in another pegmatite at the same mountain, as yellow hexagonal lamellae up to 3 mm with natrolite, pectolite and villiaumite, and reported as "mineral M30" (Khomyakov, 1995). Note that diversilite-(Ce) was originally described with the formula $\text{Na}_2(\text{Ba,K})_6\text{Ce}_2\text{Fe}^{2+}\text{Ti}_3[\text{Si}_3\text{O}_9]_3[\text{SiO}_3\text{OH}]_3(\text{OH,H}_2\text{O})_9$ (Khomyakov *e.a.*, 2003c) obtained from the crystal structure data by R.K. Rastsvetaeva *e.a.* (2003). However, as it was shown later (Krivovichev *e.a.*, 2004), this structure model is wrong. In particular, mixed tetrahedral complexes formed by three-membered rings $[\text{Si}_3\text{O}_9]$ and isolated $[\text{SiO}_3\text{OH}]$ tetrahedra described by R.K. Rastsvetaeva *e.a.* (2003) were replaced by six-membered $[\text{Si}_6\text{O}_{18}]$ rings in the model given by S.V. Krivovichev *e.a.* (2004). As result, the formula of diversilite-(Ce) was refined in the latter paper as follows: $(\text{Ba,K,Na,Ca})_{11-12}(\text{REE,Fe,Th})_4(\text{Ti,Nb})_6(\text{Si}_6\text{O}_{18})_4(\text{OH})_{12} \cdot 4.5\text{H}_2\text{O}$.

Name: reflects the complex character of the Si,O-polyanion consisting of three-membered rings $[\text{Si}_3\text{O}_9]$ and isolated $[\text{SiO}_3\text{OH}]$ tetrahedra: from the Latin *diversus* (heterogeneous) and *silicate* (in the light of new data, this name became non-reflecting the crystal structure features however it is preserved as original name given by authors, like some other similar cases in mineralogical nomenclature – I.P.).

IMA No.: 2002-043. *TS:* FMM 91658.

DUALITE, $\text{Na}_{30}(\text{Ca,Na,Ce,Sr})_{12}(\text{Na,Mn,Fe,Ti})_6\text{Zr}_3\text{Ti}_3\text{MnSi}_{51}\text{O}_{144}(\text{OH,H}_2\text{O,Cl})_9$ *Eudialyte group*

Dualite was discovered in the core of a borehole at Alluaiv Mt., Lovozero massif, Kola Peninsula, Russia. It occurs as yellow irregular grains up to 0.5 mm among crimson "ordinary" eudialyte in a peralkaline pegmatoid rock. Other associated minerals are K-feldspar, nepheline, sodalite, cancrinite, aegirine, alkali amphibole, lovozerite, lomonosovite, vuonnemite, lamprophyllite, sphalerite and villiaumite (Khomyakov *e.a.*, in press[b]).

Name: from the Latin *dualis* (dual) that reflects dual position of the mineral in nomenclature: it is not only Zr-silicate but also Ti-silicate, with two types of M,Si,O complexes: $\{\text{Zr}_3[\text{Si}_3\text{O}_9]_2[\text{Si}_9\text{O}_{27}]_2\}$ and $\{\text{Ti}_3[\text{Si}_3\text{O}_9]_2[\text{Si}_9\text{O}_{27}]_2\}$.

IMA No.: 2005-019. *TS:* FMM 92097.

EDGARITE, FeNb_3S_6

Edgarite was discovered at Kaskasnyunchorr Mt., Khibiny massif, Kola Peninsula, Russia. It was found in a fenitized xenolith of gneiss (?) situated among nepheline syenites. It forms dark gray lamellae (up to 0.15 mm) with metallic luster, visually similar to dark molybdenite, and their aggregates on pyrrhotite and also inclusions in pyrrhotite and alabandite. Other associated minerals are anorthoclase, phlogopite, rutile, corundum, monazite-(Ce), W-bearing molybdenite, marcasite *etc.* (Barkov *e.a.*, 2000a).

Name: in honour of Alan Douglas EDGAR (1935–1998), Canadian petrologist and mineralogist, in recognition of his important contribution to the study of alkaline rocks; University of Western Ontario, London, Ontario, Canada.

IMA No.: 95-017. *TS:* Royal Ontario Museum, Toronto: M46177T.

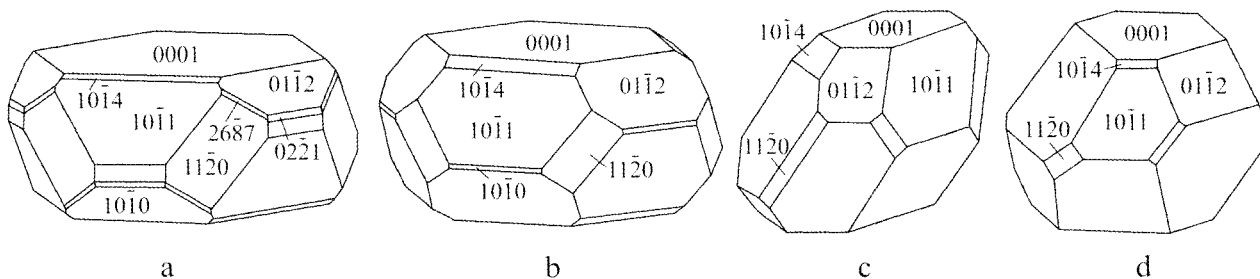

Idealized (a – b) and real (c – d) feklischevite crystals (Pekov *e.a.*, 2001b).

EVESLOGITE, $(\text{Ca,K,Na,Sr,Ba})_{48}[(\text{Ti,Nb,Fe,Mn})_{12}(\text{OH})_{12}\text{Si}_{48}\text{O}_{144}] (\text{F,Cl,OH})_{14}$ photo 16

Eveslogite was described in two points in the area of Eveslogchorr Mt., Khibiny massif, Kola Peninsula, Russia. In the mouth of Fersman Gorge (the holotype), it forms almost monomineral vein (5–15 cm thick and 3.7 m long, as it was observed on outcrop) cross-cutting gneiss-like ristschorrite. The vein consists of light brown to yellow plicated fine-fibrous aggregates of eveslogite with inclusions of K-feldspar, nepheline, biotite, fluorapatite, shcherbakovite, eudialyte and astrophyllite. Another find was represented by several pieces of eveslogite rock in an alluvial deposit. Eveslogite is very similar visually to yuksporite, a mineral related in the chemistry and crystal structure (Menshikov *e.a.*, 2003).

Name: for the locality.

IMA No.: 2001-023. *TS:* KSC 6236.

FEKLICHEVITE, $\text{Na}_{11}\text{Ca}_9(\text{Fe}^{3+},\text{Fe}^{2+})_2\text{Zr}_3\text{Nb}[\text{Si}_{25}\text{O}_{73}](\text{OH},\text{H}_2\text{O},\text{Cl},\text{O})_5$ photo 17

Eudialyte group

Feklichevite was discovered in the open pit of the Mica Mine, Kovdor massif, Kola Peninsula, Russia. First specimens were collected by I.V. Pekov and N.A. Pekova in 1990. The mineral occurs in a pegmatoid cancrinite syenite vein, with orthoclase, cancrinite, aegirine-diopside, pectolite, titanite *etc.* Feklichevite forms well-shaped isometric and thick-tabular dark-brown crystals and grains up to 2.5 cm (Pekov *e.a.*, 2001b). As it was found later, feklischevite is typical accessory to rock-forming mineral of Ca-enriched cancrinite syenites and related pegmatites in Kovdor massif.

Name: in the memory of Vladimir Georgievich FEKLICHEV (1933–1999), Russian mineralogist and crystallographer, a specialist in optical methods of mineral studies, for his significant contribution to the study of eudialyte-group minerals; Institute of Mineralogy, Geochemistry, and Crystallography of Rare Elements, Russian Academy of Sciences (IMGRE), Moscow, and Moscow Mining Institute.

IMA No.: 2000-017. *TS:* FMM 91014.

FERRIWINCHITE, $\text{NaCaMg}_4\text{Fe}^{3+}[\text{Si}_8\text{O}_{22}](\text{OH},\text{F})_2$ *Amphibole group*

Ferriwinchite was described as a new mineral species from an outcrop 1 km east of the Selyankinskii Cordon of the Ilmeny Natural Reserve, Ilmeny Mts., South Urals, Russia. It occurs in quartz-winchite veinlets with pyrite cross-cutting pyroxene fenites. Ferriwinchite forms thin black rim on blue-black winchite crystals and also occurs as thin-acicular to fibrous crystals up to 7 cm long in cavities (Bazhenov *e.a.*, 2005).

Name: Fe^{3+} -dominant analogue of winchite.

IMA No.: 2004-034. *TS:* IR 8987; VGM 56505.

Ferriwinchite trilling from Pit #97, Ilmeny Mts. (after V.A. Popov).

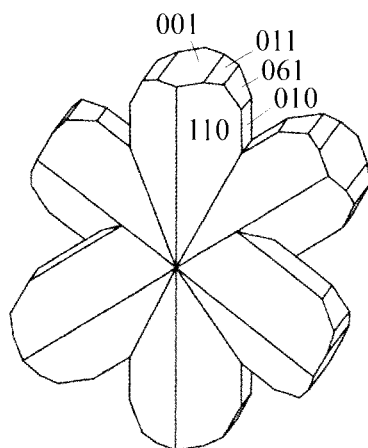

FERRONORDITE-(Ce), $\text{Na}_3\text{SrCeFeSi}_6\text{O}_{17}$

photo 18

Nordite group

Ferronordite-(Ce) was first described at two points of the Lovozero alkaline massif, Kola Peninsula, Russia. The holotype specimen was found in the Chinglusai River valley. It is an old specimen from V.I. Stepanov collection (No. 4725, labelled "nordite"; collected by E.M. Es'kova in 1950s), which is now deposited in Fersman Mineralogical Museum of Russian Academy of Sciences, Moscow. In this specimen, ferronordite-(Ce) is represented by brownish tabular crystals to 1 x 5 x 8 mm combined in fan-shaped clusters up to 1 cm in diameter. It occurs in small cavities of pegmatoid naujaite together with sodalite, aegirine, ussingite, lomonosovite, eudialyte, hisingerite *etc.* In 1995, ferronordite-(Ce) was found at Karnasurt Mt. in the wasterock from deep levels of the operating mine. It occurs in an ussingite veinlet as spherulites to 5 mm composed of colourless transparent lamellar crystals. Associated minerals are vuonnemite, natisite, serandite, steenstrupine-(Ce), thorosteenstrupine, kazakovite *etc.* (Pekov *e.a.*, 1998a).

Name: Fe²⁺- and Ce-dominant member of the nordite group.

IMA No.: 97-008. *TS:* FMM 88828 (and #4725 in V.I. Stepanov collection).

FERRONORDITE-(La), $\text{Na}_3\text{Sr(La,Ce)FeSi}_6\text{O}_{17}$

photo 19

Nordite group

Ferronordite-(La) was discovered at Bol'shoy Punkaruiv Mt., Lovozero massif, Kola Peninsula, Russia. It occurs as colourless to pale-brown spherulites up to 1.5 cm in diameter which consist of tabular crystals up to 1 x 5 x 8 mm; margin zone of some spherulites consists of ferronordite-(Ce). The mineral was found in the ussingite core of a small peralkaline pegmatite, with aegirine, epistolite, sphalerite, steenstrupine-(Ce) and altered serandite (Pekov *e.a.*, 2001a).

Name: Fe²⁺- and La-dominant member of the nordite group.

IMA No.: 2000-015. *TS:* FMM 90286.

FERRORHODSITE, $(\text{Fe,Cu})(\text{Rh,Pt,Ir})_2\text{S}_4$

Linnaeite group

Ferrorhodsite was firstly described in placer platinum deposits related to two alkaline-ultramafic massifs in the Khabarovsk Territory, Russia. In the placer deposit of the Mokhovoy Stream at the Chad massif, ferrorhodsite, laurite and osmium occur as inclusions in isoferroplatinum. In the Konder massif, isoferroplatinum grains contain inclusions of ferrorhodsite, hollingworthite and laurite. At both localities, ferrorhodsite forms irregular iron-black grains up to 0.05 x 0.07 mm, with metallic luster (Rudashevskii *e.a.*, 1998).

Name: reflects the chemical composition: *ferrum* (iron), *rhodium*, sulfur.

IMA No.: 96-047. *TS:* FMM 89312.

FERROSAPONITE, $\text{Ca}_{0.3}(\text{Fe}^{2+},\text{Mg},\text{Fe}^{3+})_3(\text{Si,Al})_4\text{O}_{10}(\text{OH})_2 \cdot 4\text{H}_2\text{O}$

photo 20

Smectite group

Ferrosaponite was described as a new mineral species from the Levoberezh'e iceland spar deposit, Nizhnyaya Tunguska River basin, Evenk Autonomous District, Siberia, Russia. It is a hydrothermal mineral related to the basalt pillow lavas. Ferrosaponite forms dark-green spherules up to 2 mm in diameter included into crystals of transparent calcite – iceland spar. Associated minerals are pyrite, quartz (chalcedony), mordenite, heulandite-Ca and stilbite-Ca (Chukanov *e.a.*, 2003b).

Name: Fe²⁺-analogue of saponite.

IMA No.: 2002-028. *TS:* FMM 91298; Geoscience Collections of Freiberg University of Mining and Technology, Freiberg, Germany: 80252.

FILATOVITE, $\text{K}[(\text{Al,Zn})_2(\text{As,Si})_2\text{O}_8]$

Feldspar group

Filatovite, the first arsenate member of the feldspar group, was discovered in the products of an active fumarole (t~ 410–420°C) of the Second cinder cone, Northern Breakthrough of the Tolbachik Main Fracture Eruption (1975–1976), Tolbachik Volcano, Kamchatka, Russia. It occurs as colourless, transparent prismatic crystals up to 0.3 mm and their clusters. Associated minerals are As-bearing orthoclase, alumoklyuchevskite, hematite, tenorite, lammerite, johillerite and sylvite (Vergasova *e.a.*, 2004a).

Name: in honour of Stanislav Konstantinovich FILATOV (b. 1940), Russian crystallographer, for his important contributions to high temperature crystal chemistry and crystal chemistry of volcanic exhalation minerals; Department of Crystallography of Saint-Petersburg State University.

IMA No.: 2002-052. *TS:* PU 1/19086.

FLUORCALCIOBRITHOLITE, $(Ca,REE)_5[(Si,P)O_4]_3F$ *Britholite group*

Fluorcalciobriholite has been described as a new mineral species from several localities in Russia. The holotype specimen (crystalline fluorcalciobriholite) was found in 1977 by Yu.P. Men'shikov on the eastern slope of Kukisvumchorr Mt., at the source of Tuliok river, Khibiny massif, Kola Peninsula. Three co-type localities are in Siberia: the Burpala alkaline massif, Northern Baikal Region, Buryatia, the Sol'skoye REE deposit, Buryatia, and the Ulan-Erge alkaline massif, Sangilen Uppland, Tuva (Tyva). In Siberian localities, a metamictic mineral occurs. In Khibiny, fluorcalciobriholite forms transparent pale pinkish to brown prismatic hexagonal crystals up to 0.5 x 10 mm in veinlets which consist of orthoclase, nepheline, sodalite and biotite and contain subordinate fayalite, gadolinite-(Ce), zircon, monazite-(Ce), zirconolite ("polymignite"), fluorapatite, fluorite, molybdenite, lollingite and graphite. These veinlets cross-cut a fenitized gneiss xenolith situated in foyaite. In Burpala, fluorcalciobriholite together with visually indistinguishable fluorbritholite-(Ce) and britholite-(Ce) occur as massive fine-grained nodules up to 50 cm in a pegmatoid syenite, with K-feldspar, albite, alkali pyroxene, fluorapatite and natrolite. Other two studied samples are stored in the collections of the Fersman Mineralogical Museum of Russian Academy of Sciences, Moscow. A sample from Sol'skoye, with catalogue no. 62388, (donated in 1961 by A.I. Ginzburg) consists of a single massive monomineral piece (10 cm in size) of fluorcalciobriholite from alkaline metasomatic rock. A sample from Ulan-Erge, with catalogue no. 67445, (donated in 1965 by V.I. Korkin) consists of a vial with grains (1–2 mm each) of fluorcalciobriholite with calcite ingrowths, probably from alkaline metasomatite. Also several earlier published chemical analyses of "britholite" from different localities corresponding to fluorcalciobriholite are known (Pekov *e.a.*, in press[c]).

Name: F- and Ca-dominant analogue of britholite-(Ce) and britholite-(Y).

IMA No.: 2006-010. *TS:* FMM 91967 (holotype), 62388, 67445.

FLURO-MAGNESIO-ARFVEDSONITE, $NaNa_2(Mg,Fe^{2+})_4Fe^{3+}[Si_8O_{22}](F,OH)_2$ *Amphibole group*

Fluro-magnesio-arfvedsonite was described as a new mineral species from several places of the Ilmeny Mts. and Vishnevy Mts., both South Urals, Russia. The holotype specimen was found on the western slope of the Ilmeny Mts. There is a rock-forming mineral of leucocratic fenite associated with microcline, albite, phlogopite, rutile and zircon. It occurs as gray coarse prismatic crystals up to 0.7 mm. In the Vishnevy Mts., fluoro-magnesio-arfvedsonite and phlogopite form rims surrounding carbonatite veins and containing also magnetite, ilmenite, pyrrhotite, pyrochlore, fluorapatite, zircon and monazite-(Ce). Fluoro-magnesio-arfvedsonite occurs as black prismatic crystals and grains up to 10 cm long (Bazhenov *e.a.*, 2000).

Name: F-dominant analogue of magnesio-arfvedsonite.

IMA No.: 98-056. *TS:* PMM r2876; IR iz7419.

FLURO-SODIC-PEDRIZITE, $NaLiMg_2Al_2LiSi_8O_{22}(F,OH)_2$ *Amphibole group*

Fluro-sodic-pedrize was discovered in result of re-examination of the type specimen of clinoholmquistite from the Tastyg spodumene deposit, Tuva (Tyva), Siberia, Russia. This specimen is deposited in Fersman Mineralogical Museum of Russian Academy of Sciences, Moscow, catalogue no. 67493. It was donated by I.V. Ginzburg, the author of description of clinoholmquistite as a new amphibole (Ginzburg, 1965). As it was shown by R. Oberti *e.a.* (2005), "clinoholmquistite" in this specimen is in fact a mixture of tremolite and a new monoclinic amphibole with the ideal formula $NaLiMg_2Al_2LiSi_8O_{22}(F,OH)_2$. The latter, in accordance with IMA-accepted nomenclature of amphiboles, was named fluoro-sodic-pedrize and the name "clinoholmquistite" was discredited. It was also shown, based on crystal-chemical arguments and experimental data, that monoclinic analogue of holmquistite is unstable (Oberti *e.a.*, 2005). Fluoro-sodic-pedrize forms blue long prismatic crystals up to 0.5 mm which occur with Li-bearing tremolite, holmquistite, plagioclase and calcite at the endocontact zone of granitic pegmatite with a diabase dike (Ginzburg, 1965; Oberti *e.a.*, 2005).

Name: F- and Na-dominant of the pedrize series in the amphibole group.

IMA No.: 2004-002. *TS:* FMM 67493; Museum of Dipartimento di Scienze della Terra, Universita di Pavia: 2003-03.

FLUROVESUVIANITE, $Ca_{19}(Al,Mg,Fe^{2+})_{13}[SiO_4]_{10}[Si_2O_7]_4O(F,OH)_9$

photo 21

Vesuvianite group

Flurovesuvianite was found in 1999 on the dumps of the abandoned Lupikko iron mine, 5 km southeast of the city of Pitkaranta, South Karelia, Russia. It occurs in cavities of chloritized diopside skarn, as radiating aggregates of white acicular crystals up to



Formicaite crystals. Solongo, Buryatia, Siberia, Russia. SEM image. Magnification: 1000 \times . Specimen and photo: S.V. Malinko.

1.5 cm long and 0.005–0.02 mm thick. Thin epitactic crusts of fluorvesuvianite on vesuvianite crystals were also observed. Associated minerals are sphalerite, clinocllore and calcite (Britvin *e.a.*, 2003).

Name: F-dominant analogue of vesuvianite.

IMA No.: 2000-037. *TS:* PU 1/18619.

FORMICAITE, $\text{Ca}(\text{HCO}_2)_2$

Formicaite was discovered in two skarn boron deposits in Russia: the Solongo Fe-B deposit, Buryatia, Siberia, and the Novofrolovskoye Cu-B deposit, Tur'insk ore field, North Urals. At Solongo, it forms nests up to 0.1 x 1.5 x 1.5 mm in polymineral (together with calcite, frolovite, pentahydroborite, hexahydroborite, vimsite, szaibelyite and lizardite) veinlets cross-cutting kurchatovite-sakhaite rock also containing fedorovskite, turneurite, johnbaumite, ludwigite, magnetite, sphalerite and dolomite. At Novofrolovskoye, formicaite was found as a monomineral veinlet in skarned marble, with pentahydroborite, frolovite, calciborite, uralborite, vesuvianite and calcite. The mineral forms white or bluish fine-scale aggregates, which consist of scales up to 0.03 mm, or powdery masses (Chukanov *e.a.*, 1999b). Formicaite is first formate mineral.

Name: reflects chemical composition: formate (*formiate*, from Russian) of calcium.

IMA No.: 98-030. *TS:* FMM 89505.

GEORGBARSANOVITE, $\text{Na}_{12}(\text{Mn,Sr,REE})_3\text{Ca}_6\text{Fe}_3^{2+}\text{Zr}_3\text{NbSi}_{25}\text{O}_{76}\text{Cl}_2\cdot\text{H}_2\text{O}$ *Eudialyte group*

Georgbarsanovite was found in upper part of the Petrelius River valley, Khibiny massif, Kola Peninsula, Russia. It is a mineral with complicated history. It was first described by M.D. Dorfman *e.a.* (1963) as a monoclinic dimorph of trigonal eudialyte and named barsanovite. B.E. Borutskii *e.a.* (1968) found that barsanovite is trigonal, and this mineral was discredited (Fleischer, 1969). Later the refinement of the structure of original sample of "barsanovite" was completed by R.K. Rastsvetaeva *e.a.* (1990), who has demonstrated that it differs from eudialyte: Nb occupies the independent site (instead of Si in eudialyte) and Mn prevails over Na in another site. In the end of 1990s, A.P. Khomyakov with co-authors re-studied barsanovite and made an attempt of its revalidation with old name but the members of the IMA CNMMN had just objections on this name: barsanovite was originally defined as a monoclinic mineral and the transfer of this name to a trigonal mineral causes a muddle. In result, the mineral was accepted by the IMA CNMMN with a new name georgbarsanovite derived from the name of the same person (Khomyakov *e.a.*, 2005b). Georgbarsanovite occurs in a peralkaline pegmatite with nepheline, K-feldspar, cancrinite, albite, aegirine-augite, alkali amphibole, biotite and eudialyte. The mineral forms yellow-green veinlets up to 2 cm thick in nests of pink and red-brown eudialyte (Dorfman *e.a.*, 1963, Khomyakov *e.a.*, 2005b).

Name: in the memory of *Georgii* Pavlovich BARSANOV (1907–1991), an outstanding Russian mineralogist, famous teacher of mineralogy and specialist in history of science, Head of Department of Mineralogy of Moscow State University and Director of Fersman Mineralogical Museum of Russian Academy of Sciences, Moscow.

IMA No.: 2003-013. *TS:* FMM 61504.

GEORGBOKIITE, $\text{Cu}_5\text{O}_2(\text{SeO}_3)_2\text{Cl}_2$

Georgbokiite was found in the fumarole field of the cinder cone of the Southern Breakthrough of the Tolbachik Main Fracture Eruption (1975–1976), Tolbachik

Volcano, Kamchatka, Russia. The mineral occurs as chestnut-brown to dark brown short prismatic crystals up to 0.3 mm in fumarole sublimates. Associated minerals are ilinskite, halite, moissanite and Al-, Mg-, and Na-sulphates (Vergasova *e.a.*, 1999b). The name "bokiite" was initially proposed (Vergasova *e.a.*, 1996) but the name georgbokiite was accepted by the IMA CNMMN avoiding a muddle for "bokiite" and bokite.

Name: in honour of *Georgii Borisovich BOKII* (1909–2001), Russian crystallographer, for his significant contributions to crystal chemistry and mineralogy; Institute of Geology of Ore Deposits, Petrography, Mineralogy, and Geochemistry (IGEM), Moscow.

IMA No.: 96-015. *TS:* PU 1/18272; PMM 2091/1.

GJERDINGENITE-Ca, $K_2Ca(Nb,Ti)_4(Si_4O_{12})_2(O,OH)_4 \cdot 6H_2O$ *Labuntsovite group*

Gjerdingenite-Ca was discovered in the Pegmatite #61 in the north-eastern part of Karnasurt Mt., Lovozero massif, Kola Peninsula, Russia. It occurs as pale brown to pinkish brown fine-grained pseudomorphs after lamellar crystals of vuonnemite up to 0.5 x 6 x 10 mm in natrolite and as white split prismatic crystals up to 0.2 x 0.3 x 2 mm in cavities, with microcline, albite, aegirine, organovaite-Mn, organovaite-Zn, beryllite, epididymite, yofortierite, komarovite *etc.* (Pekov *e.a.*, in press[a]).

Name: Ca-dominant analogue of gjerdingenite-Fe.

IMA No.: 2005-029. *TS:* FMM 92111.

GLADIUSITE, $Fe_2^{3+}(Fe^{2+},Mg)_4(PO_4)(OH)_{11}(H_2O)$ photo 22

Gladiusite was described from open pit of the Iron Mine, Kovdor massif, Kola Peninsula, Russia. It occurs in vugs in dolomite carbonatite, with pyrochlore, magnetite, rutile, pyrite, catapleiite, bobierrite, rimkorolgit, juonniite, strontio whitlockite, collinsite and chlorite. The mineral forms dark green acicular crystals up to 0.007 x 0.5 mm combined in radial clusters (Liferovich *e.a.*, 2000b).

Name: in accordance with the morphology of the crystals which resemble double-edged swords (*gladius*, in Latin).

IMA No.: 98-011. *TS:* FMM 90282; Geological Museum of Institute of Geosciences, University of Oulu, Oulu, Finland: 12182.

GLAGOLEVITE, $NaMg_6[Si_3AlO_{10}](O,OH)_8 \cdot H_2O$ photo 23

Glagolevite was discovered in the open pit of the Mica Mine, Kovdor massif, Kola Peninsula, Russia. It occurs in metasomatic veins and lensoid zones in melilite rocks. These metasomatites consist of vesuvianite, glagolevite, andradite, diopside, pectolite, calcite, magnetite, phlogopite *etc.* Glagolevite forms colourless, grayish and greenish lamellae up to 3 cm and their aggregates. The mineral is close related to chlorites (Seredkin *e.a.*, 2003).

Name: in the memory of Aleksandr Andreevich GLAGOLEV (1927–1993), Russian petrologist who studied alkaline-ultrabasic complexes including Kovdor massif; Institute of Geology of Ore Deposits, Petrography, Mineralogy, and Geochemistry of Russian Academy of Sciences (IGEM), Moscow.

IMA No.: 2001-064. *TS:* FMM 91018.

GMELINITE-K, $(K,Na,Ca)_6[Al_7Si_{17}O_{48}] \cdot 22H_2O$

Zeolite group

Gmelinite-K was described as a new mineral species from Alluaiv Mt., Lovozero massif, Kola Peninsula, Russia. First specimens were collected at this locality by A.P. Khomyakov and M.F. Korobitsyn in 1979. In 1982, the proposal was submit-

Gmelinite-K crystals from Alluaiv Mt., Lovozero (after I.V. Pekov).

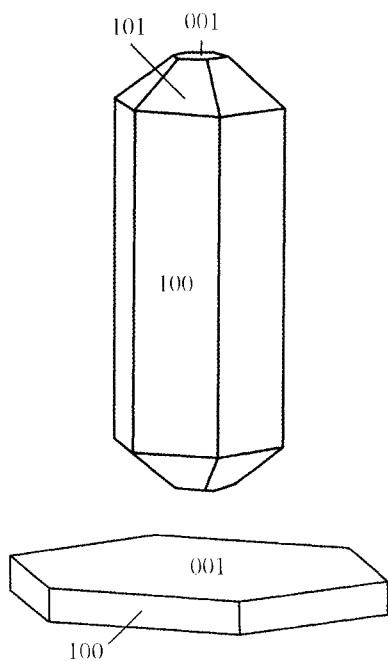

ted to the IMA CNMMN. In 1984, the crystal structure of K-dominant gmelinite from Alluaiv was reported by Yu.A. Malinovskii (1984). However long procedure of the examination of proposals on new zeolite minerals in the Subcommittee on Zeolites of the IMA CNMMN, unfortunately, led to the loss of this proposal. In result, in the final report of the Subcommittee on Zeolites of the IMA CNMMN (Coombs *e.a.*, 1997), a specimen from Fara Vicentina, Vicenza, Italy, described by G. Vezzalini *e.a.* (1990) was considered as the holotype of gmelinite-K. This mistake was improved by the decision of the IMA CNMMN 2 December 1999 and a priority of Russian research team for the mineral from Lovozero was restored. At Alluaiv, gmelinite-K occurs as crusts of colourless columnar crystals up to 0.1 x 3 mm in cracks in a peralkaline pegmatite. Also its monomineral veinlets to 5 mm thick were found. Main minerals of these pegmatites are K-feldspar, nepheline, sodalite, cancrisilite, aegirine and alkali amphiboles (Khomyakov *e.a.*, 2001c).

Name: K-dominant member of the gmelinite series.

IMA No.: 99-039. *TS:* FMM 91300.

GOLYSHEVITE, $(\text{Na,Ca})_{10}\text{Ca}_9(\text{Fe}^{3+},\text{Fe}^{2+})_2\text{Zr}_3\text{NbSi}_{25}\text{O}_{72}(\text{CO}_3)(\text{OH})_3\cdot\text{H}_2\text{O}$ photo 24 *Eudialyte group*

Golyshevite was discovered in the open pit of the Mica Mine, Kovdor massif, Kola Peninsula, Russia. It occurs in selvages of a thin vein of a calcium-rich peralkaline pegmatite cross-cutting calcite carbonatite. Golyshevite is associated with cancrinite, aegirine-augite, orthoclase, pectolite, thomsonite-Ca, tacharanite, calcite *etc.* The mineral forms brown grains up to 2 cm, rarely thick-tabular crystals, and their aggregates (Chukanov *e.a.*, 2005).

Name: in the memory of Vladimir Mikhailovich GOLYSHEV (1943–2000), Russian crystallographer, the author of one of two independently completed studies (simultaneously with G. Giuseppetti and co-authors) of crystal structure of eudialyte (1971); Mordvinian State University, Saransk, Russia.

IMA No.: 2004-039. *TS:* FMM 91775, 92105.

GUTKOVAITE-Mn, $\text{CaK}_2\text{Mn}(\text{Ti,Nb})_4(\text{Si}_4\text{O}_{12})_2(\text{O,OH})_4\cdot 5\text{H}_2\text{O}$ photo 25 *Labuntsovite group*

Gutkovaite-Mn was discovered at Malyi Mannepakhk Mt., Khibiny massif, Kola Peninsula, Russia. It occurs in a peralkaline pegmatite with microcline, aegirine, arfvedsonite, nepheline, eudialyte, albite, lorenzenite, loparite, aenigmatite, mangan-nep-tunite, murmanite, analcime, natrolite, stilbite, chabazite, kuzmenkoite-Mn, nontronite, *etc.* Gutkovaite-Mn forms pale yellowish-pink coarse prismatic crystals up to 0.8 mm long in cavities (usually on kuzmenkoite-Mn pseudomorphs after murmatite lamellar crystals) and rims surrounding corroded loparite grains (Pekov *e.a.*, 2002a).

Name: in the memory of Nina Nikolaevna GUTKOVA (1896–1960?), Russian mineralogist, active participant of mineralogical expeditions to Kola Peninsula in 1920s led by A.E. Fersman, for her significant contribution to the mineralogy of Khibiny and Lovozero alkaline massifs; Geological and Mineralogical Museum of Russian Academy of Science, Leningrad. Suffix-modifier -Mn reflects prevailing of Mn in the D site of the structure, in accordance with IMA-accepted nomenclature for labuntsovite-group minerals (Chukanov *e.a.*, 2002b).

IMA No.: 2001-038. *TS:* FMM 90616.

HENRYMEYERITE, $\text{BaFeTi}_7\text{O}_{16}$ *Cryptomelane group*

Henrymeyerite was described from level +10 m of the open pit of the Iron Mine, Kovdor massif, Kola Peninsula, Russia. It occurs in a vug in a tetraferriphlogopite-calcite-dolomite carbonatite vein, with fluorapatite, anatase, pyrite, catapleite, rimkorolgit and collinsite. The mineral forms black well-shaped tetragonal prismatic crystals up to 0.2 mm long (Mitchell *e.a.*, 2000).

Name: in the memory of Henry Oostenwald Albertjin MEYER (1937–1995), American petrologist and mineralogist, for his contribution to the study of mantle-derived xenoliths and kimberlitic rock and for his service to the mineralogical community with the Mineralogical Society of America and the IMA; Purdue University, Lafayette, Indiana, U.S.A.

IMA No.: 99-016. *TS:* no reliable information.

HEXAFERRUM, (Fe,Ru,Os,Ir)

Hexaferrum was described as a new mineral in the Chirynaitskiy massif, north-eastern part of Koryak Upland, Russian Far East, Russia. It occurs in chromite nodules in dunites and associated with osmium, rutheniridosmine, laurite, tulameenite, awaruite, iron, pentlandite, pyrrhotite, *etc.* Hexaferrum is a hexagonal Fe-dominant alloy of iron and platinum-group elements, formally hexagonal analogue of cubic iron (hexagonal structure is stabilized by PGE). Ru-, Os- and Ir-enriched varieties of hexaferrum have been described. The mineral forms steel-gray, with metallic luster, isometric grains (coarse crystals?)

up to 0.2 mm and pseudomorphs after octahedral laurite crystals (Mochalov *e.a.*, 1998).

Name: reflects symmetry and dominant chemical element.

IMA No.: 95-032. *TS:* FMM 89791.

HYDROXYLBORITE, $Mg_3(BO_3)(OH)_3$

Hydroxylborite was described as a new mineral species at the Titovskoye boron deposit, Dogdo River basin, Tas-Khayaktakh Ridge in the Chersky Mountain System, Eastern Verkhoyan'e, Polar Yakutia (Republic of Sakha-Yakutia), Siberia, Russia. It forms colourless prismatic crystals up to 0.2 x 1.5 mm and their radial aggregates in a skarned marble. Associated minerals are: calcite, dolomite, ludwigite, kotoite, szaibelyite, clinohumite, magnetite, serpentine and chlorite (Rudnev *e.a.*, 2006). Note that data on unnamed OH-dominant analogue of fluoborite from several localities were reported in literature.

Name: OH-dominant analogue of fluoborite.

IMA No.: 2005-054. *TS:* FMM 91968; Mineralogical Museum of All-Russian Research Institute of Mineral Resources (VIMS), Moscow: M-1663.

HYDROXYLCLINOHUMITE, $Mg_9(SiO_4)_4(OH,F)_2$

photo 26

Humite group

Hydroxylclinohumite was described as a new mineral in the Zelentsovskaya Pit, Protopop Mt., Magnitka town, near Zlatoust, South Urals, Russia. It was studied on the sample from Urals Geological Museum labelled "chondrodite calciphyre". Hydroxylclinohumite occurs as light-yellow, orange-yellow or colourless grains up to 3 mm and their clusters up to 2 cm in a calcite rock with spinel. The authors of the description note that analyses of hydroxyl-dominant clinohumite were published earlier for the material from several localities (Gekimyants *e.a.*, 1999).

Name: hydroxyl-dominant analogue of clinohumite.

IMA No.: 98-065. *TS:* FMM 90265.

IKRANITE, $(Na,H_3O)_{15}(Ca,Mn,REE)_6Fe_2^{3+}Zr_3(\square,Zr)(\square,Si)Si_{24}O_{66}(O,OH)_6Cl \cdot nH_2O$

photo 27

Eudialyte group

Ikranite was discovered in dumps of the Karnasurt underground mine, Lovozero massif, Kola Peninsula, Russia. It was found in a lump of a peralkaline pegmatite which consists of aegirine, microcline, lorenzenite, nepheline, lamprophyllite, murmanite and arfvedsonite, with late gonnardite and halloysite. Ikranite occurs as yellow to brown-yellow tabular grains up to 3 cm surrounded by rims of poorly studied dark brown-red to violet-red strongly hydrated eudialyte-group mineral (Chukanov *e.a.*, 2003c).

Name: for Russian acronym IKRAN: Institut Kristallografii Rossiiskoy Akademii Nauk (Institute of Crystallography of Russian Academy of Sciences), Moscow, in which crystal structures of numerous samples of eudialyte-group minerals were studied.

IMA No.: 2000-010. *TS:* FMM 91290, 91291.

ISOVITE, $(Cr,Fe)_{23}C_6$

Isovite was found in gold-platinum placer deposits of the Is River valley, Eastern part of Middle Urals, Russia. It forms irregular steel-gray grains up to 0.3 mm, with metallic luster. Some isovite grains are included in the matrix of a Fe-Cr alloy. Isovite is associated in the placer deposits with gold, cinnabar, chromite, tongbaite, PGE minerals (Generalov *e.a.*, 1998).

Name: for the type locality in Isovskoy area of the Urals.

IMA No.: 96-039. *TS:* FMM 90357.

KALIFERSITE, $(K,Na)_5Fe_7Si_{20}O_{50}(OH)_6 \cdot 12H_2O$

Kalifersite was found in the core of a borehole (depth ~~202 m~~) at Kukisvumchorr Mt., Khibiny alkaline massif, Kola Peninsula, Russia. It occurs as clusters of pink-brown fibra to 5 mm in length and aggregates to 1 cm in cavities in a peralkaline pegmatoid rock. Associated minerals include aegirine, fenaksite, sodalite, K-feldspar, nepheline, aenigmatite, lomonosovite, lamprophyllite, shcherbakovite, pectolite, loparite, natisite, paranatisite and sphalerite (Ferraris *e.a.*, 1998).

Name: reflects the chemical composition: *kalium* (potassium), *ferrum* (iron), *silicium* (silicon).

IMA No.: 96-007. *TS:* FMM 90280, 90281; also in Museo Regionale di Storia Naturale, Torino.

KANONEROVITE, $Na_3MnP_3O_{10} \cdot 12H_2O$

Kanonerovite was discovered in a specimen from the Kazyonnitsa (another spelling: Kazennitsa) pegmatite vein, Alabashka pegmatite field, Murzinka, Middle Urals, Russia. This specimen was collected in 1995 by A.A. Kanonerov in dumps of the

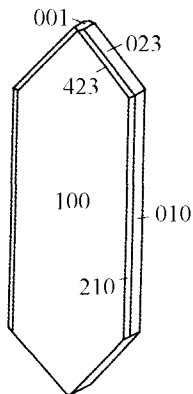

Kanonerovite crystal (Popova *e.a.*, 2002).

underground mine operated for gem beryl and topaz and mineral specimens for collectors in 1991–1993. Kanonerovite occurs as snow-white to colourless lamellar crystals combined in radial aggregates up to 1.2 mm overgrowing quartz, topaz and cassiterite in a granitic pegmatite cavity. Other associated minerals are albite, microcline, muscovite, beryl, milarite and stellerite (Popova *e.a.*, 2002).

Name: in honour of Aleksandr Anatol'evich KANONEROV (1955–2003), Russian amateur mineralogist and prominent mineral collector, a specialist in the minerals and mining history of the Urals; Museum of Mining History of the Urals, Nizhnii Tagil.

IMA No.: 97-016. *TS:* IR ms6160.

KAPITSAITE-(Y), $(\text{Ba,K})_4(\text{Y,Ca})_2\text{Si}_8(\text{B,Si})_4\text{O}_{28}\text{F}$ photo 28

Kapitsaite-(Y), an Y-dominant analogue of hyalotekite, was found in the moraine of the Darai-Pioz Glacier, southern slope of the Alai Range, Tadjikistan. It was found in 1992 in an alkaline pegmatite lump mainly consisting of quartz and containing reedmergnerite, Mn-rich pectolite, leucosphenite, polyolithionite, aegirine, turkestanite and pyrochlore. Kapitsaite-(Y) occurs as sheaf-like cluster (1 x 3 cm) which consists of pale-pink columnar grains. Y-rich variety of hyalotekite, visually indistinguishable from kapitsaite-(Y), was also found in this lump. Kapitsaite-(Y) fluoresces pale-pink in shortwave ultraviolet light (Pautov *e.a.*, 2000).

Name: in the memory of Petr Leonidovich KAPITSA (1894–1984), famous Russian physicist, Academician of USSR Academy of Sciences, an outstanding experimenter and constructor, the author of fundamental works on the physics of low-temperature processes, founder and first director of Institute of Problem of Physics, Moscow.

IMA No.: 98-057. *TS:* FMM 89495, 89502, 90423.

KAPUSTINITE, $\text{Na}_{5.5}\text{Mn}_{0.25}\text{ZrSi}_6\text{O}_{16}(\text{OH})_2$ photo 29

Lovozerite group

Kapustinite was discovered in the Palitra pegmatite, Kedykverpakhk Mt., Lovozero massif, Kola Peninsula, Russia. It forms dark cherry-coloured isometric grains from 0.5 to 4 cm (sometimes surrounded by kazakovite rim) and their clusters up to 8 cm, rarely rhombohedral crystals, in a peralkaline pegmatite. Associated minerals are microcline, aegirine, cudialyte, lorenzenite, arfvedsonite, nepheline, sodalite, analcime, ussingite, natrolite, natrosilite, manaksite, serandite, villiaumite, lomonosovite, vuonnemite, sphalerite, steenstrupine-(Ce) *etc.* (Pekov *e.a.*, 2003e).

Name: in the memory of Yuriy Leonidovich KAPUSTIN (1933–2002), Russian mineralogist and petrologist for his great contribution into the mineralogy and petrology of alkaline complexes; in particular, he actively studied the lovozerite group and first discovered three its members, namely zirsinalite, koashvite and tisinalite; Institute of Mineralogy, Geochemistry and Crystal Chemistry of Rare Elements (IMGRE), Moscow, and later Moscow Geological-Prospecting Institute (MGRI).

IMA No.: 2003-018. *TS:* FMM 91654.

KHAIDARKANITE, $\text{Cu}_4\text{Al}_3(\text{OH})_{14}\text{F}_3 \cdot 2\text{H}_2\text{O}$ photo 30

Khaidarkanite was discovered at the Plavikovaya Gora Quarry, Khaidarkan Sb-Hg deposit, northern slope of the Alai Range, Fergana Valley, Kyrgyzstan. It was first found by V.I. Stepanov in 1960s. The type specimens were collected by V.Yu. Karpenko, L.A. Pautov, A.A. Agakhanov and P.V. Khvorov in 1994 and 1995. Khaidarkanite occurs as sky-blue needle-shaped crystals up to 0.03 x 0.05 x 7 mm usually combined

in bunches, spherulites or chaotic aggregates in cavities in a quartz vein with weathered copper sulfides. Other associated minerals are calcite, barite, fluorite, malachite, allophane, conicalcalcite and chrysocola (Chukanov *e.a.*, 1999a).

Name: for the type locality.

IMA No.: 98-013. *TS:* FMM 89453.

KOKCHETAVITE, $K[AlSi_3O_8]$

Feldspar group

Kokchetavite, a metastable hexagonal polymorph of K-feldspar, was discovered in specimens from a prospecting gallery at the Kumdy-Kol' diamond deposit, near Kumdy-Kol' lake, Kokchetav (now Kokshatau) District, Northern Kazakhstan. The mineral, together with "phengite", phlogopite, titanite, calcite, zircon, cristobalite (or quartz) and siliceous glass, forms inclusions (0.003–0.007 mm) in clinopyroxene (diopside) and garnet in a diamondiferous ultra-high-pressure rock of the Kokchetav massif. This rock consists of grossular, clinopyroxene, K-feldspar, quartz and pyrrhotite (Hwang *e.a.*, 2004).

Name: for the locality in the Kokchetav ultrahigh-pressure terrane.

IMA No.: 2004-011. *TS:* National Museum of Natural Sciences, Taichung, Taiwan.

KOROBITSYNITE, $Na_{3-x}(Ti,Nb)_2[Si_4O_{12}](OH,O)_2 \cdot 3-4H_2O$

photo 31

Labuntsovite group

Korobitsynite, a Ti-dominant analogue of nenadkevichite, was first described in two points of the Lovozero massif, Kola Peninsula, Russia. The holotype specimen was found in the Shomiokitovoye pegmatite, Umbozero underground mine, Alluaiv Mt., co-type locality is Karnasurt Mt. Korobitsynite from Alluaiv forms prismatic, board-shaped or acicular crystals up to 2 cm long, sometimes twinned, typically combined in bunches, lattice-like intergrowths and chaotic clusters in cavities of aegirine-albite zone of this peralkaline pegmatite body. It is associated with elpidite, lorenzenite, shomiokite-(Y), epididymite, sphalerite, sidorenkite, rhodochrosite, trona *etc.* At Karnasurt, korobitsynite occurs as prismatic grains with natrolite, elpidite, labuntsovite, apophyllite, fluorite *etc.* The mineral is colourless, transparent. Korobitsynite from both localities usually forms oriented (epitactic) overgrowths on acicular elpidite crystals (Pekov *e.a.*, 1999).

Name: in the memory of Mikhail Fedorovich KOROBITSYN (1928–1996), Russian amateur mineralogist and mineral collector, for his significant contribution to the mineralogy of the Lovozero massif; Lovozero Geological-Exploration Party, Revda, Murmansk District.

IMA No.: 98-019. *TS:* FMM 89457, 89458.

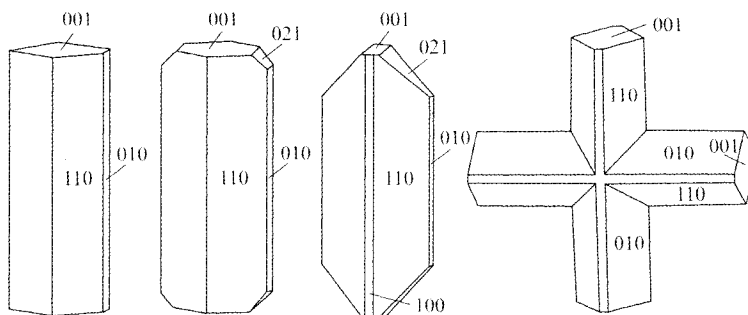

Korobitsynite crystals and twin from the Shomiokitovoye pegmatite, Alluaiv Mt., Lovozero (Pekov *e.a.*, 1999).



Complex twin and separate prismatic crystals of **kukharenkoite-(La)** on muscovite. Hilairitovoye pegmatite, Kirovskii mine, Kukisvumchorr Mt., Khibiny, Kola Peninsula, Russia. SEM image. Magnification: 200 \times . Specimen: A.S. Podlesnyi, photo: I.V. Pekov.

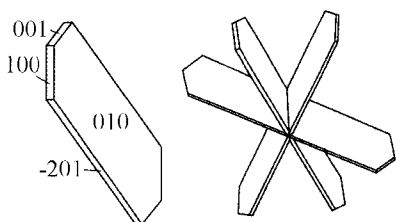

Kukharenkoite-(La) single crystal and trilling from the Hilairitovoye pegmatite, Kirovskii Mine, Khibiny (Pekov *e.a.*, 2003c).

Auto-epitactic overgrowth of crystals of Nb-poor variety of **kuzmenkoite-Mn** on a crystal of Nb-rich variety of the same mineral, with isometric calciohilairite crystals. Flora spur, Selsurt Mt., Lovozero, Kola Peninsula, Russia. SEM image. Magnification: 180 \times . Specimen and photo: I.V. Pekov.



KRIVOVICHEVITE, $\text{Pb}_3[\text{Al}(\text{OH})_6](\text{SO}_4)(\text{OH})$

Krivovichevite was discovered in the Pegmatite #47, Lepkhe-Nel'm Mt., Lovozero massif, Kola Peninsula, Russia. It occurs as colourless to grayish ice-like grains up to 1 cm with anglesite, cerussite, hydrocerussite, lanarkite and leadhillite inside corroded galena aggregates in the natrolite core of this peralkaline pegmatite body. Other associated minerals are orthoclase, aegirine, fluorapatite, kupletskite, mangan-neptunite, polyolithionite, monazite-(La), halloysite *etc.* Only preliminary data have been published for the present (Yakovenchuk *e.a.*, 2005).

Name: in honour of Sergey Vladimirovich KRIVOVICHEV (b. 1972), Russian crystallographer, Head of Department of Crystallography of Saint-Petersburg State University, for his contributions to the mineralogy of alkaline massifs and crystal chemistry of sulfates and lead compounds.

IMA No.: 2004-053. *TS:* KSC 6281.

KUDRIAVITE, $(\text{Cd,Pb})\text{Bi}_2\text{S}_4$

Kudriavite was discovered in the deposits of active fumaroles ($t \sim 400^\circ\text{C}$) in the southern part of the Rhenium fumarole field, Kudriaviy Volcano, Medvezh'ya (Bear's) Caldera, Iturup Island, Kurily Archipelago, Russia. The mineral occurs as dark grey, with a slight reddish tint and metallic luster, elongate slender platy crystals up to $0.02 \times 0.2 \times 0.4$ mm which form chaotic aggregates of several mm in pores and fissures of the fumarolic crust. Associated minerals are pyrite, wurtzite, greenockite and rehiite (Chaplygin *e.a.*, 2005).

Name: for the type locality.

IMA No.: 2003-011. *TS:* FMM 91655.

KUKHARENKOITE-(La), $\text{Ba}_2(\text{La,Ce})(\text{CO}_3)_3\text{F}$

Kukharenkoite-(La) was described as a new mineral from two peralkaline pegmatites at level +252 m of the Kirovskii underground mine, Kukisvumchorr Mt., Khibiny massif, Kola Peninsula, Russia. In the Hilairitovoye pegmatite (the holotype) it is associated with microcline, albite, calcite, nenadkevichite, hilairite, catapleiite, strontianite, donnayite-(Y), synchysite-(Ce), pyrite, *etc.*; in an unnamed pectolite-aegirine-microcline veinlet it was found with natrolite, calcite, vinnogradovite, Nd-dominant ewaldite and kukharenkoite-(Ce). Kukharenkoite-(La) forms colourless, white or pale green flattened-prismatic to acicular crystals up to 0.5 mm long, their snowflake-like interpenetration twins (trillings) with the $[-201]$ axis, crystal groups, open-worked intergrowths and brushes in cavities (Pekov *e.a.*, 2003c).

Name: La-dominant analogue of kukharenkoite-(Ce).

IMA No.: 2002-019. *TS:* FMM 91053.

KUZMENKOITE-Mn, $\text{K}_2(\text{Mn,Fe})(\text{Ti,Nb})_4[\text{Si}_4\text{O}_{12}]_2(\text{OH})_4 \cdot 5\text{H}_2\text{O}$

Labuntsovite group

Kuzmenkoite-Mn was discovered at Flora spur of Selsurt Mt., Lovozero massif, Kola Peninsula, Russia. It forms yellow, orange and light-brown well-shaped prismatic crystals up to 1.5 mm in cavities in an albitized porphyraceous eudialyte-murmanite lujavrite. It forms also pseudomorphs after lamellar murmanite crystals. Associated minerals are natrolite, labuntsovite-Mn, calciohilairite, carbonate-fluorapatite, aegirine, lorenzenite, *etc.* Kuzmenkoite-Mn is represented by several varieties different in contents of the impurities. Crystals of its chemically different varieties typically form oriented (parallel) intergrowths. The mineral was originally

photo 32

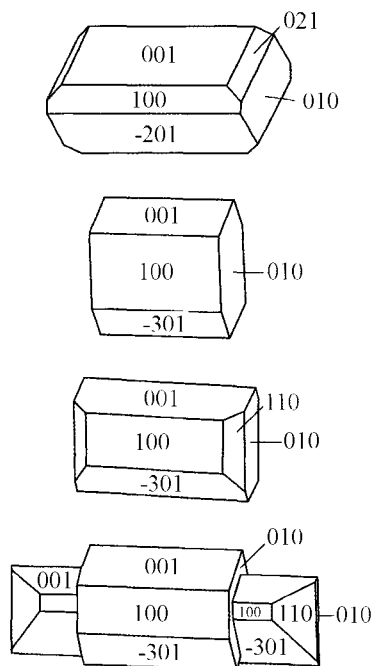

Kuzmenkoite-Mn single crystals and auto-epitactic overgrowth of a crystal of Nb-poor variety on a crystal of Nb-rich variety from the Flora spur of Selsurt Mt., Lovozero (Chukanov *e.a.*, 1999c).

Kyrgyzstanite crystal (Agakhanov *e.a.*, 2005a).

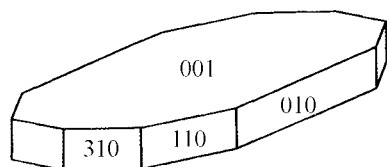

Group of divergent crystals of **kyrgyzstanite**. Kara-Tangi, Katran-Tau Mts., Osh District, Kyrgyzstan. SEM image. Specimen and photo: A.A. Agakhanov.

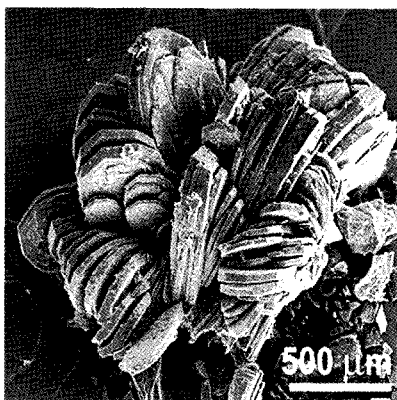

described as kuzmenkoite (Chukanov *e.a.*, 1999c) and later renamed to kuzmenkoite-Mn, according to IMA-accepted nomenclature for labuntsovite-group minerals (Chukanov *e.a.*, 2002b).

Name: in the memory of Maria Vasil'evna KUZ'MENKO (1918–1995), Russian geochemist and mineralogist who actively studied Lovozero massif and made significant contribution to the geochemistry and mineralogy of rare elements; Institute of Mineralogy, Geochemistry and Crystallography of Rare Elements (IMGRE), Moscow. Suffix-modifier -Mn reflects prevailing of Mn in the *D* site of the structure (Chukanov *e.a.*, 2002b).

IMA No.: 98-058. *TS:* FMM 89504.

KUZMENKOITE-Zn, $K_2Zn(Ti,Nb)_4(Si_4O_{12})_2(OH,0)_4 \cdot 6-8H_2O$

photo 33

Labuntsovite group

Kuzmenkoite-Zn was described as a new mineral from three peralkaline pegmatite bodies in Lovozero massif, Kola Peninsula, Russia: the Pegmatite #31 at Kedykverpakhk Mt., the Pegmatite #45 at Lepkhe-Nel'm Mt. and the Pegmatite #61 at Karnasurt Mt. At Kedykverpakhk, light brown aggregates of kuzmenkoite-Zn and kuzmenkoite-Mn form pseudomorphs after murmanite (up to several mm) associated with natrolite, microcline, albite, aegirine, eudialyte, lorenzenite, rhabdophane-(Ce) *etc.* At Lepkhe-Nel'm, colourless, white or pale brown long-prismatic to acicular crystals of kuzmenkoite-Zn up to 0.5 x 7 mm occur in cavities in aegirine-lamprophyllite-eudialyte aggregates, sometimes together with tsepinite-Na and fluorapatite. At Karnasurt, kuzmenkoite-Zn forms white, grayish or pinkish coarse prismatic crystals up to 0.3 x 0.5 x 3 mm in cavities of microcline-albite aggregates, with organovaite-Zn, organovaite-Mn, komarovite, strontioy-rochlore, natrolite, aegirine, elpidite, catapleite, yofortierite, taperssuatsiaite, epididymite, leifite, nontronite, quartz *etc.* (Chukanov *e.a.*, 2002d).

Name: Zn-dominant analogue of kuzmenkoite-Mn.

IMA No.: 2001-037. *TS:* FMM 90623.

KYRGYZSTANITE, $ZnAl_4(SO_4)(OH)_{12} \cdot 3H_2O$

Kyrgyzstanite, a Zn-dominant analogue of nickelalumite, was discovered at an abandoned mine on the Kara-Tangi uranium deposit, northern slope of the Katran-Tau Mts., foothills of the Turkestan Range, Osh District, Kyrgyzstan. It occurs in cavities and cracks in carbonaceous-siliceous shist as light blue or greenish crusts and radial spherulites, rarely isolated lamellar crystals up to 1 mm, with quartz, calcite, alumohydrocalcite and Zn-rich nickelalumite. Allophane and boehmite replace kyrgyzstanite (Agakhanov *e.a.*, 2005a).

Name: for the locality in Kyrgyzstan Republic.

IMA No.: 2004-024. *TS:* FMM 91648.

LABUNTSOVITE-Fe, $Na_2K_2FeTi_4[Si_4O_{12}]_2(0,OH)_4 \cdot 4-6H_2O$

photo 34

Labuntsovite group

Labuntsovite-Fe was described as a new mineral species at level +252 m of the Kirovskii underground mine, Kukisvumchorr Mt., Khibiny massif, Kola Peninsula, Russia. The holotype specimen was collected by A.S. Podlesnyi. It occurs in veinlets which consist of K-feldspar, natrolite and calcite, with pectolite, fluorite and aegirine. Labuntsovite-Fe forms bright orange grains up to 2 mm and their clusters up to 5 mm (Khomyakov *e.a.*, 2001b). Note that labuntsovite-Fe is relatively common mineral in peralkaline pegmatites and hydrothermalites at the

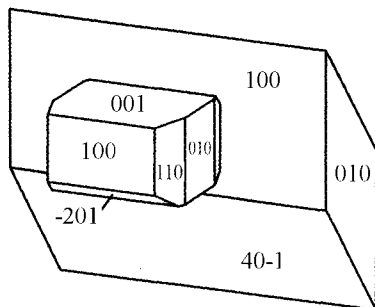

Parallel intergrowth of **labuntsovite-Fe** (small crystal) and **neskevaaraitite-Fe** from the Kirovskii Mine, Khibiny (after I.V. Pekov).

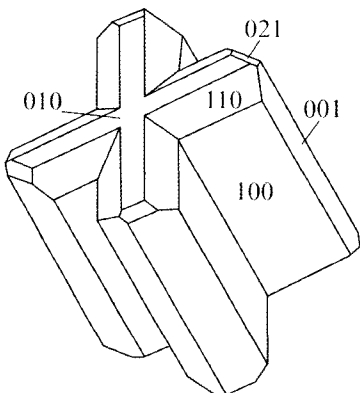

Labuntsovite-Mg twin from the Iron Mine, Kovdor (after I.V. Pekov).

Lemleinite-Ba crystal from the Kirovskii Mine, Khibiny (Chukanov *e.a.*, 2001b) (a), and overgrowth of isometric crystal of **lemleinite-Ba** on board-like crystal of kuzmenkoite-Mn from the Pegmatite #62, Karnasurt Mt., Lovozero (after I.V. Pekov).

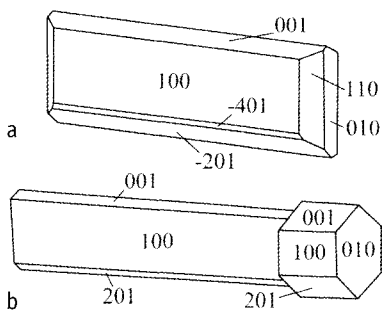

Kirovskii Mine and some other localities in Khibiny. In particular, it forms well-shaped crystals (Chukanov *e.a.*, 2003f).

Name: Fe-dominant (in the *D* site of the structure) member of the labuntsovite subgroup in the labuntsovite group (and Fe-dominant analogue of labuntsovite-Mn, an originally described labuntsovite: Chukanov *e.a.*, 2002b).

IMA No.: 98-051. *TS:* FMM 91285.

LABUNTSOVITE-Mg, $\text{Na}_2\text{K}_2\text{MgTi}_4[\text{Si}_4\text{O}_{12}]_2(\text{O,OH})_4 \cdot 4-6\text{H}_2\text{O}$ photo 35, 36

Labuntsovite group

Labuntsovite-Mg was described as a new mineral species at the open pit of the Iron Mine, Kovdor massif, Kola Peninsula, Russia. It occurs in cavities of dolomite carbonatite veins with catapleite, anatase, pyrite and calcite. The mineral forms prismatic crystals up to 3 mm and radial aggregates. Labuntsovite-Mg is colourless, white, pink or orange; polychromatic crystals are typical (Khomyakov *e.a.*, 2001b). *Name:* Mg-dominant (in the *D* site of the structure) member of the labuntsovite subgroup in the labuntsovite group (and Mg-dominant analogue of labuntsovite-Mn, an originally described labuntsovite: Chukanov *e.a.*, 2002b).

IMA No.: 98-050. *TS:* FMM 91287.

LABYRINTHITE, $(\text{Na,K,Sr})_{35}\text{Ca}_{12}\text{Fe}_3\text{Zr}_6\text{TiSi}_{51}\text{O}_{144}(\text{O,OH,H}_2\text{O})_9\text{Cl}_3$ *Eudialyte group*

Labyrinthite was discovered in the core of a borehole (depth 445) at Niorkpakh Mt., Khibiny massif, Kola Peninsula, Russia. It occurs as bright-pink roundish grains from 0.5 to 1 cm in size, with rims of zirsinalite, lovozerite and thermonatrite, in a peralkaline pegmatoid rock which consists of K-feldspar, sodalite, alkali amphibole, aegirine, pectolite, lamprophyllite, lomonosovite and villiaumite (Khomyakov *e.a.*, 2006b).

Name: from the Greek *labyrinthos* (labyrinth) that reflects unusually complicated crystal structure of the mineral.

IMA No.: 2002-065. *TS:* FMM 92096.

LEMMLEINITE-Ba, $\text{Na}_2\text{K}_2\text{Ba}_{1+x}\text{Ti}_4[\text{Si}_4\text{O}_{12}]_2(\text{O,OH})_4 \cdot 5\text{H}_2\text{O}$ photo 37

Labuntsovite group

Lemleinite-Ba was first described from three points of the Khibiny and Lovozero alkaline massifs, Kola Peninsula, Russia. The holotype specimen was collected by A.S. Podlesnyi at the Kirovskii underground mine, Kukisvumchorr Mt., Khibiny. Two co-type localities are the Pegmatite #62 in the north-eastern part of Karnasurt Mt. and Malyi Punkaruai Mt., both in the Lovozero massif. At the Kirovskii Mine, lemleinite-Ba was found with calcite and strontianite in cavities of a nepheline-aegirine-microcline pegmatite veinlet. It occurs as bright-orange to orange-red long-prismatic crystals up to 2 x 4 x 20 mm usually combined in sheaf-like groups. At Karnasurt, short-prismatic colourless to light coffee-coloured crystals (up to 1 mm) together with kuzmenkoite-Mn, tsepinite-K and aegirine form cellular pseudomorphs after lamellar crystals of murmanite (up to 0.5 x 6 x 10 cm) in microcline-aegirine zone of the pegmatite. Epitactic overgrowth of lemleinite-Ba on kuzmenkoite-Mn are typical for this locality. At Malyi Punkaruai, bright orange flattened prismatic crystals (up to 1 mm) of lemleinite-Ba occur in small cavities of an aegirine-microcline pegmatite (Chukanov *e.a.*, 2001b).

Name: Ba-dominant analogue of lemleinite-K.

IMA No.: 98-052. *TS:* FMM 90235 (Kirovskii Mine); KSC 4157 (Malyi Punkaruai).

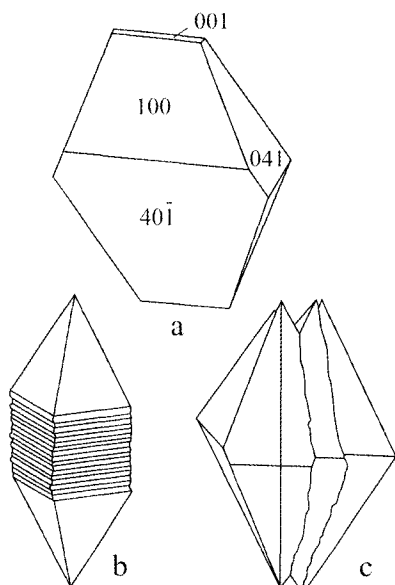

Lemmleinite-K crystals (a, b) and intergrowth (c).
a – after I.V. Pekov, b, c – from the paper by Khomyakov *e.a.*, 1999.

LEMMLEINITE-K, $\text{NaK}_2(\text{Ti,Nb})_2\text{Si}_4\text{O}_{12}(\text{OH})_2 \cdot 2\text{H}_2\text{O}$

photo 38

Labuntsovite group

Lemmleinite-K was described from several peralkaline pegmatites uncovered in the Koashva Quarry of the Vostochnyi (Eastern) Mine, Koashva Mt., Khibiny massif, Kola Peninsula, Russia. The holotype specimen was found in a cavity of the aegirine zone of a large pegmatite body. Lemmleinite-K was first discovered as colourless spindle-shaped crystals up to 1 mm, typically twinned, and their groups. Associated minerals are natrolite, pectolite, lamprophyllite, sitinakite, sazykinaite-(Y), catapleiite, rhabdophane-(Ce) *etc.* (Khomyakov *e.a.*, 1999). As it was found later, lemmleinite-K is widespread late mineral in these pegmatites. It forms also cream-coloured and pink flattened wedge-like and pseudo-dipyramidal crystals up to 5 mm, their clusters up to 1 cm and abundant complete pseudomorphs (up to 5 cm) after lomonosovite (Chukanov *e.a.*, 2003f). The mineral was originally described as lemmleinite (Khomyakov *e.a.*, 1999) and later renamed to lemmleinite-K according to IMA-accepted nomenclature for labuntsovite-group minerals (Chukanov *e.a.*, 2002b).

Name: in the memory of Georgii Glebovich LEMMLEIN (1901–1962), Russian crystallographer and mineralogist, a specialist in the field of crystal morphology and crystallogenesis; Institute of Crystallography of USSR Academy of Sciences, Moscow. Suffix-modifier -K reflects prevailing of K in the C site of the structure (Chukanov *e.a.*, 2002b).

IMA No.: 97-003. *TS:* FMM 89611.

LEPKHENELMITE-Zn, $\text{Ba}_2\text{Zn}(\text{Ti,Nb})_4[\text{Si}_4\text{O}_{12}]_2(\text{OH})_4 \cdot 7\text{H}_2\text{O}$ *Labuntsovite group*

Lepkhenelmit-Zn was discovered in the Pegmatite #45, Lepkhe-Nel'm Mt., Lovozero massif, Kola Peninsula, Russia. It occurs as light coffee-coloured coarse flattened-prismatic crystals up to 0.5 x 2.5 x 7 mm in cavities in lamprophyllite-eudialyte nests. Associated minerals are kuzmenkoite-Zn, tsepinit-Na, paratsepinit-Na, sphalerite, aegirine, natrolite, fluorapatite, barytolamprophyllite *etc.* (Pekov *e.a.*, 2004b).

Name: for the type locality. Suffix-modifier -Zn reflects prevailing of Zn in the D site of the structure (Chukanov *e.a.*, 2002b).

IMA No.: 2003-003. *TS:* FMM 91377.

LISITSYNITE, KBSi_2O_6

Lisitsynite was discovered at the Koashva Quarry of the Vostochnyi (Eastern) Mine, Koashva Mt., Khibiny massif, Kola Peninsula, Russia. It occurs in the core of a large peralkaline pegmatite, with microcline, pectolite, chkalovite, lomonosovite, aegirine, alkali amphibole and thermonatrite. Only specimen was found. It is a cluster of several corroded grains and coarse tabular crystals from 0.2 to 0.5 mm. The mineral is colourless, transparent (Khomyakov *e.a.*, 2000b).

Name: in honour of Apollon Efimovich LISITSYN (1928–1999), Russian geologist, a specialist in the geology, mineralogy and economic geology of boron deposits; All-Russian Research Institute of Mineral Resources (VIMS), Moscow.

IMA No.: 2000-008. *TS:* FMM 90287.

LITVINSKITE, $\text{Na}_2(\square,\text{Na,Mn})\text{ZrSi}_6\text{O}_{12}(\text{OH},\text{O})_6$

photo 39

Lovozerite group

Litvinskite was discovered in the Shkatulka pegmatite, Umbozero underground mine, Alluaiv Mt., Lovozero massif, Kola Peninsula, Russia. It occurs as abundant dark cherry-coloured isometric grains up to 7 cm and their clusters in the microcline-aegirine zone of this peralkaline pegmatite, with nepheline, sodalite, eudia-

lyte, lomonosovite, ussingite, mangan-neptunite *etc.* Terskite and gaidonnayite replace litvinskite (Pekov *e.a.*, 2000c). As it was found later, litvinskite is a product of hydrothermal alteration of kapustinite (Pekov *e.a.*, 2003e).

Name: in the memory of Galina Petrovna LITVINSKAYA (1920–1994), Russian crystallographer who was a brilliant teacher of crystallography; Geological Faculty of Moscow State University.

IMA No.: 99-017. *TS:* FMM 89656.

MAGNESIOTANTALITE, $(\text{Mg,Fe})(\text{Ta,Nb})_2\text{O}_6$ photo 40 *Columbite group*

Magnesiotantalite was discovered in the Quarry #4, Lipovka pegmatite field, vicinity of the Rezh City, Middle Urals, Russia. Aggregates of magnesiotantalite, ferrotantalite, ferrocolumbite and U-rich microlite form partial to complete pseudomorphs after manganotantalite crystals in plagioclase-calcite nests in the axial part of a desilicated granitic pegmatite vein cross-cutting serpentinite close to its contact with marble. Niobo-tantalate minerals are associated with dravite-uvite series tourmaline, chrysoberyl, phlogopite, magnesiohornblende-edenite series amphibole, Be-rich cordierite, phenakite, clinocllore *etc.* Magnesiotantalite occurs as opaque black flattened grains up to 0.4 mm and their clusters up to 0.7 mm (Pekov *e.a.*, 2003g).

Name: Mg-dominant analogue of ferrotantalite and manganotantalite.

IMA No.: 2002-018. *TS:* FMM 91050.

MAIKAINITE, $\text{Cu}_{20}(\text{Fe,Cu})_6\text{Mo}_2\text{Ge}_6\text{S}_{32}$ *Colusite group*

Maikainite was described as a new mineral from the Tsumeb Mine, Namibia (the holotype), and the Maikain gold deposit, Pavlodar District, Northern Kazakhstan. At Maikain, the mineral occurs as oval inclusions up to 0.045 mm, rarely octahedral or rhombododecahedral crystals, in sphalerite and bornite grains situated in barite aggregates. In reflected light, maikainite is light yellow to grayish-yellow (Spiridonov, 2003).

Name: for the first find at Maikain deposit.

IMA No.: 92-038. *TS:* FMM.

MAKAROCHKINITE, $\text{Ca}_2\text{Fe}_4^{2+}\text{Fe}^{3+}\text{TiSi}_4\text{BeAlO}_{20}$ photo 41 *Aenigmatite group*

Makarochkinite has a complicated history. It was first found by B.A. Makarochkin in the Pit #400 on the eastern slope of Ishkul Mt., Ilmeny Mts., South Urals, and visually determined as amphibole that mentioned in his unpublished geological report in 1955. Later the mineral was re-identified, again visually, as spinel by V.O. Polyakov in a specimen from B.A. Makarochkin collection. In 1986, it was repeatedly found at the same locality, studied and described as a new mineral makarochkinite (Polyakov *e.a.*, 1986). Its crystal structure was studied by O.V. Yakubovich *e.a.* (1990) that confirmed individuality of makarochkinite. However the mineral and its name were not considered for approval by the IMA CNMMN. In 1994, a new mineral høgtuvaite was described from Norway and its identity with makarochkinite was considered (Grauch *e.a.*, 1994). Later, F.C. Hawthorne and D.M.C. Humnicki (2002) contended that if Ti is fully ordered at a single M site as it is in aenigmatite, $\text{Na}_2\text{Fe}_5^{2+}\text{TiSi}_6\text{O}_{20}$, then makarochkinite would be the Ti-dominant analogue of høgtuvaite. The ordered distribution of Fe and Ti in makarochkinite was confirmed by a new crystal-structure study and, in result, makarochkinite, $\text{Ca}_2\text{Fe}_4^{2+}\text{Fe}^{3+}\text{TiSi}_4\text{BeAlO}_{20}$, was accepted by the IMA CNMMN as a mineral species different from høgtuvaite, $\text{Ca}_2\text{Fe}_3^{2+}\text{Fe}^{3+}\text{Si}_4\text{BeAlO}_{20}$ (Grew *e.a.*, 2005). Makarochkinite occurs as black grains to 5 cm in a granitic pegmatite. Associated minerals include feldspar, quartz, ferro-edenite, hastingsite, biotite, allanite-(Ce), samarskite-(Y), fergusonite-(Y), ferrocolumbite, ilmenite, magnetite, danalite, phenakite, gadolinite-(Y), zircon *etc.* (Polyakov *e.a.*, 1986; Grew *e.a.*, 2005).

Name: after Boris Aleksandrovich MAKAROCHKIN (1907–1988), Russian geologist and mineralogist, Head of Geological Survey of Ilmeny Natural Reserve, Miass, for more than 20 years, who first found the mineral.

IMA No.: 2002-009. *TS:* FMM 89351 (holotype), 89352; IR iz5662, 400Shch-6 (neotype); VGM 56028; National Museum of Natural History (Smithsonian Institute), Washington: NHMH-174051.

MALEEVITE, $\text{BaB}_2\text{Si}_2\text{O}_8$ *Danburite group*

Maleevite was found in the moraine of the Darai-Pioz Glacier, southern slope of the Alai Range, Tadjikistan. It was found in an alkaline pegmatite which mainly of quartz, microcline and aegirine. Other associated minerals are arfvedsonite, polyolithionite, reedmergnerite, kupletskite-Cs, hyalotekite, albite, dusmatovite, pyrochlore, tadjhikite, tienshanite, sogdianite, stillwellite-(Ce), leucosphenite, willemite, leucophanite, danburite, zektzerite, berezanskite, baotite and cappelenite-(Y). Maleevite occurs as colourless to white anhedral equant or tabular crystals and grains up to 2 mm. The mineral fluoresces bright blue in shortwave ultraviolet light (Pautov *e.a.*, 2004a).

Name: in honour of Mikhail Naidenov MALEEV (b. 1940), Bulgarian mineralogist, a specialist in crystal morphology, genesis of crystals and their aggregates and in mineral systematics, Director of *Earth and Man Museum*, Sofia.
IMA No.: 2002-027. *TS:* FMM 91072.

MALINKOITE, NaBSiO₄

Malinkoite was first described from two points of the Lovozero massif, Kola Peninsula, Russia: the Pegmatite #60 at the right bank of the Second Eastern Stream, northern slope of Karnasurt Mt., and dumps of the Umbozero underground mine, Alluaiv Mt. The holotype specimen from the Pegmatite #60 is rosette-like cluster (3 mm in diameter) of white with cream-pinkish tint wedge-shaped crystals in cavity of ussingite; associated minerals are steenstrupine-(Ce), manganonordite-(Ce), chkalovite, gerasimovskite *etc.* At Alluaiv, malinkoite occurs as pale pink and greenish-blue spherulites up to 2 mm in diameter associated with leifite and opal in cavities of an albitized peralkaline pegmatoid rock (Khomyakov *e.a.*, 2000b).

Name: in honour of Svetlana Vyacheslavovna MALINKO (1927–2002), Russian mineralogist, a specialist in the mineralogy of boron deposits, a discoverer of numerous boron minerals; All-Russian Research Institute of Mineral Resources (VIMS), Moscow.
IMA No.: 2000-009. *TS:* FMM 90288, 90289.

MANGANONAUJAKASITE, Na₆(Mn,Fe)Al₄Si₈O₂₆

Manganonaujakasite was discovered in the core of a borehole (depth about 250 m) at Alluaiv Mt., Lovozero massif, Kola Peninsula, Russia. It is found in lovozerite-lomonosovite lujavrite, with K,Na-feldspar, nepheline, sodalite, lovozerite, lomonosovite, analcime, aegirine, villiaumite, lamprophyllite, vuonnemite, manaksite, umbozerite, *etc.* Manganonaujakasite occurs as isolated bright sky-blue grains up to 1 mm, rarely to 5 mm (Khomyakov *e.a.*, 2000a).

Name: Mn-dominant analogue of naujakasite.
IMA No.: 99-031. *TS:* FMM 90284, 90285.

MANGANONORDITE-(Ce), Na₃SrCeMnSi₆O₁₇

photo 42

Nordite group

Manganonordite-(Ce) was first described in three points of the Lovozero alkaline massif, Kola Peninsula, Russia. The holotype specimen was found in the ussingite zone of the Pegmatite #60 at the right bank of the Second Eastern Stream, northern slope of Karnasurt Mt. At this locality, manganonordite-(Ce) forms spherulites and rosettes to 2.5 cm in diameter composed of tabular crystals 1 x 1 x 0.2 cm in size. Associated minerals include steenstrupine-(Ce), umbozerite, murmanite, chkalovite, sphalerite, epistolite, gerasimovskite *etc.* In adits at Karnasurt and Kedykverpakhk Mountains, rosettes of tabular manganonordite-(Ce) crystals to 5 mm were found in selvages of several ussingite veinlets with natrolite, sodalite, vuonnemite, steenstrupine-(Ce), phosinaite-(Ce), mangan-neptunite, natisite, villiaumite, *etc.* Manganonordite-(Ce) is typically colourless, transparent, but yellow or brown varieties are also noted (Pekov *e.a.*, 1998a).

Name: Mn- and Ce-dominant member of the nordite group.
IMA No.: 97-007. *TS:* FMM 88828.

MEGAKALSILITE, KAlSiO₄

Megakalsilite was discovered in a specimen from the Koashva Quarry of the Vostochnyi (Eastern) Mine, Koashva Mt., Khibiny massif, Kola Peninsula, Russia. It occurs in the core of a large peralkaline pegmatite, with aegirine, pectolite, microcline, sodalite, natrolite, lomonosovite, chkalovite, lovozerite, cancrinite, umbite, lemmleinite-K, natrite, vitusite-(Ce), fluorcaphite, nacaphite, bonshtedtite *etc.* Megakalsilite was found as a transparent colourless corroded, anhedral grain 3 mm across. It fluoresces pale whitish-green in ultraviolet light (Khomyakov *e.a.*, 2002).

Name: by adding the prefix *mega* (from the Greek μέγας, meaning great) to the name *kalsilite*, which is the most common modification of KAlSiO₄ in nature, emphasizing the chemical identity of the two minerals and a fact that unit cell volume of megakalsilite is a twelve times larger than one of kalsilite.

IMA No.: 2001-008. *TS:* FMM 91294.

MENIAYLOVITE, Ca₄AlSi(SO₄)F₁₃·12H₂O

Meniaylovite was discovered at the First and Second cinder cones, Northern Breakthrough of the Tolbachik Main Fracture Eruption (1975–1976), Tolbachik Volcano, Kamchatka, Russia. It is a product of the alteration of volcanic rocks under fumarole gases. Meniaylovite forms colourless or white octahedral and cubo-octahedral crystals up to 0.2 mm and yellowish-white crusts. It

is associated with malladrite, hieratite(?), ralstonite, anhydrite, gypsum and hematite. Meniaylovite is a mineral related to chukhrovites (Vergasova *e.a.*, 2004b).

Name: in the memory of Igor Aleksandrovich MENIAYLOV (1937–1993), Russian volcanologist who made significant contribution to the geochemistry of exhalations of the Tolbachik Main Fracture Eruption; Institute of Volcanology of Far East Branch of Russian Academy of Sciences, Petropavlovsk-Kamchatskii.

IMA No.: 2002-050. *TS:* PMM kn.p.3205.

MENSHIKOVITE, Pd₃Ni₂As₃

Menshikovite was first described as a new mineral from sulfide ores related to two mafic-ultramafic layered complexes in Russia. Co-type localities are the Vostok PGE deposit, eastern part of the Lukkulaivaara complex, Northern Karelia, and the Chiney complex, Kodar-Udokan area, Chita District, South Siberia. Also its find at the Oktyabr'skoe PGE-Cu-Ni deposit, Talnakh city, Norilsk area, Krasnoyarsk Territory, Siberia, Russia, has been reported in original description. At Lukkulaivaara, menshikovite was found as anhedral grains up to 0.2 mm with chalcopyrite, pentlandite, the minerals of sobolevskite – kotulskite and violarite – greigite series, merenskyite *etc.* At Chiney, it occurs as grains up to 0.1 mm with maucherite, cobaltite, chalcopyrite, sperrylite, hollingworthite, paolovite, isomertieite *etc.* (Barkov *e.a.*, 2002).

Name: in honour of Yuriy Pavlovich MEN'SHIKOV (b. 1934), Russian mineralogist, a specialist in X-ray powder diffraction study of minerals and in the mineralogy of Khibiny massif; Geological Institute of Kola Science Center of Russian Academy of Sciences, Apatity.

IMA No.: 93-057. *TS:* FMM.

MIASSITE, Rh₁₇S₁₅

Miassite was found in a small unnamed placer deposit at the upper Miass River, near Zlatoust, South Urals, Russia. It forms roundish inclusions, up to 0.07 x 0.1 mm, in isoferroplatinum. In reflected light, the mineral is gray with bluish tint. Associated minerals are cuprorhodsite, ferrorhodsite, vasilite, cooperite, bowieite, keithconite and bornite (Britvin *e.a.*, 2001).

Name: after the type locality.

IMA No.: 97-029. *TS:* PU 1/19220; PMM kn.p.3073/2.

MIDDENDORFITE, K₃Na₂Mn₅Si₁₂(OH)₃₆·2H₂O

Middendorffite was discovered in the Hilairitovoye pegmatite, level +252 m of the Kirovskii underground mine, Kukisvumchorr Mt., Khibiny massif, Kola Peninsula, Russia. The specimens were collected by A.S. Podlesnyi. Middendorffite occurs as dark-orange to bright-orange coarse rhomb-like lamellar or tabular crystals up to 0.1 x 0.2 x 0.4 mm combined in worm-like and fan-like aggregates up to 1 mm, in cavities or embedded in calcite. Other associated minerals are microcline, sodalite, cancrisilite, aegirine, natrolite, fluorite, narsarsukite, labuntsovite-Mn, mangan-neptunite, donnayite, *etc.* (Pekov *e.a.*, 2006b).

Name: in the memory of Aleksandr Fedorovich von MIDDENDORF (1815–1894), an outstanding German-Russian scientist-naturalist, Academician of Russian Academy of Sciences and Honorary member of Russian Mineralogical Society, who completed first mineralogical studies in Khibiny alkaline massif in 1840.

IMA No.: 2005-028. *TS:* FMM 92113.

Worm-like aggregates of **middendorffite** formed by its lamellar crystals. Hilairitovoye pegmatite, Kirovskii mine, Kukisvumchorr Mt., Khibiny, Kola Peninsula, Russia.

SEM image. Magnification: a – 200 \times , b – 1500 \times .

Specimen: A.S. Podlesnyi, photo: I.V. Pekov.

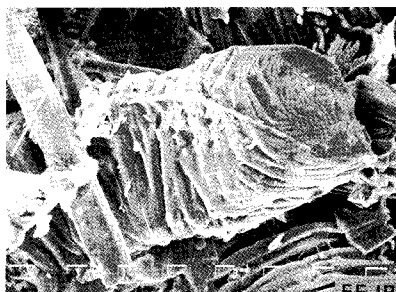

MITRYAEVAITE, $\text{Al}_{10}[(\text{PO}_4)_{8.7}(\text{SO}_3\text{OH})_{1.3}]_{\Sigma 10}\text{AlF}_3 \cdot 30\text{H}_2\text{O}$

Mitryaevaite was found at several localities, in black shales of the Cambrian vanadium-bearing Kurumsak geological formation in South Kazakhstan. It was described from the Balasauskandyk (the holotype) and Kurumsak vanadium deposits at North-Western Karatau Range and from Dzhebagly (Zhabagly) Mts. It occurs as white to colourless fine powdery coatings on walls of fractures in the rocks or as fine subparallel and complex dendritic veins, rarely nodules up to 8 mm. Associated minerals are minyulite, crandallite, gorseixite, wavellite, variscite, evansite, aluminite, meta-aluminite, kaolinite, gypsum and hewettite (Ankinovich *e.a.*, 1997).

Name: in honour of Nonna Mikhailovna MITRYAEVA (b. 1920), Russian-born mineralogist, for her contributions to the mineralogy of Kazakhstan; Institute of Geological Sciences, Alma-Ata.

IMA No.: 91-035. *TS:* PU 1/19055; Geological Museum of Satpaev Institute of Geological Sciences, Almaty: GM-IGS-24/1270.

MOGOVIDITE, $\text{Na}_9(\text{Ca},\text{Na})_6\text{Ca}_6(\text{Fe}^{3+},\text{Fe}^{2+})_2\text{Zr}_3\text{Si}_{25}\text{O}_{72}(\text{CO}_3)(\text{OH},\text{H}_2\text{O})_4$ photo 43 *Eudialyte group*

Mogovidite was first described in two points of the Kovdor massif, Kola Peninsula, Russia: on the level 115 m in the north part of the open pit of the Iron Mine (the holotype) and in dumps of the open pit of the Mica Mine. Mogovidite from Iron Mine was found in single thin (1 cm) nepheline-pectolite veinlet cross-cutting ijolite, with aegirine-augite, titanite, humite, andradite, scolecite and calcite. It forms red-brown grains up to 2 cm. The mineral from Mica Mine occurs as brownish-red tabular crystals and grains up to several mm in Ca-rich alkaline pegmatite with cancrinite, hedenbergite, pectolite, thomsonite-Ca and calcite (Chukanov *e.a.*, 2005).

Name: for Mogo-Vid Mountain near the discovery locality.

IMA No.: 2004-040. *TS:* FMM 91780, 92106.

MOSKVINITE-(Y), $\text{Na}_2\text{K}(\text{Y},\text{REE})[\text{Si}_6\text{O}_{15}]$

Moskvinit-(Y) was found in the moraine of the Darai-Pioz Glacier, southern slope of the Alai Range, Tadjikistan. It occurs in specific alkaline pegmatite mainly consisting of reedmergnerite (about 80 vol.%) with Mn-rich pectolite, Pb-rich eudialyte-group mineral, microcline, polyolithionite, aegirine, albite, telyushenkoite, kentbrooksit, shibkovite, nordite-(Ce), leucophanite, hyalotekite, calcite and quartz. Moskvinit-(Y) forms isolated colourless grains up to 2 mm. It fluoresces violet in both shortwave and longwave diaspans of ultraviolet light (Agakhanov *e.a.*, 2003b).

Name: in the memory of Aleksandr Veniaminovich MOSKVIN (1897–1974), Russian geologist who actively worked in Central Asia and, in particular, first distinguished Darai-Pioz as individual alkaline massif; Pamirs-Tadjik Geological Expedition, Dushanbe.

IMA No.: 2002-031. *TS:* FMM 91073.

MUTNOVSKITE, $\text{Pb}_2\text{AsS}_3(\text{I},\text{Cl},\text{Br})$

Mutnovskite was discovered in active high-temperature fumaroles in the crater of the Mutnovsky Volcano, Kamchatka, Russia. It occurs as ruby-coloured to brown-red short prismatic crystals up to 0.1 mm associated in cavities with Pb,Bi halogen-sulfosalts, kudriavite, greenockite, pyrite, anhydrite and cristobalite (Zelenski *e.a.*, 2006).

Name: for the type locality.

IMA No.: 2004-032. *TS:* Museum "C.L. Garavelli", Dipartimento Geomineralogico, Università degli Studi di Bari (Italy): #7nm-V28.

NABALAMPROPHYLLITE, $\text{Ba}(\text{Na},\text{Ba})\{\text{Na}_3\text{Ti}[\text{Ti}_2\text{O}_2\text{Si}_4\text{O}_{14}](\text{OH},\text{F})_2\}$ photo 44

Nabalamprophyllite was first described from two alkaline-ultrabasic massifs in Russia: from the Inagli massif, 30 km northwest of the city of Aldan, South Yakutia (Republic of Sakha-Yakutia), Siberia (the holotype), and from the open pit of the Mica Mine, Kovdor massif, Kola Peninsula. At Inagli, it was found in a peralkaline pegmatite with albite, orthoclase, alkali pyroxene, batisite, innelite, neptunite, leucosphenite, strontiumapatite *etc.* At Kovdor, it occurs in peralkaline pegmatite veins with orthoclase, aegirine-diopside, cancrinite, nepheline, pectolite, natrolite, thomsonite-Ca, eudialyte, feklichevite, lorenzenite, lueshite, tacharanite, calcite *etc.* Nabalamprophyllite forms coarse translucent prismatic yellow to yellow-brown crystals up to 10 cm at Inagli and up to 1 cm at Kovdor (Chukanov *e.a.*, 2004b).

Name: reflects close relationship to lamprophyllite and ordered distribution of species-forming cations Na and Ba in interlayer sites of the structure.

IMA No.: 2001-060. *TS:* Geological Museum of Institute of Geology and Geophysics of Siberian Branch of Russian Academy of Sciences, Novosibirsk: XIII-274/1 (Inagli); FMM 90837, 90843 (Kovdor).

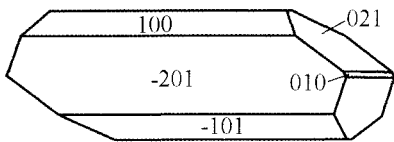

Neskevaaraite-Fe crystal from the Kirovskii Mine, Khibiny (Chukanov *e.a.*, 2003e).

NEPSKOEITE, $\text{Mg}_4\text{Cl}(\text{OH})_7 \cdot 2\text{H}_2\text{O}$

Nepskoeite was discovered at Nepskoe potassium salt deposit near the city of Ust'-Kut, Irkutsk District, Eastern Siberia, Russia. It was found in the cores of several boreholes (700–800 m depth), in halite-anhydrite rock with fluoborite and pyrrhotite. Nepskoeite forms isolated fibrous spherulites from 0.5 to 1.5 mm in diameter. The mineral is colourless with yellowish tint (Apollonov, 1998).

Name: for the type locality.

IMA No.: 96-016. *TS:* FMM 89864.

NESKEVAARAITE-Fe, $\text{NaK}_3\text{Fe}(\text{Ti,Nb})_4(\text{Si}_4\text{O}_{12})_2(\text{OH})_4 \cdot 6\text{H}_2\text{O}$

photo 45

Labuntsovite group

Neskevaaraite-Fe was first described from two localities, in the cores of boreholes in both cases. The holotype specimen was found at the Neskevara (Neskevaara) Hill, Vuoriyarvi massif, North Karelia (near the boundary of Karelia with Kola Peninsula), Russia. The co-type locality is level +172 m of the Kirovskii underground mine, Kukisvumchorr Mt., Khibiny massif, Kola Peninsula, Russia. In Vuoriyarvi, it occurs as coarse brown translucent prismatic crystals up to 6 mm long in hydrothermally altered carbonatite, with dolomite, calcite, phlogopite, fluorapatite, pyrite, pyrrhotite, chalcocopyrite, serpentine and nenadkevichite. In Khibiny, neskevaaraite-Fe was found by A.S. Podlesnyi in a vein which consists of K-feldspar and calcite. It forms dull yellow-brown long-prismatic crystals up to 1 x 4 x 18 mm in cavities, with donnayite, or embedded in calcite. Parallel intergrowths of neskevaaraite-Fe with bright red labuntsovite-Fe were observed at this locality (Chukanov *e.a.*, 2003e).

Name: for the type locality.

IMA No.: 2002-007. *TS:* FMM 91048.

NICKELPHOSPHIDE, $(\text{Ni,Fe})_3\text{P}$

Nickelphosphide, a Ni-dominant analogue of schreibersite, was described as a new mineral in several iron meteorites including carbonaceous chondrite Efremovka (found in Pavlodar District, North Kazakhstan) and Ni-rich ataxite Onello found in 1997 in the alluvium of the Bol'shoy Dolguchan River, a tributary of the Onello River, Aldan River basin, South Yakutia (Republic of Sakha-Yakutia), Russia. In the latter, nickelphosphide occurs as elongate grains up to 0.1 mm together with taenite, kamacite, schreibersite and allabogdanite (initially erroneously identified as "barringerite") (Britvin *e.a.*, 1999a).

Name: after chemical composition: nickel phosphide.

IMA No.: 98-023. *TS:* PMM M-8/1 (Butler meteorite); PU 1/19218 (Butler meteorite).

NIKSERGIEVITE, $(\text{Ba,Ca})_2\text{Al}_3(\text{Si,Al})_4\text{O}_{10}(\text{CO}_3)(\text{OH})_6 \cdot n\text{H}_2\text{O}$

Niksergievite was found on level no. 12 (+400 m) of the Tekeli Pb-Zn underground mine, Djungarsky Alatau Mts., 40 km S.E.E. of the city of Taldy-Kurgan, South Kazakhstan. The mineral occurs as white, with a light greenish tint, curved plates 3–5 mm in size forming rosette-like aggregates up to 5 cm across. Associated minerals are calcite, quartz, dolomite, celsian, sphalerite, pyrite, barite and montmorillonite (Saburov *e.a.*, 2005).

Name: in the memory of Nikolai Grigorievich SERGIEV (1901–1960), Russian-born geologist, for his contributions to the geology of Kazakhstan; Geographical Faculty of Kazakh State University, Alma-Ata.

IMA No.: 2002-036. *TS:* FMM 91378; PU 1/19217; Geological Museum of Institute of Geological Sciences, Almaty.

NOVGORODOVAITE, $\text{Ca}_2(\text{C}_2\text{O}_4)\text{Cl}_2 \cdot 2\text{H}_2\text{O}$

Novgorodovaites was discovered in the core of a borehole (depth 850–900 m) at the Chelkar salt dome, Western Kazakhstan. It was identified in specimens nos. 69819 and 69820 deposited in Fersman Mineralogical Museum of Russian Academy of Sciences. They were acquired in 1960s from Mining Museum of Leningrad Mining Institute and from V.V. Lobanova correspondingly. Novgorodovaites forms aggregates of colourless transparent grains up to 7 mm associated with anhydrite, gypsum, halite, bischofite, magnesite and hilgardite in an evaporite rock (Chukanov *e.a.*, 2001a).

Name: in honour of Margarita Ivanovna NOVGORODOVA (b. 1938), Russian mineralogist, a specialist in the mineralogy and genesis of native elements, Director of Fersman Mineralogical Museum of Russian Academy of Sciences, Moscow.

IMA No.: 2000-039. *TS:* FMM 69820.

ORGANOVAITE-Mn, $\text{K}_2\text{Mn}(\text{Nb,Ti})_4[\text{Si}_4\text{O}_{12}]_2(\text{OH})_4 \cdot 6\text{H}_2\text{O}$

photo 46

Labuntsovite group

Organovaites-Mn was described from two points of the Lovozero massif, Kola Peninsula, Russia: the Pegmatite #61 in the north-eastern part of Karnasurt Mt. (the holotype) and Flora spur of Selsurt Mt. At Karnasurt, organovaites-Mn forms pink or brown fine-grained (grains <0.01 mm) pseudomorphs after lamellar vuonnemite crystals (up to 4 cm) in hydrothermally altered zones of a peralkaline pegmatite, with microcline, aegirine, natrolite, albite, rancieite, sauconite, organovaites-Zn, epididymite *etc.* Coarse prismatic white or pinkish crystals of organovaites-Mn (up to 0.3 x 3 mm) were found with kuzmenkoite-Mn and elpidite in cavities of the same pegmatite. At Flora, the mineral occurs as yellow-brown short-prismatic crystals up to 0.5 mm in cavities in albitized porphyraceous eudialyte-murmanite lujavrite, with vuoriyarvite-K, kuzmenkoite-Mn, calciohilairite, natrolite *etc.* (Chukanov *e.a.*, 2001d).

Name: in honour of Natalia Ivanovna ORGANOVA (b. 1929), Russian crystallographer, the author of basic works on the crystal chemistry of labuntsovite-group minerals; Institute of Geology of Ore Deposits, Petrography, Mineralogy, and Geochemistry of Russian Academy of Sciences (IGEM), Moscow. Suffix-modifier-Mn reflects prevailing of Mn in the *D* site of the structure.

IMA No.: 2000-031. *TS:* FMM 90044.

ORGANOVAITE-Zn, $\text{K}_2\text{Zn}(\text{Nb,Ti})_4(\text{Si}_4\text{O}_{12})_2(\text{O,OH})_4 \cdot 6\text{H}_2\text{O}$

photo 47

Labuntsovite group

Organovaites-Zn was discovered in the Pegmatite #61, Karnasurt Mt., Lovozero massif, Kola Peninsula, Russia. It occurs as white to pinkish-brown coarse prismatic crystals up to 0.5 x 0.5 x 4 mm and massive pink to brown pseudomorphs after lamellar vuonnemite crystals up to 0.2 x 2 x 3 cm. Associated minerals are natrolite, microcline, albite, aegirine, organovaites-Mn, beryllite, komarovite, elpidite, yofortierite, nontronite, rancieite *etc.* (Pekov *e.a.*, 2002b).

Name: Zn-dominant analogue of organovaites-Mn.

IMA No.: 2001-006. *TS:* FMM 90371, 90405.

Organovaites-Zn crystal (after I.V. Pekov).

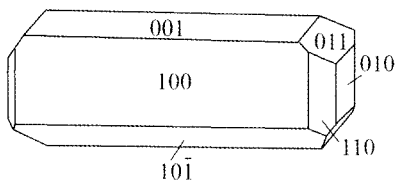
**PAKHOMOVSKYITE**, $\text{Co}_3(\text{PO}_4)_2 \cdot 8\text{H}_2\text{O}$ *Vivianite group*

Pakhomovskiyte was discovered in specimens from the open pit of the Iron Mine, Kovdor massif, Kola Peninsula, Russia. It occurs in cracks in dolomite carbonatite as groups of bright pink spherulites up to 0.1 mm in diameter. This dolomite carbonatite also contains magnetite, phlogopite and pyrrhotite; bobierrite, bakhchisaraitsevite, kovdorskite, juonniite, norsethite and pyrite occur in its cavities (Yakovenchuk *e.a.*, 2006).

Name: in honour of Yakov Alekseevich PAKHOMOVSKY (b. 1948), Russian mineralogist, a specialist in physical methods of study of minerals, for his great contribution to the mineralogy of Kola Peninsula; Geological Institute of Kola Science Center of Russian Academy of Sciences, Apatity.

IMA No.: 2004-021. *TS:* KSC 6265.

PALLADODYMITE, $(\text{Pd,Rh})_2\text{As}$

Palladodymite was discovered in a small unnamed placer deposit at the upper Miass River, near Zlatoust, South Urals, Russia. It forms inclusions up to 0.03 x 0.07 mm in native ruthenium. In reflected light, the mineral is brownish-gray with bluish tint. Associated minerals are isoferroplatinum, tulameenite, cherepanovite, sperrylite, irarsite, hongshiite *etc.* (Britvin *e.a.*, 1999b). *Name:* derived from *palladium* and the Greek $\delta\mu\omicron\varsigma$ (twin): the mineral is the Pd-dominant analogue of rhodarsenide.

IMA No.: 97-028. *TS:* PMM r3076.

PARAKUZMENKOITE-Fe, $(\text{K,Ba})_2\text{Fe}(\text{Ti,Nb})_4[\text{Si}_4\text{O}_{12}]_2(\text{O,OH})_4 \cdot 7\text{H}_2\text{O}$

Labuntsovite group

Parakuzmenkoite-Fe was discovered in an unnamed peralkaline pegmatite body on the north-eastern slope of Kedykverpakhk Mt., Lovozero massif, Kola Peninsula, Russia. The holotype specimen was found by E.I. Semenov in 1950s. The mineral occurs as orange to orange-red coarse prismatic crystals up to 0.3 x 1 mm associated with aegirine, microcline, lorenzenite, eudialyte, sodalite, natrolite, elpidite, rancieite and halloysite (Chukanov *e.a.*, 2001c).

Name: Fe-dominant (in the D site of the structure) mineral related to kuzmenkoites; prefix para- reflects doubled, in comparison with kuzmenkoite subgroup members, the c parameter of its unit cell, in accordance with IMA-accepted nomenclature for labuntsovite-group minerals (Chukanov *e.a.*, 2002b).

IMA No.: 2001-007. *TS:* FMM 91037.

PARATSEPINITE-Ba, $(\text{Ba,Na,K})_{3-x}(\text{Ti,Nb})_2[\text{Si}_4\text{O}_{12}](\text{O,OH})_2 \cdot 3-4\text{H}_2\text{O}$

Labuntsovite group

Paratsepinitite-Ba was discovered in the Pegmatite #45, Lepkhe-Nel'm Mt., Lovozero massif, Kola Peninsula, Russia. It forms light brown long-prismatic crystals up to 5 mm long, associated in cavities with tsepinitite-Na, kuzmenkoite-Zn, Nb-rich titanite, aegirine, eudialyte, lamprophyllite, lorenzenite, natrolite, vinogradovite, tundrite-(Ce) *etc.* (Chukanov *e.a.*, 2003d).

Name: Ba-dominant mineral related to tsepinites; prefix para- reflects doubled, in comparison with tsepinitite subgroup members, c parameter of its unit cell, in accordance with IMA-accepted nomenclature for labuntsovite-group minerals (Chukanov *e.a.*, 2002b).

IMA No.: 2002-006. *TS:* FMM 91045.

PARATSEPINITE-Na, $(\text{Na,Sr,K,Ca})_{2-x}(\text{Ti,Nb})_2[\text{Si}_4\text{O}_{12}](\text{O,OH})_2 \cdot 2\text{H}_2\text{O}$

Labuntsovite group

Paratsepinitite-Na was found at Khibinpakhkchorr Mt., Khibiny massif, Kola Peninsula, Russia. It occurs in cavities of a peralkaline pegmatite, with analcime, natrolite, tsepinitite-Na, catapleite, apophyllite, fluorite, epididymite, sphalerite, *etc.* Its colourless prismatic crystals epitaxially overgrow on orange long-prismatic labuntsovite-Mn crystals. Only preliminary data were published (Organova *e.a.*, 2004).

Name: Na-dominant analogue of paratsepinitite-Ba (and the mineral dimorphous with tsepinitite-Na which has doubled c parameter of the unit cell).

IMA No.: 2003-008. *TS:* FMM 91051, 91052.

PARAVINOGRADOVITE, $(\text{Na}, \square)_2[(\text{Ti}^{4+}, \text{Fe}^{3+})_4\{\text{Si}_2\text{O}_6\}_2\{\text{Si}_3\text{AlO}_{10}\}(\text{OH})_4] \cdot \text{H}_2\text{O}$

photo 48

Paravinogradovite was described from the Svintsovyi Stream, the eastern spur of Kukisvumchorr Mt., Khibiny massif, Kola Peninsula, Russia. It occurs in cavities in albitized zone of a peralkaline pegmatite near fenitized xenolith of a gneiss situated in foyaites. Paravinogradovite forms colourless to white fan-shaped aggregates of board-like to acicular crystals up to 1 cm long. It weakly fluoresces yellow-green in ultraviolet light. Associated minerals are K-feldspar, albite, aegirine, natrolite, zircon, ilmenite, carbonate-fluorapatite, ancylite-(Ce), nordstrandite, fluorite *etc.* (Khomyakov *e.a.*, 2003b).

Name: reflects close chemical and structural relationship to vinogradovite.

IMA No.: 2002-033. *TS:* FMM 91297.

PAUTOVITE, CsFe_2S_3

Rasvumite group

Pautovite, a Cs-analogue of rasvumite and picotpaulite, was discovered in the Palitra pegmatite, Kedykverpakhk Mt., Lovozero massif, Kola Peninsula, Russia. Associated minerals are belovite-(Ce), villiamite, aegirine, ussingite, natrosilite, microcline,

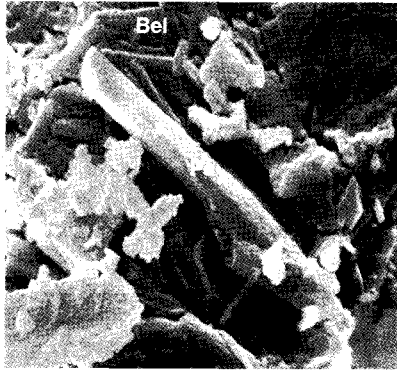

Prismatic crystal (0.03 mm long) of **pautovite** (Pa) on belovite-(Ce) aggregate (Bel). Palitra pegmatite, Kedykverpakhk Mt., Lovozero, Kola Peninsula, Russia. SEM image. Specimen and photo: I.V. Pekov.

sodalite, potassicarfvedsonite, serandite, nordite-(Ce), ferronordite-(Ce), bornemanite, vuonnemite, lomonosovite, vitusite-(Ce), phosinaite-(Ce), barytolamprophyllite, mangan-neptunite, manaksite, chkalovite, kapustinite, kazakovite, steenstrupine-(Ce), thorosteenstrupine, bario-oligite, nalipoite, sphalerite, lollingite, wurtzite, bartonite, chlorbartonite, zakharovite *etc.* Pautovite occurs as dark steel-grey, with strong metallic luster, coarse prismatic to acicular crystals up to 0.015 x 0.12 mm, typically forming subparallel overgrowths on belovite-(Ce) in cavities of a peralkaline pegmatite (Pekov *e.a.*, 2005a).

Name: in honour of Leonid Anatol'evich PAUTOV (b. 1958), Russian mineralogist, for his significant contributions to the study of minerals by physical methods, the mineralogy of alkaline pegmatites and the mineralogy of cesium; Fersman Mineralogical Museum of Russian Academy of Sciences, Moscow.

IMA No.: 2004-005. *TS:* FMM 92109.

PEKOVITE, $\text{SrB}_2\text{Si}_2\text{O}_8$

Danburite group

Pekovite was found in the moraine of the Darai-Pioz Glacier, southern slope of the Alai Range, Tadjikistan. It was found in blocky quartz lump, probably a fragment of the core of an alkaline pegmatite. Pekovite occurs as colourless anhedral equant grains up to 0.2 mm, commonly intergrown with pectolite, quartz, aegirine and Sr-rich fluorite. Other minerals of this assemblage are polyolithionite, microcline, reedmergnerite, stillwellite-(Ce), leucosphenite, sogdianite, turkestanite, galena, calcite, kapitsaite-(Y), neptunite, sugilite, zeravshanite, pyrochlore, tadjhikite, baratovite, bismuth, sphalerite, fluorapatite, fluorapophyllite, eudialyte-group members *etc.* (Pautov *e.a.*, 2004a).

Name: in honour of Igor Viktorovich PEKOV (b. 1967), Russian mineralogist, a specialist in the mineralogy of alkaline complexes, mineralogy of rare elements and history of Russian mineralogy; Department of Mineralogy of Moscow State University.

IMA No.: 2003-035. *TS:* FMM 92047.

PERTSEVITE, $\text{Mg}_2\text{B}_3\text{O}_3\text{F}$

Pertsevite was discovered in a single thin section of a boron ore from an unnamed locality near the mouth of Kebirin'ya creek, a northern (right) tributary of Dogdo River, Yana River basin, Tas-Khayakhtakh Ridge in the Chersky Mountain System, Eastern Verkhoyan'e, Polar Yakutia (Republic of Sakha-Yakutia), Siberia, Russia. The specimen was found by N.N. Pertsev in 1964. Pertsevite forms 5–10 vol.% of a kotoite marble. Associated minerals are calcite, kotoite, forsterite, clinohumite, spinel, ludwigite, alumino-magnesiophulsite, lollingite, szaibelyite and brucite. Pertsevite occurs as colourless anhedral crystals and grains up to 0.15 mm (Schreyer *e.a.*, 2003).

Name: in honour of Nikolay Nikolaevich PERTSEV (b. 1930), Russian mineralogist and petrologist, an investigator of boron minerals and deposits, who had collected the kotoite marble and dedicated the thin section studied; Institute of Geology of Ore Deposits, Petrography, Mineralogy, and Geochemistry of Russian Academy of Sciences (IGEM), Moscow.

IMA No.: 2002-030. *TS:* Mineralogical Collection of Institut für Geologie, Mineralogie und Geophysik, Ruhr-Universität Bochum, Germany: 25164.

PHOSPHOINNELITE, $\text{Ba}_4\text{Na}_3\text{Ti}_3\text{Si}_4\text{O}_{14}(\text{PO}_4\text{SO}_4)_2(\text{O,F})_3$

photo 48

Phosphoinnelite was discovered in the open pit of the Mica Mine, Kovdor massif, Kola Peninsula, Russia. It occurs in a peralkaline pegmatite vein cross-cutting cal-

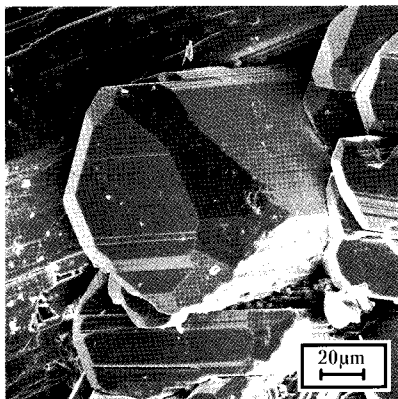

Podlesnoite crystals.
Kirovskii mine, Kukisvumchorr Mt., Khibiny, Kola Peninsula, Russia. SEM image.
Specimen: A.S. Podlesnyi, photo: I.V. Pekov.

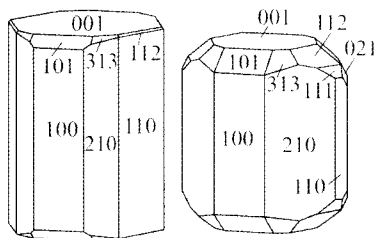

Podlesnoite crystals
(Pekov *e.a.*, in press[e]).

cite carbonatite. Associated minerals are cancrinite (partially altered to thomsonite-Ca), orthoclase, aegirine-augite, pectolite, magnesio-arfvedsonite, golyshchite, fluorapatite, phlogopite, calcite *etc.* It forms yellow-brown to brown lath-like crystals up to 0.2 x 1 x 6 mm typically combined in bunch-, sheaf- and rosette-like aggregates (Pekov *e.a.*, 2006c).

Name: analogue of innelite with P > S.

IMA No.: 2005-022. *TS:* FMM 91918.

PODLESNOITE, $BaCa_2(CO_3)_2F_2$

photo 50

Podlesnoite was discovered at the Kirovskii underground mine, Kukisvumchorr Mt., Khibiny massif, Kola Peninsula, Russia, in specimens collected by A.S. Podlesnyi. It occurs in cavities of a lensoid natrolite body situated in urtite. Associated minerals are aegirine, phlogopite, ilmenite, calcite, fluorite, barytocalcite, fluorapatite, burbankite, lorenzenite and lemmleinite-K. Two varieties of podlesnoite different in morphology are observed. Well-shaped aqua-transparent colourless prismatic crystals up to 1 x 1 x 4 mm (variety I) are isolated or form clusters up to 1.5 x 2 cm. Snow-white acicular to the fibrous variety (variety II) forms dense radial spherulites up to 5 mm in diameter. Usually surface of these spherulites is completely covered by the crystals of a variety I; such "combined" spherulites up to 8 mm in diameter were found. A variety I fluoresces pinkish-orange in shortwave ultraviolet light, a variety II shows weak blue-lilac fluorescence in shortwave and very weak lilac-blue fluorescence in longwave ultraviolet light (Pekov *e.a.*, in press[e]).

Name: in honour of Aleksandr Semenovich PODLESNYI (b. 1948), Russian amateur mineralogist and prominent mineral collector, an owner of the best systematic collection of minerals from the Kirovskii Mine, who 25 years actively collaborates with professional mineralogists and has provided for study a self-collected material which became the holotype or cotype specimens of 14 new mineral species; Kirovskii Mine, JSC "Apatit", Kirovsk.

IMA No.: 2006-033. *TS:* FMM r3460/1.

POLKANOVITE, $Rh_{12}As_7$

Polkanovite was found in a small unnamed placer deposit at the upper Miass River, near Zlatoust, South Urals, Russia. It forms irregular inclusions, up to 0.045 x 0.14 mm, in native ruthenium. In reflected light, polkanovite is brownish-gray. Associated minerals are isoferroplatinum, tulameenite, cherepanovite, speryllite, irarsite, palladodymite *etc.* (Britvin *e.a.*, 1998).

Name: in honour of Yuriy Aleksandrovich POLKANOV (b. 1935), Ukrainian mineralogist, Academician of Academy of Technical Sciences of Ukraine: Simferopol'.

IMA No.: 97-030. *TS:* PU 1/19219; PMM 3073/1.

POLYAKOVITE-(Ce), $(REE,Ca)_4(Mg,Fe^{2+})(Cr^{3+},Fe^{3+})_2(Ti,Nb)_2Si_4O_{22}$ photo 51

Polyakovite-(Ce) was discovered in the Pit #97, the eastern edge of the North-Ilmen swamp, Ilmeny Mts., South Urals, Russia. It was first found in 1976 by V.F. Zhdanov and briefly described as "chromium-magnesium analogue of chevkinite" (Zhdanov *e.a.*, 1986). Later it was studied in detail and approved by the IMA CNMMN as polyakovite-(Ce). It occurs in a carbonatite vein with calcite, dolomite, phlogopite, fluororichterite, forsterite, chondrodite, clinohumite, monazite-(Ce), fergusonite-(Y), aeschynite-(Ce) and Cr-bearing varieties of spinel and davidite-(Ce). Polyakovite-(Ce) form black anhedral equant grains up to 2.5 cm and, rarely, prismatic crystals up to 2 mm (Popov *e.a.*, 2001).

Polyakovite-(Ce) crystal (Popov *e.a.*, 2001).

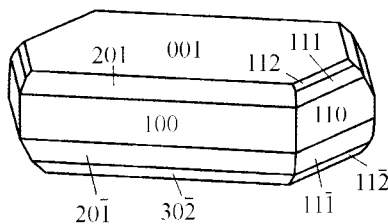

Name: in the memory of Vladislav Olegovich POLYAKOV (1950–1993), Russian mineralogist, a specialist in the mineralogy of the Urals, for his great contribution to the mineralogy of the Ilmeny Mts.; in particular, he has initiated the study of this mineral; Institute of Mineralogy of Urals Branch of Russian Academy of Sciences, Miass.

IMA No.: 98-029. *TS:* IR iz6751, iz6752 (donated by V.O. Polyakov).

POTASSICARFVEDSONITE, $\text{KNa}_2\text{Fe}^{2+}_4\text{Fe}^{3+}\text{Si}_6\text{O}_{22}(\text{OH})_2$ photo 52 *Amphibole group*

Potassicarfvedsonite was described as a new mineral species from three alkaline complexes. The holotype specimen was found in the "Pegmatite Valley", the small stream in the valley being the lowermost tributary to the Lilleelv, in the Kangerluarsuk area, southern part of the Ilimaussaq complex, South Greenland. Co-type localities are at Kola Peninsula, Russia: the Palitra pegmatite, Kedykverpakhk Mt., Lovozero massif, and the Hilairitovoye pegmatite, level +252 m, Kirovskii underground mine, Kukisvumchorr Mt., Khibiny massif. The type material from Ilimaussaq and Lovozero was collected by I.V. Pekov, from Khibiny – by A.S. Podlesnyi. In the Palitra pegmatite, potassicarfvedsonite forms dark blue-green to blue-gray acicular crystals up to 0.1 x 2 mm usually combined in bunches and hedgehog-like clusters up to 4 mm; it also occurs as massive nodules up to 1.5 cm across which consist of acicular to fibrous crystals. Potassicarfvedsonite aggregates are situated in cavities in ussingite nests and inside altered crystals of manaksite. Associated minerals are serandite, aegirine, microcline, lomonosovite, vuonnemite, villiaumite, natrolite, chkalovite, phosinaite-(Ce), sphalerite, natrosilite, nalipoite *etc.* In the peripheral zone of the Hilairitovoye pegmatite, potassicarfvedsonite forms black prismatic crystals up to 1 x 5 cm with abundant inclusions of green aegirine needles. Associated minerals are microcline, nepheline, sodalite, lamprophyllite, eudialyte, fersmanite, rinkite, titanite, fluorapatite, natrolite *etc.* Note that potassicarfvedsonite is an "old new mineral": analyses of "arfvedsonite" with $\text{K} > 0.50 \text{ apfu}$ from several alkaline complexes were earlier published (Pekov *e.a.*, 2004c).

Name: K-dominant analogue of arfvedsonite.

IMA No.: 2003-043. *TS:* FMM 91652 (Ilimaussaq), 91653 (Lovozero).

POTASSIC-CHLOROPARGASITE, $\text{KCa}_2(\text{Mg,Fe})_4\text{Al}[\text{Si}_6\text{Al}_2\text{O}_{22}](\text{Cl,OH})_2$ *Amphibole group*

Potassic-chloropargasite was discovered at Elgoras Mt., Sal'nye Tundry, Kola Peninsula, Russia. The mineral occurs as black grains up to 0.5 mm associated with chlorapatite, almandine, diopside, enstatite, Cl-rich biotite, potassicpargasite, marialite and plagioclase in a metasomatically altered zone in basic granulite rock (Chukanov *e.a.*, 2002b).

Name: K- and Cl-dominant analogue of pargasite.

IMA No.: 2001-036. *TS:* FMM 91040, 91041.

POTASSIC-FERRISADANAGAITE, $(\text{K,Na})\text{Ca}_2(\text{Fe}^{2+},\text{Mg})_3(\text{Fe}^{3+},\text{Al})_2[\text{Si}_5\text{Al}_3\text{O}_{22}](\text{OH})_2$ *Amphibole group*

Potassic-ferrisadanagaite was described as a new mineral species from the Ilmeny Mts., South Urals, Russia. It is a rock-forming mineral of some varieties of plagiostenite, alkali syenite and related nepheline syenite. It forms black short-prismatic crystals up to 5 mm, rarely to 2 cm, associated with K,Na-feldspar, oligoclase, nepheline, ugrandite garnet, fluorapatite, allanite-(Ce) and titanite (Bazhenov *e.a.*, 1999).

Name: Fe^{3+} - and K-dominant analogue of sadanagaite.

IMA No.: 97-035. *TS:* FMM 91650; IR iz8660.

POTASSIC-MAGNESIOHASTINGSITE, $(\text{K,Na})\text{Ca}_2(\text{Mg,Fe}^{2+})_4(\text{Fe}^{3+},\text{Al,Ti})[\text{Si}_6\text{Al}_2\text{O}_{22}](\text{OH,Cl})_2$ *Amphibole group*

Potassic-magnesiohastingsite was described as a new mineral species from the Osinovyi Mys (Cape), east coast of the Bol'shoy Ishkul' Lake, Ilmeny Mts., South Urals, Russia. It is a rock-forming mineral of biotite-amphibole gabbro. The mineral occurs as black short-prismatic grains (5–20 mm) associated with plagioclase (labradorite), Ba-rich biotite, magnetite, ilmenite, titanite, zircon *etc.* (Korinevskii, Korinevskii, 2006).

Name: K-dominant analogue of magnesiohastingsite.

IMA No.: 2004-027. *TS:* FMM 91650.

PSEUDOSINHALITE, $\text{Mg}_2\text{Al}_3\text{B}_2\text{O}_9(\text{OH})$

Pseudosinhalite was discovered in the core of a borehole at the Tayozhnoye Fe-B deposit, Aldan Region, South Yakutia (Republic of Sakha-Yakutia), Russia. It is found in a calciphyre which consists of calcite, dolomite, forsterite and serpentine, with clinohumite, ludwigite, spinel, warwickite, suanite, szaibelyite, brucite, sinhalite and hydrotalcite. Pseudosinhalite occurs as colourless grains (<0.1 mm) and veinlets replacing sinhalite (Schreyer *e.a.*, 1998).

Name: denotes optical, structural and chemical relationship to sinhalite.

IMA No.: 97-014. *TS:* Mineralogical Collection of Institut für Geologie, Mineralogie und Geophysik, Ruhr-Universität Bochum, Germany.

RASLAKITE, $\text{Na}_{15}\text{Ca}_3\text{Fe}_3(\text{Na,Zr})_3\text{Zr}_3(\text{Si,Nb})(\text{Si}_{25}\text{O}_{73})(\text{OH,H}_2\text{O})_3(\text{Cl,OH})$ photo 53 *Eudialyte group*

Raslakite was discovered in dumps of an adit at the Kedykverpakhk area of the Karnasurt underground mine, Kedykverpakhk Mt., Lovozero massif, Kola Peninsula, Russia. It was found in single lump of a peralkaline pegmatite which consists of microcline, aegirine, nepheline and lamprophyllite, with kazakovite and fluorcaphite. Raslakite occurs as brownish-red isometric grains up to 3 cm surrounded by terskite rim (Chukanov *e.a.*, 2003c).

Name: after two picturesque Raslak glacial cirques situated near Kedykverpakhk Mt.

IMA No.: 2002-067. *TS:* FMM 91295, 91296.

RASTSVETAEVITE, $\text{Na}_{27}\text{K}_8\text{Ca}_{12}\text{Fe}_3\text{Zr}_6\text{Si}_4[\text{Si}_3\text{O}_9]_4[\text{Si}_9\text{O}_{27}]_4(\text{O,OH,H}_2\text{O})_6\text{Cl}_2$ *Eudialyte group*

Rastsvetaevite was described as a new mineral from an adit at level +530 m, Rasvumchorr underground mine, Rasvumchorr Mt., Khibiny massif, Kola Peninsula, Russia. In original description, also its finds in other points in Khibiny massif have been listed: drill-cores in the Vuonnemiok River valley and at Mountains Niorkpakhk, Eveslogchorr and Rasvumchorr and dumps of underground mines at Mountains Rasvumchorr, Kukisvumchorr and Yukspor. The holotype specimen from the Rasvumchorr underground mine was collected in a large peralkaline pegmatite which mainly consists of nepheline, sodalite, K-feldspar, aegirine-diopside, alkali amphibole and aenigmatite. Rastsvetaevite occurs as reddish-pink grains up to 2 mm and their clusters up to 2 cm typically partially replaced by zirsinalite and lovozerite. Associated minerals are aegirine, lamprophyllite, lomonosovite, shcherbakovite, delhayelite, pectolite, natrolite, villiaumite, natrite, thermonatrite, nacaphite, phosinaite-(Ce), olympite, sidorenkite, rasvumite, djerfisherite *etc.* (Khomyakov *e.a.*, 2006a).

Name: in honour of Ramiza Kerarovna RASTSVETAEVA (b. 1936), Russian crystallographer who studied crystal structures of many minerals including numerous eudialyte-group members; Institute of Crystallography of Russian Academy of Sciences, Moscow.

IMA No.: 2000-028. *TS:* FMM 91292.

REMONDITE-(La), $\text{Na}_3(\text{La,Ce,Ca})_3(\text{CO}_3)_5$ *Burbankite group*

Remondite-(La) was discovered at the Koashva Quarry of the Vostochnyi (Eastern) Mine, Koashva Mt., Khibiny massif, Kola Peninsula, Russia. It was found in cavities in the aegirine zone of a small peralkaline pegmatite, with microcline, cancrisilite, sodalite, villiaumite, natrolite, pectolite, lomonosovite, lamprophyllite, sazykinaite-(Y), vitusite-(Ce), fluorcaphite, thermonatrite *etc.* Remondite-(La) occurs as bright orange-yellow coarse-prismatic "crystals" (up to 0.5 x 0.8 x 2 mm) which consist of chaotic aggregate of tiny (to 0.005 mm) irregular grains (Pekov *e.a.*, 2000a).

Name: La-dominant analogue of remondite-(Ce).

IMA No.: 99-006. *TS:* FMM 89694.

RHENIITE, ReS_2 photo 54

Rheniite was described as a new mineral from the Rhenium fumarole field, Kudriavyy Volcano, Medvezh'ya (Bear's) Caldera, Iturup Island, Kurily Archipelago, Russia. The mineral was discovered at this locality in 1992 (natural ReS_2 was firstly found at Usu Volcano, Hokkaido, Japan, earlier: Bernard, Dumortier, 1986) and was reported in literature without IMA-approved name (as "natural ReS_2 ", "rhenium disulfide", "kurilite" *etc.*) many times. Rheniite occurs in the deposits of active fumaroles ($t = 380\text{--}560^\circ\text{C}$) as rich crusts covering areas up to 10 x 10 cm^2 and aggregates filling cracks up to 5 mm width. They consist of thin-lamellar pseudo-hexagonal rhomb-like and band-shaped crystals up to 4 mm, usually curved. The mineral is visually similar to related molybdenite: its colour is silvery, luster is strong metallic. However, unlike molybdenite, thin crystals of rheniite are semi-transparent, with brown-red inner reflexes. Associated minerals are magnetite, corundum, wollastonite, andradite-grossular garnet, wurtzite, greenockite, cadmoindite, halite *etc.* (Znamenskii *e.a.*, 2005).

Name: reflects rhenium content.

IMA No.: 99-004. *TS:* FMM 88231, 90818, 90824, 91249.

RUDEKOKITE, $\text{Sr}_3\text{Al}_{3.5}\text{Si}_{3.5}\text{O}_{10}(\text{OH}_{7.5}\text{O}_{0.5})\text{Cl}_2\cdot\text{H}_2\text{O}$ photo 55

Rudenkoite was discovered in a specimen from the Emel'dzhak phlogopite deposit, Aldan River basin, South Yakutia (Republic of Sakha-Yakutia), Russia. It occurs in cavities in a pseudomorph of prehnite after scapolite from prehnitized metasomatic pyroxene-scapolite rock. Other associated minerals are calcite, spinel, apatite and diopside. Rudenkoite forms pearly-white spheroidal fibrous aggregates up to 7 mm (Chukanov *e.a.*, 2004a).

Name: in the memory of Sergey Aleksandrovich RUDENKO (1917–1992), Russian mineralogist, a specialist in the mineralogy of granitic pegmatites; Leningrad (now Saint-Petersburg) Mining Institute.

IMA No.: 2003-060. *TS:* FMM 91871.

SEIDITE-(Ce), $\text{Na}_4(\text{Ce,Sr})_2\text{TiSi}_8\text{O}_{18}(\text{O,OH,F})_4(\text{OH})_2 \cdot 5\text{H}_2\text{O}$ photo 56

Seidite-(Ce) was found in the Yubileinaya pegmatite, Karnasurt Mt., Lovozero massif, Kola Peninsula, Russia. It forms pale-yellow, pinkish-yellow or cream-coloured spherulites up to 1 cm in diameter, which consist of needles or fibres, and their clusters. Visually, the mineral is very similar to laplandite-(Ce). Seidite-(Ce) occurs in cavernous pinkish natrolite together with belovite-(Ce), vitusite-(Ce), sazhinite-(Ce), steenstrupine-(Ce), mangan-neptunite, serandite, sphalerite *etc.* (Khomyakov *e.a.*, 1998). In some earlier publications, seidite-(Ce) was mentioned as "mineral M31" (Khomyakov, 1995).

Name: after the Seidozero Lake situated in the central part of the Lovozero Mountains.

IMA No.: 93-029. *TS:* FMM 90192, 90193, 90194.

SENKEVICHITE, $\text{CsKNaCa}_2\text{TiO}[\text{Si}_7\text{O}_{18}(\text{OH})]$

Senkevichite, a K,Cs ordered analogue of tinaksite, was discovered in the moraine of the Darai-Pioz Glacier, southern slope of the Alai Range, Tadjikistan. It was found in blocky quartz lump, probably a fragment of the core of an alkaline pegmatite, in quartz-pectolite aggregates with aegirine, fluorite, polyolithionite, neptunite, hyalotekite, pekovite, leucosphenite *etc.* It forms clusters of colourless transparent board-shaped grains up to 1 mm (Agakhanov *e.a.*, 2005b).

Name: in the memory of Yuriy Alekseevich SENKEVICH (1937–2003), Russian geographer, traveller and military doctor who studied the behaviour of a human organism under extreme conditions; he was also well-known TV reporter and journalist specialized in geography.

IMA No.: 2004-017. *TS:* FMM 92107.

SHIBKOVITE, $\text{K}(\text{Ca,Mn,Na})_2(\text{K}_{2-x}\square_x)_2\text{Zn}_3\text{Si}_{12}\text{O}_{30}$ photo 57

Osumilite group

Shibkovite was discovered in the moraine of the Darai-Pioz Glacier, southern slope of the Alai Range, Tadjikistan. It was first found in a lump of an alkaline pegmatite which consists of microcline, quartz, reedmergnerite, aegirine, polyolithionite, sogdianite, albite, pectolite, eudialyte-group minerals, pyrochlore and turkestanite. Shibkovite forms isolated isometric grains up to 0.5 mm among quartz and microcline. The mineral is colourless or white, with strong red fluorescence in shortwave ultraviolet light (Pautov *e.a.*, 1998). Note that larger (up to 1–2 cm) grains of shibkovite were found later at the same locality, in reedmergnerite aggregates.

Name: in the memory of geologists Viktor Sergeevich SHIBKOV (1926–1992) and his son Nikolay Viktorovich SHIBKOV (1951–1991) who actively studied the geology of Central Asia. V.S. Shibkov worked in Kyrgyzian State Geological Administration, Frunze, N.V. Shibkov worked in Sarydjaz Geological Expedition, Sarydjaz, both – Kyrgyzstan.

IMA No.: 97-018. *TS:* FMM 89493.

SHIROKSHINITE, $\text{K}(\text{NaMg}_2)\text{Si}_4\text{O}_{10}\text{F}_2$ photo 58

Mica group

Shirokshinite was discovered at level +252 m of the Kirovskii underground mine, Kukisvumchorr Mt., Khibiny massif, Kola Peninsula, Russia. It occurs in small cavities of a peralkaline pegmatite. Shirokshinite forms coarse hexagonal prismatic crystals up to

Skeletal crystal of **shirokshinite**.
Kirovskii mine, Kukisvumchorr Mt., Khibiny,
Kola Peninsula, Russia.
SEM image. Magnification: 100×.
Specimen: A.S. Podlesnyi, photo: I.V. Pekov.



1 x 2.5 mm and their sheaf-like clusters up to 2.5 mm. Snowflake- and lattice-like skeletal crystals formed by needle- or ruler-shaped subindividuals up to 0.06 mm long are typical. Associated minerals are microcline, kupletskite, aegirine, natrolite, lorenzenite, calcite, remondite-(Ce), donnayite-(Y), mckelveyite-(Y) and galena (Pekov *e.a.*, 2003b).

Name: in the memory of Nikolay Vasil'evich SHIROKSHIN (1809–?), Russian geologist, a Captain of the Russian Mining Corps, who was the first researcher of Khibiny alkaline massif; he visited Khibiny for field observations in summer 1834 and published the first data on its geology, petrology and geomorphology.

IMA No.: 2001-063. *TS:* FMM 91046.

SOROSITE, Cu(Sn,Sb)

Sorosite was described as a new mineral from the Baimka Au-PGE placer deposit, near Baimka River, Bol'shoy Anyuy River area, Western Chukotka, Russia. It occurs as brittle subhedral to anhedral hexagonal crystals up to 0.4 mm included in Sb-bearing native tin, with stistaite, herzenbergite, lead and cassiterite. In reflected light, sorosite is white with weak pinkish tint (Barkov *e.a.*, 1998).

Name: in honour of George SOROS (b. 1930), well-known American financier, in recognition of his important support to science (the IFS, established by G. Soros, has been a great help to scientists in republics of the former Soviet Union) and efforts to promote open societies throughout the world.

IMA No.: 94-017. *TS:* PMM 2083/1.

TATYANAITE, (Pt,Pd,Cu)₉Cu₃Sn₄

Tatyanaite, a Pt-dominant analogue of taimyrite, was discovered at Oktyabr'skoye PGE-Cu-Ni deposit, Talnakh city, Norilsk area, Krasnoyarsk Territory, Siberia, Russia. It is found as platy grains up to 0.2 mm and their elongated aggregates up to 1 mm in massive sulfide (pyrrhotite-pentlandite-chalcocopyrite) ore with galena, magnetite, sperrylite, Pt-rich taimyrite, atokite-rustenburgite series minerals, paolovite, froodite, maslovite, Au-Ag alloy *etc.* In reflected light, tatyanaite is pink with lilac tint (Barkov *e.a.*, 2000b).

Name: in honour of Tat'yana L'vovna EVSTIGNEEVA (b. 1945), Russian mineralogist and crystal chemist, who studied many years PGE minerals and various ore minerals of Norilsk area; Institute of Geology of Ore Deposits, Petrography, Mineralogy, and Geochemistry of Russian Academy of Sciences (IGEM), Moscow.

IMA No.: 95-049. *TS:* Museum of University of Hamburg.

TELYUSHENKOITE, CsNa₆[Be₂Al₃Si₁₅O₃₉F₂]

Telyushenkoite, a Cs-dominant analogue of leifite, was discovered in a specimen from the moraine of the Darai-Pioz Glacier, southern slope of the Alai Range, Tadjikistan. It occurs in a specific alkaline pegmatitic rock which consists mainly (85–90 vol.%) of reedmergerite. Other associated minerals are microcline, pectolite, nordite-(Ce), leucophanite, hyalotekite, kentbrooksite, polyolithionite and albite. Telyushenkoite forms colourless to white equant grains up to 2 cm in interstices of reedmergerite aggregates. The mineral weakly fluoresces violet in both shortwave and longwave diapsans of ultraviolet light (Agakhanov *e.a.*, 2003a).

Name: in the memory of Tamara Matveevna TELYUSHENKO (1930–1997), a petrographer who made significant contribution to the geology of Central Asia, and an enthusiastic teacher of young geologists; Turkmenian Research Geological-Prospecting Institute (TurkmenNIGRI), Ashkhabad.

IMA No.: 2001-012. *TS:* FMM 90435.

THOMSONITE-Sr, (Sr,Ca)₂Na[Al₅Si₅O₂₀]₆·7H₂O

Zeolite group

Thomsonite-Sr was discovered in two points of the Khibiny massif, Kola Peninsula, Russia. The holotype specimen was found at small spur of Rasvumchorr Mt. near Yuksporlak Pass. Co-type locality is dumps of a tunnel built in the end of 1980s at Yukspor Mt., near the mouth of Hackman Valley. At Rasvumchorr, the mineral occurs in veinlets up to 5 mm thick cross-cutting the natrolite core of a peralkaline pegmatite. The veinlets consist of natrolite, thomsonite-Ca, thomsonite-Sr, chabazite-Ca and chabazite-K. Associated minerals in the pegmatite are K-feldspar, aegirine, astrophyllite, fluorapatite, lorenzenite, shcherbakovite, cafetite, magnetite, pyrophanite, aeschynite-(Ce), phillipsite-Ca *etc.* Thomsonite-Sr forms colourless perfect prismatic (bar-shaped) crystals up to 0.2 x 1 mm in cavities of veinlets. Each crystal epitactically overgrows a needle-shaped natrolite crystal (*c*-axes of both zeolites are parallel). At Yukspor, thomsonite-Sr was found in cavities of a veinlet up to 2 cm thick which cross-cut urtite. This veinlet mainly consists of calcite, thomsonite-Ca and tobermorite. Fluorapophyllite, barite and thaumasite occur in cavities together with aqua-transparent colourless well-shaped prismatic thomsonite crystals up to 0.5 x 1 x 3 mm. These crystals are con-

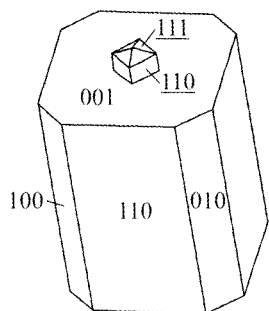

Epitactic overgrowth of **thomsonite-Sr** on natrolite from Kuamdespakhk Mt., Lovozero (after I.V. Pekov).



Thomsonite-Sr crystals. Rasvumchorr Mt., Khibiny, Kola Peninsula, Russia. SEM image. Magnification: 150 \times . Specimen and photo: I.V. Pekov.

Epitactic overgrowth of **tsepinite-K** on nenadkevichite. Hilairitovoye pegmatite, Kirovskii mine, Kukisvumchorr Mt., Khibiny, Kola Peninsula, Russia. SEM image. Magnification: 500 \times . Specimen: A.S. Podlesnyi, photo: I.V. Pekov.

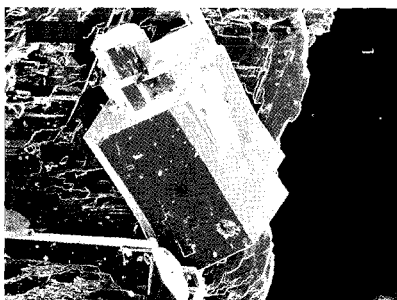

centrically zoned: zones of thomsonite-Ca and thomsonite-Sr (up to 0.02 mm thick each) rhythmically alternate (Pekov *e.a.*, 2001d).

Name: Sr-dominant analogue of thomsonite-Ca (the discovery of thomsonite-Sr caused a necessity of the establishment of the thomsonite series instead of a mineral species thomsonite and, correspondingly, renaming of "usual" thomsonite to thomsonite-Ca).

IMA No.: 2000-025. **TS:** FMM 91034.

TSEPINITE-Ca, $(Ca,K,Na, \square)_2(Ti,Nb)_2(Si_4O_{12})(OH,O)_2 \cdot 4H_2O$

photo 59

Labuntsovite group

Tsepinite-Ca was described from the abandoned Lovchorrite underground mine, upper part of Hackman Valley, Yukspor Mt., Khibiny massif, Kola Peninsula, Russia. It was found in the hydrothermally altered zone of a peralkaline pegmatite. Associated minerals are microcline, aegirine, natrolite, kentbrooksit, kupletskite, lamprophyllite, fluorapatite, catapleite, ancylite-(Ce), ancylite-(La), fluorapophyllite, leucophanite, lorenzenite, vinogradovite, titanite, tainiolite, calcite and chabazite-Ca. Tsepinite-Ca occurs in cavities after leached prismatic rinkite crystals. The mineral forms colourless, white or pale brownish coarse long-prismatic to acicular crystals up to 0.2 x 0.6 x 5 mm, usually split and combine in sheaf-like clusters up to 2 x 6 mm or chaotic open-worked aggregates up to 1 cm (Pekov *e.a.*, 2003a).

Name: Ca-dominant analogue of tsepinite-Na.

IMA No.: 2002-019. **TS:** FMM 91054.

TSEPINITE-K, $(K,Ba,Na)_{3-x}(Ti,Nb)_2[Si_4O_{12}](OH,O)_2 \cdot 3-4H_2O$

photo 60

Labuntsovite group

Tsepinite-K was described as a new mineral from three peralkaline pegmatites in the Lovozero and Khibiny massifs, Kola Peninsula, Russia. The holotype specimen was found in the Pegmatite #62, Karnasurt Mt., Lovozero massif, the cotype specimens – in the Hilairitovoye Pegmatite at level +252 m of the Kirovskii underground mine, Kukisvumchorr Mt., and in a pegmatite on the northern slope of Eveslogchorr Mt., both – Khibiny massif. The specimens from Khibiny were collected by A.S. Podlesnyi. At Karnasurt, tsepinite-K occurs as short-prismatic colourless or pale brown crystals up to 0.5 mm long in pseudomorphs after murmanite lamellae; associated minerals are kuzmenkoite-Mn, lemmleinite-Ba, manganneptunite, aegirine, yofortierite, natrolite, chabazite-Ca *etc.* At Kukisvumchorr, tsepinite-K was found as well-shaped brown, brown-orange or colourless prismatic crystals up to 1 mm. It is associated with elpidite (epitactic overgrowths of tsepinite-K on elpidite are typical), vuoriyarvite-K, microcline, aegirine, quartz, calcite, epididymite, eudidymite, hilairite, donnayite, celadonite, strontianite *etc.* At Eveslogchorr, pink long-prismatic to acicular crystals (up to 1 mm) of tsepinite-K occur in cavities of feldspar-natrolite-analcime zone of a pegmatite, with aegirine, astrophyllite, vuoriyarvite-K, ancylite-(Ce), fluorite *etc.* (Chukanov *e.a.*, 2003d).

Name: K-dominant analogue of tsepinite-Na.

IMA No.: 2002-005. **TS:** FMM 91044.

TSEPINITE-Na, $(Na,H_3O,K,Sr,Ba)_2(Ti,Nb)_2[Si_4O_{12}](OH,O)_2 \cdot 3H_2O$

photo 61, 62

Labuntsovite group

Tsepinite-Na was first described from two peralkaline pegmatites in the Khibiny and Lovozero massifs, Kola Peninsula, Russia. The holotype specimen was found at Khibinapakhchorr Mt., Khibiny massif. Co-type locality is the Pegmatite #45,

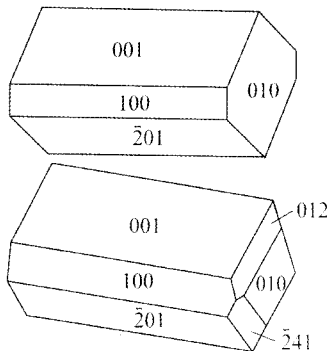

Crystals (polysynthetic twins) of **tsepinite-Na** from Khibinpakhkchorr Mt., Khibiny (Shlyukova *e.a.*, 2001).

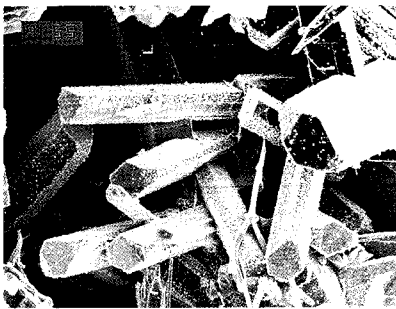

Tsepinite-Na crystals. Kirovskii mine, Kukisvumchorr Mt., Khibiny, Kola Peninsula, Russia. SEM image. Magnification: 750 \times . Specimen: A.S. Podlesnyi, photo: I.V. Pekov.

Lepkhe-Nel'm Mt., Lovozero massif. At Khibinpakhkchorr, tsepinite-Na occurs as white to colourless short-prismatic crystals up to 1 mm, typically forming epitactic overgrowths on orange long-prismatic labuntsovite-Mn crystals. They are found in cavities of a hydrothermally altered pegmatite, with aegirine, microcline, arfvedsonite, aenigmatite, analcime, natrolite, catapleite, apophyllite, fluorite, epidymite, sphalerite, *etc.* At Lepkhe-Nel'm, flattened long-prismatic white, cream-coloured or light-brown crystals (up to 1 cm long), usually split, are associated with other labuntsovite-group minerals, lamprophyllite, eudialyte, tainiolite, aegirine, fluorapatite, natrolite, neptunite, tundrite-(Ce), rancieite *etc.* Partial pseudomorphs of vinogradovite, Nb-rich titanite and tsepinite-Na after lorenzenite are typical for this pegmatite (Shlyukova *e.a.*, 2001).

Name: in honour of Anatolii Ivanovich TSEPIN (b. 1946), Russian physicist, a specialist in electron microprobe analysis who obtained the first electron probe data for labuntsovite-group minerals: Institute of Geology of Ore Deposits, Petrography, Mineralogy, and Geochemistry of Russian Academy of Sciences (IGEM), Moscow. Suffix-modifier -Na reflects prevailing of Na among extra-framework cations, in accordance with IMA-accepted nomenclature for labuntsovite-group minerals (Chukanov *e.a.*, 2002b).

IMA No.: 2000-046. *TS:* FMM 92095.

TSEPINITE-Sr, $(\text{Sr,Ba,K})(\text{Ti,Nb})_2(\text{Si}_4\text{O}_{12})(\text{OH},\text{O})_2 \cdot 3\text{H}_2\text{O}$ *Labuntsovite group*

Tsepinite-Sr was described from three peralkaline pegmatites in the Khibiny and Lovozero massifs, Kola Peninsula, Russia. The holotype specimen was found at right bank of the Astrofillitovyi Stream, Eveslogchorr Mt., Khibiny massif. Co-type localities are Khibinpakhkchorr Mt., Khibiny, and the Pegmatite #45, Lepkhe-Nel'm Mt., Lovozero massif. At Eveslogchorr, the mineral occurs in cavities of the hydrothermally altered core of a nepheline-aegirine-microcline pegmatite, with albite, natrolite, analcime, leifite, thorite, takanelite, vuoriyarvite-K, kuzmenkoite-Zn, tsepinite-Na, tsepinite-K, tsepinite-Ca *etc.* Tsepinite-Sr forms colourless to white coarse prismatic crystals up to 0.2 x 0.4 x 2 mm and crusts up to 0.3 x 4 x 5 mm on vuoriyarvite-K pseudomorphs after vuonnemite. At Khibinpakhkchorr, the mineral was found as small zones in crystals of tsepinite-Na. At Lepkhe-Nel'm, tsepinite-Sr occurs as light beige prismatic crystals up to 3 mm long overgrowing lamprophyllite and eudialyte in cavities (Pekov *e.a.*, 2005c).

Name: Sr-dominant analogue of tsepinite-Na.

IMA No.: 2004-008. *TS:* FMM 91651.

TUMCHAITE, $\text{Na}_2(\text{Zr,Sn})\text{Si}_4\text{O}_{11} \cdot 2\text{H}_2\text{O}$

Tumchaite, a Zr-analogue of penkvilksite-1M, was discovered in the core of a borehole at the Neskevara (Neskevaara) Hill, central part of the Vuoriyarvi massif, North Karelia (near the boundary of Karelia with Kola Peninsula), Russia. It was found as single lens-like nodule of 0.5 x 1.0 x 1.5 cm in hydrothermally altered dolomite-calcite carbonatite, with pyrite and chlorite. Tumchaite forms colourless to white coarse tabular crystals up to 0.2 x 1.2 x 2.5 mm (Subbotin *e.a.*, 2000).

Name: for Tumcha River near Vuoriyarvi massif.

IMA No.: 99-041. *TS:* KSC 6150; PMM 3123.

URAMARSITE, $\text{Al}(\text{UO}_2)_2(\text{AsO}_4)_2(\text{F},\text{OH}) \cdot 6.5\text{H}_2\text{O}$ *photo 12 Meta-autunite group*

Uramarsite was discovered in specimens collected by E.V. Kopchenova in 1950s in the oxidized zone of the Bota-Burum uranium deposit, Chu-Ili Mts., South

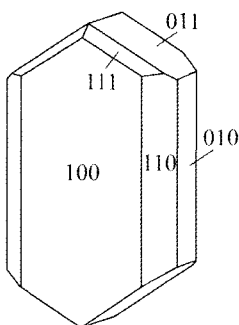

Urusovite crystal (Vergasova *e.a.*, 2000).

Kazakhstan. It occurs as light green transparent scales and quadratic lamellar crystals up to 0.1 mm, typically combined in single-crystal-like platy clusters up to 2 mm. Associated minerals are calcite, arsenopyrite, pyrite, galena, scorodite, arseniosiderite, mansfieldite, metazeunerite, trogerite, sodium uranospinite and chistyakovaite. Uramarsite fluoresces green in shortwave ultraviolet light (Sidorenko *e.a.*, 2006).

Name: reflects chemical composition: uranyl and ammonium arsenate (an arsenate analogue of phosphate mineral uramphite).

IMA No.: 2005-043. *TS:* FMM 92110; Mineralogical Museum of All-Russian Research Institute of Mineral Resources (VIMS), Moscow: 350/59zel (E.V. Kopchenova collection).

URUSOVITE, $\text{Cu}[\text{AlAsO}_5]$

Urusovite was discovered in the sublimates ($t = 410\text{--}420^\circ\text{C}$) of the Novaya (New) Fumarole on the western border of the Second cinder cone, Northern Breakthrough of the Tolbachik Main Fracture Eruption (1975–1976), Tolbachik Volcano, Kamchatka, Russia. The mineral occurs as light-green elongate platy crystals up to 0.4 mm associated with ponomarevite, piypite, sylvite, dolerophanite, euchlorine, tolbachite, tenorite and hematite (Vergasova *e.a.*, 2000).

Name: in honour of Vadim Sergeevich URUSOV (b. 1936), well-known Russian crystal chemist, Academician of Russian Academy of Sciences, Head of Department of Crystallography and Crystal Chemistry of Moscow State University and Head of Laboratory of Crystal Chemistry in Vernadsky Institute of Geochemistry and Analytical Chemistry of Russian Academy of Sciences (GEOKHI), Moscow.

IMA No.: 98-067. *TS:* FMM 89588; PU 1/19215.

VANADIUMDRAVITE, $\text{NaMg}_3\text{V}_6[\text{Si}_6\text{O}_{18}][\text{BO}_3]_3(\text{OH})_4$ *Tourmaline group*

Vanadiumdravite was discovered at the Pereval Quarry, Slyudyanka, near Baikal Lake, Irkutsk District, Siberia, Russia. It was found in metamorphosed silicate-carbonate rocks (calciphyres) with calcite, quartz, diopside, tremolite, magnesiochromite, magnesiocoulsonite, uvarovite, goldmanite, escolaitite, karelianite, cosmochlore, nataliite, dravite, titanite, *etc.* Vanadiumdravite forms hexagonal and trigonal prismatic crystals up to 0.5 x 2 mm. It is semitransparent, deep-green with yellow-brown tint, typically black visually (Reznitskii *e.a.*, 2001).

Name: V-dominant analogue of dravite.

IMA No.: 99-050. *TS:* FMM 90890, 91033.

Vergasovaite crystal (Bykova *e.a.*, 1998).

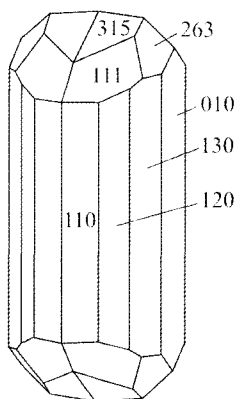

VERGASOVAITE, $\text{Cu}_3\text{O}[(\text{Mo,S})\text{O}_4][\text{SO}_4]$

Vergasovaite was first described from the Treshchina (Fissure) Fumarole, northern part of the Central fumarole field of the Second cinder cone, Northern Breakthrough of the Tolbachik Main Fracture Eruption (1975–1976), Tolbachik Volcano, Kamchatka, Russia. It was found in 1993 in active fumarole ($t = 150\text{--}170^\circ\text{C}$), on a sulfate encrustations, with chalcocyanite, dolerophanite, euchlorine, fedotovite, tenorite, anglesite and gold. Vergasovaite forms transparent olive-green prismatic crystals up to 0.3 mm typically combined in radial aggregates (Bykova *e.a.*, 1998).

Name: in honour of Lidia Pavlovna VERGASOVA (b. 1941), Russian mineralogist, for her great contribution to the mineralogy of exhalations of Kamchatka volcanoes, including discoveries of almost twenty new mineral species on Tolbachik;

Institute of Volcanology of Far East Branch of Russian Academy of Sciences,
 Petropavlovsk-Kamchatskii.
IMA No.: 98-009. *TS:* FMM 89304.

VITIMITE, $\text{Ca}_6\text{B}_{14}\text{O}_{19}[\text{SO}_4](\text{OH})_{14}\cdot 5\text{H}_2\text{O}$

Vitimite was discovered at the Solongo Fe-B deposit, Buryatia, Siberia (the holotype), and the Novofrolovskoye Cu-B deposit, Tur'insk ore field, North Urals, both – Russia. At Solongo, white parallel-fibrous aggregates of vitimite form veinlets up to 0.2 mm thick in hydrothermally altered kurchatovite rock with calcite, fedorovskite, priceite, ludwigite, magnetite, sphalerite and pyrite. At Novofrolovskoye, vitimite was found as a pseudomorph after unknown mineral in a cavity in skarned marble, with calcite, uralborite, formicaite and serpentine (Chukanov *e.a.*, 2002c).

Name: after Vitim Uppland where Solongo deposit is situated.

IMA No.: 2001-057. *TS:* FMM 91016, 91017.

VUORIYARVITE-K, $(\text{K,Na})_2(\text{Nb,Ti})_2\text{Si}_4\text{O}_{12}(\text{O,OH})_2\cdot 4\text{H}_2\text{O}$ *Labuntsovite group*

Vuoriyarvite-K was first found in the drillcore from the Neskevara (Neskevaara) Hill, central part of the Vuoriyarvi alkaline-ultrabasic massif, North Karelia (near the boundary of Karelia with Kola Peninsula), Russia. It occurs as white tabular crystals to 0.5 x 2 x 3 mm in cavities in dolomite-calcite carbonatite. Associated minerals are serpentine, apatite, strontianite, ewaldite, pyrite, pyrrhotite, chalcopyrite and sphalerite. The mineral was originally described as vuoriyarvite (Subbotin *e.a.*, 1998) and later renamed to vuoriyarvite-K according to IMA-accepted nomenclature for labuntsovite-group minerals (Chukanov *e.a.*, 2002b).

Name: for the type locality. Suffix-modifier -K reflects prevailing of K among extra-framework cations, in accordance with IMA-accepted nomenclature for labuntsovite-group minerals (Chukanov *e.a.*, 2002b).

IMA No.: 95-031. *TS:* FMM 88344; KSC 6151.

WILHELMRAMSAYITE, $\text{Cu}_3\text{FeS}_3\cdot 2\text{H}_2\text{O}$

Wilhelmramsayite was discovered at the Koashva Quarry of the Vostochnyi (Eastern) Mine, Koashva Mt., Khibiny massif, Kola Peninsula, Russia. It occurs in the core of a large peralkaline pegmatite, with villiaumite, thermonatrite, pectolite, aegirine, microcline, sodalite, lomonosovite, chkalovite, sphalerite, rasvumite, *etc.* Wilhelmramsayite forms dark lead-grey rectangular lamellar and tabular crystals up to 1 x 5 x 6 mm (Pekov *e.a.*, 2006a).

Name: in the memory of Wilhelm RAMSAY (1865–1928), an outstanding Finnish geologist, mineralogist and petrographer who completed first detailed studies of the Khibiny and Lovozero alkaline massifs; the results were published in 1890–1899.

IMA No.: 2004-033. *TS:* FMM 92103.

WILUITE, $\text{Ca}_{19}(\text{Al,Mg,Fe,Ti})_{13}(\text{B,Al,}\square)_5\text{Si}_{18}\text{O}_{68}(\text{O,OH})_{10}$ photo 63, 64

Vesuvianite group

Wiluite, a boron-dominant analogue of vesuvianite, is a "very old new mineral". Recent examination of the sample from its classic locality has demonstrated that boron prevails in an independent site in the crystal structure. This important feature became a reason to distinguish this mineral as an individual species in the vesuvianite group. Its historical name wiluite was preserved (Groat *e.a.*, 1998). Unfortunately, very long and complicated history of this interesting mineral is completely absent in the paper cited, and the type locality is given only approximately.

Vuoriyarvite-K crystal from the Flora spur of Selsurt Mt., Lovozero (after I.V. Pekov).

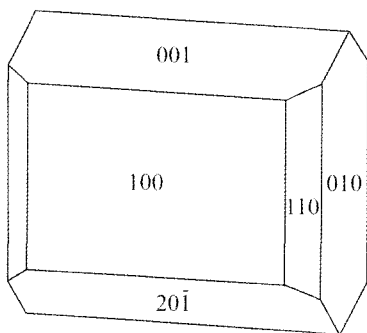

Wiluite has been known from 1790 in an area where Akhtaragda (Achtaranda) River flows to Vilyuy (another spellings: Wilui, Wiluy) River, Yakutia (Republic of Sakha-Yakutia), Siberia, Russia. On present-day maps this place, one of the classic Russian mineral localities, can be easily found: it is situated near the town of Chernyshevskiy. The discussed mineral and its locality were discovered in 1790 by famous German-Russian naturalist, Academician Erik Laxmann during his travel to Siberia. E. Laxmann carried the mineral to Saint-Petersburg (together with a mineral which is now known as grossular: the mouth of Akhtaragda River is also the type locality of this widespread mineral: Pekov, 1998). Present-day wiluite was first described as a "remarkable Wilui hyacinth" in *Neue Nordische Beitrage* by P.S. Pallas, another Russian Academician, in 1793 (i.e. before the introduction of name "vesuvianite" into the mineralogy by A.G. Werner in 1795). The name "wiluite" (original spelling: "wilouithe") was initially introduced by V.M. Severgin in 1802 for the garnet from this locality which was later renamed to grossular. The discussed vesuvianite-like mineral from Akhtaragda was named wiluite by C.C. von Leonhard in 1821. It is interesting that the first chemical analysis of a vesuvianite-group mineral known in the literature is an analysis of the sample from Akhtaragda published by Russian chemist and mineralogist T.E. Lowitz in 1796. In 1797, famous chemist M.H. Klaproth published analyses of two samples of vesuvianite: from Vesuvius and Akhtaragda. From this time, for 200 years, the mineral from Akhtaragda was considered as a variety of vesuvianite. Unlike "ordinary" vesuvianite, high boron content and positive optical sign were found for it. Many chemical analyses of wiluite from its type locality are known. In 19th century, it was independently analysed by P. Evreinov in 1847, R. Hermann in 1848, Th. Scheerer in 1855, C. Rammelsberg in 1873 and P. Jannasch in 1884. The latter has published the most complete analysis (Jannasch, 1884; Jannasch, Weingarten, 1896) including, in particular, 2.81 wt.% B_2O_3 (that is very close to the value 3.06 wt.% found by L.A. Groat *e.a.*, 1998). E.T. Wherry and W.H. Chapin (1908) reported 4.14 wt.% B_2O_3 in a sample from this locality and S.M. Kurbatov (1946) – 4.66 wt.% B_2O_3 . Detailed mineralogical data on the mineral were published by N.I. Koksharov (1853) and R.A. Prendel (1887). N.I. Koksharov described it as "*Vesuvianite from Yakutian District, from the coast of Wilui River in Eastern Siberia*". He wrote: "...this vesuvianite occurs as superb separate perfectly shaped crystals embedded in tuff-like semi-destroyed volcanic rock, near the mouth of Akhtaragda River flowing to Wilui River. It was discovered here in 1790 by Laxmann and known, generally, as wiluite. Together with wiluite, in the same rock, separate crystals of green garnet (grossular) and another, specific, destroyed mineral named Achtaragdite occur. These three minerals, abundantly included in the mass of a rock, make the latter porphyry-like. Wiluite crystals are different in size. They are

Wiluite crystals from Akhtaragda river:
a - after V.V. Lyakhovich, b - d - after
N.I. Koksharov.

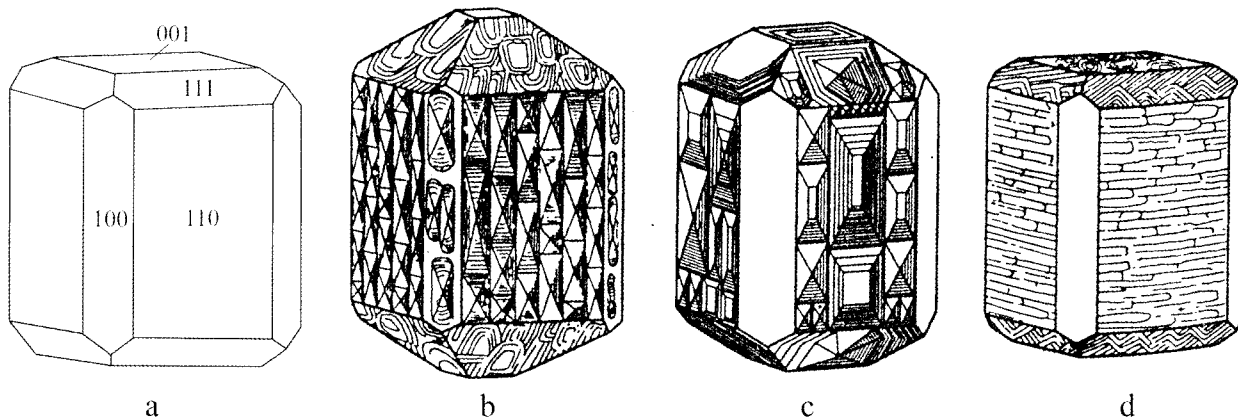

mainly up to 2 centimeters long and to 1 centimeter thick but sometimes crystals up to 5 centimeters in length, with corresponding thickness, occur. Trapezohedra and rhombic dodecahedra of grossular ingrown and overgrown on some wiluite crystals are observed..." (Koksharov, 1853). Wiluite forms dark green to dark brownish-green well-shaped tetragonal prismatic crystals. Now its crystals up to 3 x 3 x 5 cm are known. The morphology and "anatomy" of wiluite crystals and the mineralogy of a wiluite-bearing rock were studied by V.V. Lyakhovich (1954, 1955). Recently a lot of newly obtained data on wiluite and its occurrence were reported by E.V. Galuskin, I.O. Galuskina *e.a.* In particular, these researchers note that the studied crystals have a sectorial zoning with different boron content in different sectors: some sectors consist of wiluite and others are represented by B-enriched vesuvianite (Galuskin, Galuskina, 2000; Galuskin *e.a.*, 2003). Crystals of wiluite and grossular, together with "achtarandite" (in accordance with recent data, a pseudomorph after a mayenite-group mineral, probably wadalite, which is composed mainly of hydrogarnet), are abundant in a specific light-gray fine-grained rock which consists mainly of serpentine, hydrogarnet, chlorite, other hydro-silicates, carbonate and limonitized pyrite. This rock is now considered as a result of alteration of specific diopside-grossular-melilite skarnoids (Galuskina *e.a.*, 1998).

Name: for the locality on Wilui River (the historical spelling of the name of this river is derived from German; correct modern English spelling is Vilyuy but the spelling Wiluy was also used in English literature – I.P.).

IMA No.: 97-026. *TS:* Canadian Museum of Nature, Ottawa.

ZERAVSHANITE, $\text{Cs}_4\text{Na}_2\text{Zr}_3(\text{Si}_{18}\text{O}_{45})(\text{H}_2\text{O})_2$

Zeravshanite was described from the moraine of the Darai-Pioz Glacier, southern slope of the Alai Range, Tadjikistan. It was found in blocky quartz lumps, probably from the core of alkaline pegmatites. Associated minerals are aegirine, polyolithionite, reedmergnerite, pectolite, microcline, leucosphenite, stillwellite-(Ce), sogdianite, sugilite, turkestanite, pyrochlore, neptunite, arfvedsonite, kapitsaite-(Y), berezanskite, tienshanite, darapiosite, dusmatovite, tadjhikite, pekovite, baratovite, galena, bismuth, sphalerite, calcite, fluorite, fluorapatite and fluorapophyllite. Zeravshanite occurs as aqua-transparent colourless grains and their clusters up to 0.2 mm in quartz-pectolite aggregates. Graphic intergrowths of zeravshanite with quartz, aegirine, arfvedsonite or pectolite were also observed (Pautov *e.a.*, 2004b).

Name: for Zeravshan Range, one of three mountain ranges (Zeravshan, Turkestan and Alai) jointed close to Darai-Pioz Glacier.

IMA No.: 2003-034. *TS:* FMM 92048.

ZIRSILITE-(Ce), $(\text{Na}, \square)_{12}(\text{Ce}, \text{Na})_3\text{Ca}_6\text{Mn}_3\text{Zr}_3\text{Nb}(\text{Si}_{25}\text{O}_{73})(\text{OH})_3(\text{CO}_3)\cdot\text{H}_2\text{O}$

Eudialyte group

Zirsilite-(Ce) was discovered in a specimen from the moraine of the Darai-Pioz Glacier, southern slope of the Alai Range, Tadjikistan. It was found by V.D. Dusmatov in a lump of an alkaline pegmatite which mainly consists of microcline and quartz, with subordinate stillwellite-(Ce), turkestanite ("ekanite"), polyolithionite, titanite, pyrochlore, fluorite *etc.* Eudialyte-group minerals are represented by isometric zoned crystals up to 2 cm. They consist of bright yellow to pinkish-yellow carbokentbrooksit core and thin (0.5–2 mm) light cream-coloured zirsilite-(Ce) rim (Khomyakov *e.a.*, 2003a).

Name: reflects the crystal chemical features: Zr-silicate with Ce maximum of REE which are dominant in the N(4) site of the structure.

IMA No.: 2002-057. *TS:* FMM 92100.