

CRYSTAL-CHEMICAL CHARACTERIZATION OF CLINOPYROXENES BASED ON EIGHT NEW STRUCTURE REFINEMENTS¹

JOAN R. CLARK, DANIEL E. APPELMAN, AND J. J. PAPIKE

U. S. Geological Survey, Washington, D.C. 20242

ABSTRACT

Comparison of new crystal-structure refinements for spodumene, $\text{LiFe}^{2+}\text{Si}_2\text{O}_6$, synthetic ureyite, acmite, diopside, augite, a $C2/c$ omphacite, and a $P2$ omphacite with published refinements for jadeite, johannsenite, $\text{NaIn}^{3+}\text{Si}_2\text{O}_6$, fassaite, and another $P2$ omphacite indicates that the structures are strikingly similar throughout the range of chemical compositions. The "end-member" clinopyroxenes are ordered within the limits of resolution. Bonding can be satisfactorily explained in terms of an essentially ionic model without invoking additional covalent effects. Except for $P2$ omphacites, the charge and size of the $M2$ cations determine the structure type: if $M2$ is Ca or Na, $C2/c$ is expected; if $M2$ is Li, $C2$; and if $M2$ is Mg or Fe^{2+} , $P2_1/c$ or orthorhombic. Precise bond distances for ordered "end-member" clinopyroxenes can be used in determining T and $M1$ site contents of intermediate-composition clinopyroxenes, and ferrous iron is disordered in such clinopyroxenes. "Ideal" $P2$ omphacite, $\text{Ca}_{0.5}\text{Na}_{0.5}\text{Mg}_{0.5}\text{Al}_{0.5}\text{Si}_2\text{O}_6$, is expected to have Mg and Al fully ordered in the $M1$ octahedral chains, but in the $M2$ sites the maximum amount of order in alternating sites is $\frac{1}{2}$ Ca, $\frac{1}{2}$ Na, and $\frac{1}{2}$ Na, $\frac{1}{2}$ Ca.

INTRODUCTION

In a recent review of the crystal chemistry of pyroxenes, Zussman (1968) pointed out that before 1959 very few details of the crystal structures were known. Since then, although the results of several modern refinements have been published, the structures of a number of "end-member" pyroxenes, including diopside, $\text{CaMgSi}_2\text{O}_6$, have not been examined by modern methods. We have therefore carried out precise structure refinements of diopside, acmite $\text{NaFe}^{3+}\text{Si}_2\text{O}_6$, ureyite $\text{NaCr}^{3+}\text{Si}_2\text{O}_6$, spodumene $\text{LiAlSi}_2\text{O}_6$, and synthetic $\text{LiFe}^{3+}\text{Si}_2\text{O}_6$ (Table 1). The results of these refinements are presented here and are compared with those previously reported for jadeite, $\text{NaAlSi}_2\text{O}_6$ (Prewitt and Burnham, 1966), johannsenite, $\text{CaMn}^{2+}\text{Si}_2\text{O}_6$ (Freed and Peacor, 1967), and synthetic $\text{NaIn}^{3+}\text{Si}_2\text{O}_6$ (Christensen and Hazell, 1967). In addition, results of refinements for three clinopyroxenes of intermediate compositions (Table 2: a $C2/c$ omphacite, a nearly Fe-free $P2$ omphacite, and a $C2/c$ augite) are also given here and are compared with those for another $P2$ omphacite (Clark and Papike, 1968) and for an Al-rich pyroxene that approximates fassaite (Peacor, 1967). In the discussion to follow, the crystallographic nomenclature for clinopyroxenes is essentially that proposed by Burnham *et al.* (1967). The "end-member" clinopyroxene crystals that we have studied are fully ordered within the limits of the X-ray diffraction method (except for the $\text{LiFe}^{3+}\text{Si}_2\text{O}_6$, as explained later), and in the following discussion they are all referred to as ordered clinopyroxenes.

EXPERIMENTAL DATA

Crystallographic, chemical and X-ray diffraction powder data. Crystallographic data and information about the source of the crystals used for the structural studies are given in Table 1 for eight ordered clinopyroxenes and in Table 2 for five clinopyroxenes of intermediate compositions. The relationship of the cell parameters to chemical composition and structure is dis-

cussed at the end of the paper. In most cases, the cell parameters were obtained by least-squares refinement of powder X-ray data derived from diffractometer measurements taken with Ni-filtered Cu radiation (Cu $K\alpha_1$, $\lambda = 1.5405$ Å). The refinement program for the IBM 360/65 is described by Appleman and Evans (1967). Bulk chemical and electron-microprobe analyses (Tables 2, 3) indicate that the ordered clinopyroxenes and the Venezuelan $P2$ omphacite have compositions close to ideal. A trace amount of Ca was detected in the synthetic ureyite crystals and is attributed to impurity of a reagent used in the synthesis (L. Fuchs, oral commun., 1968). The synthetic $\text{LiFe}^{2+}\text{Si}_2\text{O}_6$ crystals contain about 0.10 atom of Fe^{3+} per formula unit, a point discussed later, and this occurrence is due to partial reduction of iron during the quench process (D. B. Stewart, oral commun., 1968).

Determination of the space groups was confirmed during the present study by examination of single-crystal precession photographs and by checking individual reflections manually on the single-crystal diffractometer. The spodumenes have from two to ten weak reflections of the type $h0l$ with $l = 2n + 1$, violating the c -glide symmetry. The $P2$ omphacites each have from 200 to 300 weak reflections of the types hkl with $h + k = 2n + 1$ and $h0l$ with $l = 2n + 1$. Reflections violating $C2/c$ symmetry requirements were sought but not observed for any of the other clinopyroxenes. A number of the crystals, including spodumene, were checked for piezoelectricity but no response was observed. A powdered sample of a known $P2$ omphacite was studied by the harmonic oscillator method (Kurtz and Perry, 1968) and showed no indication of any second harmonic generation (S. K. Kurtz and K. Nassau, written commun., 1968). This result is not surprising in view of the nearly centrosymmetric nature of the $P2$ structure.

Observed X-ray diffraction powder data for most of these clinopyroxenes are available in the XRDF, and calculated patterns are soon to be published (Borg and Smith, in press). However, powder data for synthetic $\text{LiFe}^{2+}\text{Si}_2\text{O}_6$ have never been given before, so these data are listed in Table 4, together with data for the Newry (Maine) spodumene. Similar data are also given for the Kakanui (New Zealand) augite in Table 5.

Single-crystal X-ray diffraction data. The information on data collection (crystal size, number of independent reflections, final R values, etc.) is summarized for the eight ordered clinopyroxenes in Table 6 and for the five intermediate composition pyroxenes, in Table 7. For this study the scan range was computed according to the equation for Mo $K\alpha$ X radiation suggested by Alexander and Smith (1964), with constants ad-

¹Studies of silicate minerals (13). Publication authorized by the Director, U. S. Geological Survey.

TABLE 1. CRYSTAL DATA FOR EIGHT ORDERED CLINOPYROXENES*

	Spodumene		Jadeite	Ureyite ^b	Acmite ^c		Diopside	Johannsenite
	LiAlSi ₃ O ₆	LiFe ²⁺ Si ₃ O ₆	NaAlSi ₃ O ₆	NaCr ³⁺ Si ₃ O ₆	NaFe ²⁺ Si ₃ O ₆	NaIn ³⁺ Si ₃ O ₆	CaMgSi ₂ O ₆	CaMn ²⁺ Si ₂ O ₆
	Present study	Present study	Prewitt and Burnham (1966)	Fronzel and Klein (1965); present study	Nolan and Edgar (1963); present study	Christensen and Hazell (1967)	Present study	Freed and Peacor (1967)
<i>a</i> (Å)	9.449 (3)	9.666 (2)	9.418 (1)	9.550 (16)	9.658 (2)	9.916	9.746 (4)	9.978 (9)
<i>b</i> (Å)	8.386 (1)	8.669 (1)	8.562 (2)	8.712 (7)	8.795 (2)	9.132	8.899 (5)	9.156 (9)
<i>c</i> (Å)	5.215 (2)	5.294 (2)	5.219 (1)	5.273 (8)	5.294 (1)	5.371	5.251 (6)	5.293 (5)
β (°)	110.10 (2)	110.15 (2)	107.58 (1)	107.44 (16)	107.42 (2)	107.0	105.63 (6)	105.48 (3)
Cell volume (Å ³)	388.1 (1)	416.4 (1)	401.20 (15)	418.6 (1.4)	429.1 (1)	*465.1 ^a	438.6 (3)	*466.0 ^a
Space group	C2	C2	C2/c	C2/c	C2/c	C2/c	C2/c	C2/c
Z	4	4	4	4	4	4	4	4
Calc. density, g cm ⁻³	3.184	3.427	*3.345 ^a	3.603	3.577	4.13	3.278	*3.522 ^a
Source of material	natural	synthetic	natural	synthetic	natural	synthetic	natural	natural
Locality or method of synthesis	Newry, Maine	d	Santa Rita peak area, New Idria Peak District, California	e	Green River Formation, Wyoming	f	Gouverneur talc district, Gouverneur, New York	Schio-Vincenti mine, Venetia, Italy

* Values in parentheses are one standard deviation, i.e., for 9.449 (3) read 9.449 ± 0.003 Å. An asterisk marks values not given in reference and calculated by present authors.

^b Cell parameters obtained by refinement during present study of selected data from Fronzel and Klein (1965).

^c Cell parameters and volume from Nolan and Edgar (1963); other data from present study.

^d Hydrothermal, 700° C, 2 kbar for 16 hrs, using Fe₂O₃ and Li₂SiO₃ in the LiFe²⁺Si₃O₆ ratio.

^e From melt of NaCr³⁺Si₃O₆ plus 10 wt % Na₂SiO₃ in air at 1000° C for 2 days.

^f Obtained as impurity from a hydrothermal preparation of rhombohedral indium oxide.

TABLE 2. CRYSTALLOGRAPHIC AND CHEMICAL DATA* FOR FIVE CLINOPYROXENES OF INTERMEDIATE COMPOSITIONS

	Omphacites			Augite	Fassaite ^c	
	Present study	Clark and Papike (1968)	Warner (1964); present study ^b	Present study	Peacor (1967)	
<i>a</i> (Å)	9.551 (8)	9.596 (5)	9.646 (6)	9.699 (1)	9.794 (5)	
<i>b</i> (Å)	8.751 (5)	8.771 (4)	8.824 (5)	8.844 (1)	8.906 (5)	
<i>c</i> (Å)	5.254 (4)	5.265 (6)	5.270 (6)	5.272 (1)	5.319 (3)	
β (°)	106.87 (8)	106.93 (8)	106.59 (8)	106.97 (2)	105.90 (3)	
Cell volume (Å ³)	420.2 (4)	423.9 (4)	429.9 (5)	432.5 (1)	446.2	
Space group	P2	P2	C2/c	C2/c	C2/c	
Cations per 6 oxygen atoms						
Tetrahedral	Si	1.98	1.96	1.995	1.83	1.506
	Al	0.02	0.04	0.005	0.17	0.494
	Σ	2.00	2.00	2.000	2.00	2.000
<i>M</i> cations	Ca	0.47	0.51	0.583	0.61	0.975
	Na	0.48	0.48	0.325	0.09	0.007
	Mg	0.42	0.44	0.582	0.90	0.570
	Fe ²⁺	0.05	0.10	0.116	0.11	0.063
	Fe ³⁺	0.02	0.10	0.123	0.10	0.159
	Al	0.51	0.39	0.233	0.16	0.171
	Ti	0.01	0.01	0.002	0.02	0.065
	Σ	1.96	2.03	1.964	1.99	2.010
Z	4	4	4	4	4	
Calc. density, g cm ⁻³	3.32	3.37	3.36	3.31	3.35	
Locality of mineral	Puerto Cabello, Venezuela	Tiburón Peninsula, California	Hareidland, Sunnmøre, Norway	Kakanui, New Zealand	Hessereau Hill, Oka, Quebec, Canada	
Reference for chemical analysis, mineralogy	Morgan (1967), sample Ca-1059	Coleman <i>et al.</i> (1965), sample 100-RGC-58	Schmitt (1963), sample 1725	Mason (1966)	Peacor (1967)	

* Values in parentheses are one standard deviation; for 9.551(8) read 9.551 ± 0.008 Å.

^b Cell constants obtained by refinement during present study of selected data from Warner (1964). The value for Si of 1.973 (Warner 1964) is incorrect; recalculation yields 1.995.

^c *M* cations include 0.007 atom Mn. Cell volume calculated by present authors.

TABLE 5. X-RAY DIFFRACTION POWDER DATA FOR AUGITE FROM KAKANUI, NEW ZEALAND^a

Calculated ^b		Observed ^c		Calculated ^b		Observed ^c	
<i>hkl</i>	<i>d_{hkl}</i> (Å)	<i>d_{hkl}</i> (Å)	Peak height	<i>hkl</i>	<i>d_{hkl}</i> (Å)	<i>d_{hkl}</i> (Å)	Peak height
110	6.401			330	2.134	2.135	20
200	4.638			331	2.124	2.125	40
020	4.422			421	2.101	2.101	10
111	4.415			420	2.054		
111	3.622			402	2.026	2.025	35
021	3.324	3.325	10	041	2.025		
220	3.201	3.204	55	240	1.996		
321	2.988	2.989	100	202	1.985	1.985	5
310	2.919	2.917	100	132	1.964	1.965	15
311	2.895	2.897	25	241	1.941		
130	2.810			511	1.889		
131	2.552	2.550	35	422	1.842		
202	2.548			331	1.837		
112	2.525					1.816	15
002	2.520	2.520	25			1.811	20
221	2.485	2.485	35			1.738	20
131	2.367					1.666	10
400	2.319					1.628	10
311	2.270	2.269	25			1.616	30
312	2.236					1.600	5
040	2.211					1.535	10
322	2.208					1.531	10
112	2.199	2.194	10			1.501	20
022	2.190					1.474	5
						1.404	40

^a See Table 2 for crystallographic and chemical data.^b Calculated values complete to $2\theta \leq 50.0^\circ$ ($\text{CuK}\alpha$, $\lambda = 1.5405 \text{ \AA}$).^c Measurements from diffractometer patterns with NaF as internal standard, $\text{CuK}\alpha$. Peak heights normalized to 100 using 310, 321.

and angles with associated standard deviations (s.d.) were obtained from the full matrices of the errors in atomic and cell parameters, using program BADTEA written by Finger.

Both unit weights and statistical weights were tried in the course of the refinements. Statistical weights were computed from the formula $w^{1/2} = 1/\sigma(F)$, where $\sigma(F)$ is one s.d. in $|F_o|$ determined from the counting statistics. For unit weights a weight of 1.0 was assigned to all reflections. The statistical weighting scheme was not suitable for the $P2_1$ omphacites because of the large difference in average intensity between the group of reflections with $h + k = 2n$ and the much weaker group with $h + k = 2n + 1$. For ordered $C2/c$ pyroxenes such as diopside, the two weighting schemes yielded virtually identical results. For consistency, unit weights were used for all final refinements. In Tables 6 and 7 we list both the conventional $R =$

$$\sum |F_o| - |F_c| / \sum |F_o|$$

and the so-called weighted $R =$

$$[\sum w(|F_o| - |F_c|)^2 / \sum wF_c^2]^{1/2}$$

We emphasize that $w = 1$ in all cases.

Refinement results. Atomic parameters and their standard deviations are compared with published values in Table 8 for ordered clinopyroxenes, in Table 9 for $C2/c$ intermediate composition clinopyroxenes, and in Table 10 for $P2_1$ omphacites. The anisotropic temperature factor tensors for ordered clinopyroxenes are given in Table 11. Observed and calculated structure factors obtained from the atomic parameters of Tables 8–10 are listed in Table 12.¹

¹ Table 12 may be ordered as NAPS Document #00454 from ASIS National Auxiliary Publications Service, c/o CCM Information Sciences, Inc., 22 West 34th St., New York, N.Y. 10001; remitting in advance \$1.00 for microfiche or \$3.00 for photocopies, payable to ASIS-NAPS.

TABLE 6. DATA-COLLECTION INFORMATION FOR EIGHT ORDERED CLINOPYROXENES

	Spodumene		Jadeite	Ureyite	Acmite		Diopside	Johannsenite
	$\text{LiAlSi}_2\text{O}_6$	$\text{LiFe}^{2+}\text{Si}_2\text{O}_6$	$\text{NaAlSi}_2\text{O}_6$	$\text{NaCr}^{3+}\text{Si}_2\text{O}_6$	$\text{NaFe}^{2+}\text{Si}_2\text{O}_6$	$\text{NaIn}^{3+}\text{Si}_2\text{O}_6$	$\text{CaMgSi}_2\text{O}_6$	$\text{CaMn}^{2+}\text{Si}_2\text{O}_6$
	Present study	Present study	Prewitt and Burnham (1966)	Present study	Present study	Christensen and Hazell (1967)	Present study	Freed and Peacor (1967)
Size of crystal (mm)	$0.07 \times 0.16 \times 0.23$	$0.10 \times 0.10 \times 0.16$	$0.04 \times 0.08 \times 0.22$	$0.03 \times 0.07 \times 0.13$	$0.07 \times 0.10 \times 0.20$	$0.06 \times 0.06 \times 0.3$	$0.07 \times 0.13 \times 0.20$	$0.074 \times 0.033 \times 0.173$
Radiation/filter	Mo/Nb ^a	Mo/Nb ^a	Cu/Ni ^b	Mo/Nb ^a	Mo/Nb ^b	Mo/not given ^c	Mo/Nb ^a	Not given ^d
Collection method								
Crystal axis (ϕ) for data collection	$[hh0]^*$	$[hh0]^*$	not given	$[hh0]^*$	$[hh0]^*$	not given	$[hh0]^*$	$[001]$
Absorption correction	no	yes	yes	yes	yes	no	no	yes
μ , cm^{-1}	11.	42.	108.	34.	42.	56.	20.	not given
No. of $ F_o > 0$	850	866	348	711	834	534	918	398
Isotropic R	0.037	0.050	0.045	0.056	0.054	0.055	0.043	0.066
wtd R^*	0.044	0.058	—	0.062	0.057	—	0.047	—
Anisotropic R	0.031	0.035	0.037	0.040	0.035	0.049	0.023	—
wtd R^*	0.039	0.046	—	0.047	0.039	—	0.030	—
Standard deviation in $ F $ (anisotr.)	4.34	7.04	—	3.01	3.76	—	3.80	—

^a Normal-beam, equatorial geometry, 4-circle automatic diffractometer, scintillation counter, 2θ scans.^b Equinclinination Weissenberg, scintillation detector, balanced filters.^c Inclination geometry, linear diffractometer, scintillation counter, balanced filters.^d Equi-inclination diffractometer, proportional detector.^e See text for definition of R and wtd R (so-called weighted R); $w = 1$ in all refinements.

TABLE 7. DATA-COLLECTION INFORMATION FOR FIVE CLINOPYROXENES OF INTERMEDIATE COMPOSITIONS

	Omphacites			Augite	Fassaite
	Venezuela Present study	California Clark and Papike (1968)	Norway Present study	New Zealand Present study	Quebec Peacor (1967)
Size of crystal (mm)	0.20×0.20×0.07	0.20×0.07×0.04	0.16×0.13×0.03	0.30×0.23×0.13	0.04×0.04×0.26
Radiation/filter	Mo/Nb	Mo/none	Mo/Nb	Mo/Nb	Cu/not given
Collection method	Normal beam, equatorial diffractometer, scintillation counter, 2θ scans				
Diffractometer	4-circle automatic	manual	4-circle automatic	4-circle automatic	manual
Crystal axis (φ) for data collection	[001]*	[010]*	[010]*	[010]*	c
Absorption correction	no	yes	yes	yes	yes
μ, cm ⁻¹	18.	22.	24.	23.	239.
No. of F _o > 0	1150	830	724	944	about 390
Isotropic	<i>R</i> 0.047 wtd <i>R</i> ^b 0.045	0.080 —	0.056 0.060	0.089 0.085	0.073 —
Anisotropic	<i>R</i> not done wtd <i>R</i> ^b	not done	0.046 0.052	0.049 0.054	0.064 —
Standard deviation in F (final)	4.96	—	4.44	11.03	—

* Equininclination diffractometer, proportional counter, direct counting methods with background measurements.

^b See text for definition of *R* and wtd *R* (so-called weighted *R*); ω=1 in all refinements.

CRYSTAL CHEMISTRY

The clinopyroxene crystal structure. The basic structure of the clinopyroxenes was first determined by Warren and Bragg (1928) for diopside. The distinctive features of the structure are well described and illustrated in papers by Prewitt and Peacor (1964) and Zussman (1968), as well as in the published refinements of jadeite and johannsenite, already cited. The oxygen atom O3 links between two Si atoms (Fig. 1) and is referred to as "bridging." The other two crystallographically distinct oxygen atoms O1 and O2 are each linked to only one Si (Fig. 1) and are referred to

as "nonbridging." The M1 site (Fig. 2) is octahedrally coordinated and is occupied by the cations Mg, Al^{VI}, Cr, Mn, Fe²⁺ and Fe³⁺; the M2 site (Fig. 3) is larger than M1 and is usually occupied by Ca, Na and Li. In the following discussion, we assume the reader's familiarity with the structure and concern ourselves with specific details of the crystal chemistry.

The ordered clinopyroxenes. Some features of the ordered C2/c clinopyroxenes have been described elsewhere (Appleman and Stewart, 1966; Clark, Appleman

TABLE 8. ATOMIC PARAMETERS COMPARED FOR EIGHT ORDERED CLINOPYROXENES^a

Atom	Parameter	Spodumene LiAlSi ₃ O ₆		LiFe ³⁺ Si ₃ O ₆	Jadeite NaAlSi ₃ O ₆	Ureyite NaCr ³⁺ Si ₃ O ₆	Acmite NaFe ³⁺ Si ₃ O ₆	NaIn ³⁺ Si ₃ O ₆	Diopside CaMgSi ₂ O ₆		Johannsenite CaMn ²⁺ Si ₂ O ₆
		Warren and Biscoe (1931)	Present study	Present study	Prewitt and Burnham (1966)	Present study	Present study	Christensen and Hazell (1967)	Warren and Bragg (1928)	Present study	Freed and Peacor (1967)
Si1	x	0.29	0.29411 (6)	0.29626 (9)	0.2906 (1)	0.2921 (1)	0.29051 (8)	0.2922 (3)	0.290	0.28623 (5)	0.2871 (2)
	y	.09	0.09349 (7)	.0895 (1)	.0934 (1)	.0918 (1)	.08946 (9)	.0869 (3)	.090	.09331 (5)	.0917 (2)
	z	.25	0.2560 (1)	.2663 (2)	.2277 (2)	.2333 (2)	.2351 (1)	.2477 (5)	.236	.22928 (9)	.2363 (4)
	B	—	0.15 (1)	.29 (1)	.41	.46 (2)	.29 (1)	—	—	.228 (7)	.26 (3)
O1A1	x	.11	0.1099 (2)	.1168 (2)	.1090 (2)	.1140 (3)	.1141 (2)	.1194 (7)	.124	.1156 (1)	.1203 (6)
	y	.09	0.0823 (2)	.0851 (3)	.0763 (3)	.0791 (3)	.0784 (2)	.0866 (7)	.099	.0873 (1)	.0930 (5)
	z	.14	0.1402 (3)	.1503 (4)	.1275 (4)	.1374 (5)	.1380 (4)	.1538 (13)	.139	.1422 (2)	.1541 (11)
	B	—	0.24 (2)	.42 (3)	.36	.42 (4)	.39 (2)	—	—	.33 (2)	.39 (8)
O2A1	x	.37	0.3646 (2)	.3671 (3)	.3608 (2)	.3599 (3)	.3582 (2)	.3578 (8)	.358	.3611 (1)	.3632 (5)
	y	.25	0.2673 (2)	.2576 (3)	.2630 (3)	.2583 (3)	.2558 (2)	.2467 (8)	.251	.2500 (1)	.2411 (6)
	z	.32	0.3009 (3)	.3290 (5)	.2929 (4)	.3037 (6)	.3001 (4)	.3149 (12)	.320	.3180 (3)	.3295 (10)
	B	—	0.44 (2)	.69 (3)	.48	.55 (4)	.53 (3)	—	—	.46 (2)	.47 (9)
O3A1	x	.36	0.3565 (2)	.3558 (3)	.3533 (2)	.3531 (3)	.3518 (2)	.3472 (7)	.345	.3565 (1)	.3482 (2)
	y	.01	-0.0129 (2)	.0000 (3)	.0070 (3)	.0103 (3)	.0079 (2)	.0112 (8)	.022	.0176 (1)	.0206 (6)
	z	.000	0.0378 (3)	.0539 (5)	.0058 (4)	.0066 (6)	.0118 (4)	.0195 (11)	.000	.0647 (2)	.0043 (12)
	B	—	0.41 (2)	.72 (3)	.49	.53 (3)	.52 (3)	—	—	.39 (2)	.40 (10)
M1	y	.91	0.9066 (1)	.89867 (7)	.9060 (1)	.9076 (1)	.89866 (7)	.8945 (1)	.917	.90833 (9)	.9053 (2)
	B	—	0.17 (1)	.31 (1)	.40	.42 (1)	.37 (1)	—	—	.26 (1)	.18 (3)
	y	.31	0.2752 (9)	.2685 (6)	.3009 (2)	.3008 (3)	.2969 (2)	.3034 (8)	.305	.30154 (5)	.3019 (2)
M2	B	—	1.1 (1)	.6 (1)	.95	.77 (4)	.93 (3)	—	—	.314 (7)	.58 (3)

^a x, y, z in cycles, equivalent B (Å) from anisotropic refinement, except for johannsenite (isotropic refinement only). In C2/c oxygen, Si positions 8f, M1 and M2 positions 4c with x=0, z=0.25. Previously published values converted as necessary to obtain the same asymmetric set for all (Burnham *et al.*, 1967). Errors in parentheses are one standard deviation; for 0.2922 (3) read 0.2922 ± 0.0003.

TABLE 9. ATOMIC PARAMETERS AND SITE OCCUPANCIES FOR THREE $C2/c$ CLINOPYROXENES OF INTERMEDIATE COMPOSITIONS*

Atom	Parameters, atomic contents	Omphacite	Augite	Fassaite
		Norway	New Zealand	Quebec
		Present study		Peacor (1967)
T	x	0.2881 (1)	0.2896 (1)	0.2871 (2)
	y	0.0924 (1)	0.0924 (1)	0.0928 (2)
	z	0.2308 (2)	0.2353 (1)	0.2272 (3)
	B	0.40 (1)	0.52 (1)	0.25
	Si	2.00	1.82	1.506
	Al	0.	0.16 (+.02 Ti)	0.494
O1	x	0.1140 (3)	0.1150 (2)	0.1130 (4)
	y	0.0829 (4)	0.0865 (3)	0.0878 (4)
	z	0.1387 (6)	0.1402 (4)	0.1377 (8)
	B	0.73 (4)	0.77 (3)	0.40
O2	x	0.3604 (4)	0.3647 (3)	0.3621 (4)
	y	0.2531 (4)	0.2530 (3)	0.2546 (4)
	z	0.3136 (6)	0.3260 (5)	0.3189 (8)
	B	0.83 (4)	1.13 (3)	0.69
O3	x	0.3513 (3)	0.3526 (2)	0.3518 (4)
	y	0.0147 (4)	0.0185 (3)	0.0189 (5)
	z	-0.0002 (6)	0.0013 (4)	-0.0083 (8)
	B	0.63 (3)	1.03 (3)	0.57
M1	y	0.9048 (2)	0.9063 (1)	0.9068 (2)
	B	0.55 (3)	0.51 (2)	0.52
	Al	0.240	0.182	0.171
	Mg	0.543	0.715	0.570
	Fe	0.217 (7)	0.103 (5)	0.222
	Σ	1.000	1.000	1.028
M2	y	0.2999 (2)	0.2952 (1)	0.3043 (2)
	B	0.85 (3)	1.23 (2)	0.66
	Ca	0.590	0.616	0.975
	Na	0.320	0.090	0.007
	Mg	0.057	0.187	—
	Fe	0.033	0.107	—
	Σ	1.000	1.000	0.982

* x, y, z in cycles; equivalent isotropic B (\AA^2) taken from anisotropic refinement. In $C2/c$, T and O. positions B; M1 and M2, positions 4c with $x=0$, $z=0.25$. Errors in parentheses are one standard deviation; for 0.2881 (1) read 0.2881 \pm 0.0001. Atomic contents based on six oxygen atoms; tetrahedral site filled to 2.00 with Si and Al (also Ti for augite). For omphacite and augite, Ca, Na were fixed in M2, Al in M1 and Fe/Mg occupancy refined. Site occupancies were assumed for the fassaite with 0.065 atom Ti also in M1; its coordinates have been converted to the standard set (Burnham *et al.*, 1967) by the present authors.

and Papike, 1965). For the silicate tetrahedra in these clinopyroxenes, the final bond lengths and angles obtained from the present study are compared in Table 13 with the values published for jadeite, johannsenite and $\text{NaIn}_3\text{Si}_2\text{O}_6$.

Comparison of interatomic distances and angles for ordered clinopyroxenes of greatly differing compositions shows that certain features of the silicate chains remain constant throughout the series (Table 13). For example, the Si-O2 bond is the shortest of the four Si-O bond lengths for all eight compounds and varies only between 1.535 and 1.598 \AA , with a mean of 1.591 \AA . The O1-Si-O2 angle is the largest O-Si-O angle in each compound, subtending the longest tetrahedral edge, O1-O2. In addition, the M1-O2 distance is the shortest M1-O distance in each compound (Table 14). These constant features all involve O2. As shown in Table 15 under bond strengths in the columns headed "Ideal ionic model", O2 has an unsatisfied charge of from 0.3 to 0.4 electrons

that is by far the largest charge imbalance of the three independent oxygen atoms in these clinopyroxenes. This apparent excess negativity is compensated for by the shorter O2-Si and O2-M1 bonds and may also be responsible for the relative constancy of the Si-O2 distances throughout the series. The relationships between bond lengths and strengths are discussed in detail later in this section. The large O1-Si-O2 angles may also be due in part to the greater repulsion between the more negatively charged nonbridging oxygen atoms, a point made by McDonald and Cruickshank (1967) in connection with the refinement of Na_2SiO_3 , which has a metasilicate chain comparable to the clinopyroxene chain.

There has been considerable discussion recently about the influence of $d-p$ π bonding in causing the increase in length of Si-O bridging bonds over the value observed for nonbridging bonds (Cruickshank, 1961; McDonald and Cruickshank, 1967; Pant and Cruickshank, 1967, 1968). In sodium metasilicate, the bridging Si-O bonds average 1.672 \AA but the nonbridging Si-O bonds average only 1.592 \AA . These values are similar to those observed in the clinopyroxenes with Ca in the M2 position, which have mean values of 1.682 \AA for bridging and 1.596 \AA for nonbridging Si-O bonds. There is much less difference between the bridging and nonbridging Si-O distances in the clinopyroxenes with univalent cations in the M2 position (Table 13).

In the clinopyroxene series the increase in bridging Si-O bond distance can be directly related to the strength of the M2-O bonds. Each O3 bridging oxygen coordinates two M2 cations (except when M2 is Li), and assuming the electrostatic attraction between O3 and Ca^{2+} to be greater than that between O3 and Na^+ , and Si-O3 bridging bonds would be expected to lengthen in the Ca clinopyroxenes. In the Na_2SiO_3 structure, Na is coordinated by only five oxygens instead of eight as in the clinopyroxenes, but each bridging oxygen still has two Na neighbors. Bond-strength calculations based on a simple ionic model show that the O-Na bonds in Na_2SiO_3 have strengths of about 0.2 valence unit, very close to the strengths of the O-Ca bonds in Ca clinopyroxenes (Table 15), so the bridging oxygens in each case receive about 0.4 electron from this source. The nearly identical lengthening of the bridging Si-O bonds in Na_2SiO_3 and Ca clinopyroxenes is thus explained on the basis of local charge balance, providing further evidence for the validity of an essentially ionic model for the bonding in chain silicates.

The value of the Si-O3-SiA2 angle differs but little throughout the series of compounds (Table 13); the average for the six phases with univalent M2 is 140.1° , and for the two with Ca^{2+} , 136.3° . Again the effect of Ca^{2+} is apparent. Comparison of a related feature, the linearity of the chain "backbone", O3A2-O3A1-O3A2 ($\div 1$ in c), demonstrates that the straightest chains are found in jadeite, acmite and synthetic $\text{LiFe}^{3+}\text{Si}_2\text{O}_6$ (Table 13); in

TABLE 10. ATOMIC PARAMETERS AND SITE OCCUPANCIES COMPARED FOR TWO P2 OMPHACITES

Venezuela Present study						California Clark and Papike (1968)				
Atom ^a	Site occupancy ^b	x	y	z	B (Å ²)	Site occupancy ^c	x	y	z	B (Å ²)
M1	Fe 0.10 (1) Mg 0.82 Al 0.08	0	0.914 (1)	0	0.5 (1)	Fe 0.19 Mg 0.81	0	0.9122 (5)	0	0.2 (1)
M1(1)	Al 1.00	0	0.099 (1)	0.5	0.37 (9)	Al 0.95 Fe 0.05	0	0.1002 (5)	0.5	.3 (1)
M1 H	Fe 0.08 Al 0.92	0.5	.404 (1)	0	0.4 (1)	Fe 0.18 Al 0.82	0.5	0.4045 (5)	0	.3 (1)
M1(1)H	Fe 0.10 Mg 0.90	0.5	.595 (1)	0.5	0.25 (9)	Fe 0.20 Mg 0.80	0.5	0.5957 (5)	0.5	.2 (1)
M2	Na 0.76 (9) Ca 0.24	0	.303 (1)	0	1.1 (3)	Na 0.64 Ca 0.36	0	0.3036 (5)	0	.8 (1)
M2(1)	Na 0.25 (8) Ca 0.75	0	.7018 (3)	0.5	0.8 (2)	Na 0.36 Ca 0.64	0	0.7017 (5)	0.5	.7 (1)
M2 H	Na 0.31 (8) Ca 0.69	0.5	.8009	0	0.7 (2)	Na 0.03 Ca 0.97	0.5	0.8009	0	.8 (1)
M2(1)H	Na 0.68 Ca 0.32	0.5	.199 (1)	0.5	0.6 (2)	Na 0.64 Ca 0.36	0.5	0.1996 (5)	0.5	.8 (1)
Si 1A	1.0 for all Si, O	0.2892 (5)	.0987 (8)	0.9775 (9)	0.28 (6)	1.0 for all Si, O	.2890 (5)	0.0972 (5)	0.9774 (5)	0.17 (5)
Si 2A		.2872 (5)	.9131 (8)	.4784 (10)	0.43 (7)		.2881 (5)	0.9135 (5)	0.4820 (5)	
Si 1C		.2123 (4)	.5882 (8)	.0175 (9)	0.13 (6)		.2137 (5)	0.5880 (5)	.0196 (5)	
Si 2C		.2104 (5)	.4033 (8)	.5245 (9)	0.27 (6)		.2103 (5)	0.4027 (5)	.5232 (5)	
O1 A1		.110 (1)	.092 (1)	.864 (2)	0.3 (1)		.112 (1)	0.088 (1)	.864 (2)	0.4 (1), for all O
O1 A2		.108 (1)	.931 (1)	.399 (2)	0.2 (1)		.110 (1)	0.922 (1)	.405 (2)	
O1 C1		.386 (1)	.574 (2)	.104 (2)	0.6 (2)		.386 (1)	0.567 (1)	.103 (2)	
O1 C2		.384 (1)	.415 (1)	.622 (2)	0.5 (2)		.385 (1)	0.411 (1)	.620 (2)	
O2 A1		.363 (1)	.264 (1)	.056 (2)	0.4 (2)		.364 (1)	0.263 (1)	.066 (2)	
O2 A2		.350 (1)	.751 (1)	.556 (2)	0.7 (2)		.347 (1)	0.747 (1)	.551 (2)	
O2 C1		.139 (1)	.755 (1)	.945 (2)	0.3 (1)		.133 (1)	0.749 (1)	.939 (2)	
O2 C2		.133 (1)	.245 (2)	.438 (3)	0.6 (2)		.135 (1)	0.244 (1)	.446 (2)	
O3 A1		.356 (1)	.021 (2)	.751 (3)	0.5 (2)		.360 (1)	0.022 (1)	.757 (2)	
O3 A2		.351 (1)	.996 (1)	.253 (2)	0.3 (1)		.350 (1)	0.994 (1)	.252 (2)	
O3 C1		.155 (1)	.515 (1)	.259 (2)	0.6 (2)		.154 (1)	0.515 (1)	.255 (2)	
O3 C2		.143 (1)	.489 (2)	.742 (3)	0.3 (2)		.147 (1)	0.489 (1)	.750 (2)	

^a M atoms in positions 1a, 1b, 1c, 1d of P2; M2 H y fixed to assign origin. Other atoms in positions 2e of P2. Errors in parentheses are one standard deviation; for 0.2892 (5) read 0.2892 ± 0.0005.

^b Total occupancy fixed at 1.0; chemical contents fixed from adjusted analysis for Venezuelan omphacite (see text). The errors in parentheses (one standard deviation) indicate those parameters refined.

^c Total occupancy fixed at 1.0, but chemical contents allowed to vary during refinement.

the latter the angle is 180° within the error of measurement. The chains in the two Ca clinopyroxenes, however, have the largest departures from linearity, with an average angle of 165°.

The M1 octahedral chains (Fig. 2) are a dominant structural feature in the clinopyroxenes. The average M1-O distances obtained in this study for the various M1 cations (Table 14) agree in general with values previously reported (cf. MacGillavry and Rieck, 1962). The angles of the Mg octahedron in diopside closely approximate those of a regular octahedron. The other M1 octahedra are also fairly regular, the average angular distortion being about 5° and the largest distortion, about 13°. Zussman

(1968) suggested that the Mn²⁺ cation represents the upper size limit for M1 occupancy; the In³⁺ cation appears to be very nearly the same size as Mn²⁺, so that the clinopyroxenes which have been studied confirm this size limitation. The In-In closest approach is, however, appreciably longer (by about 0.1 Å) than any other M1-M1 contact observed. The Si-O-M1 angles, as well as the Si-O-M2 angles (Table 16), vary little across the series and show no apparent dependence on the kind of M1 or M2 cation. Comparison of acmite with synthetic Na-Fe³⁺Ge₂O₆, which has the clinopyroxene structure (Solov'eva and Bakakin, 1967), would be interesting to show the effects on the structure of substituting Ge for Si.

TABLE II. ANISOTROPIC TEMPERATURE FACTOR TENSOR VALUES COMPARED FOR ORDERED CLINOPYROXENES*

Atom	ij of β_{ij}	Spodumene LiAlSi ₃ O ₆ Present study	LiFe ³⁺ - Si ₂ O ₆ Present study	Jadeite NaAl- Si ₂ O ₆ Prewitt and Burnham (1966)	Ureyite NaCr ³⁺ - Si ₂ O ₆ Present study	Acmite NaFe ³⁺ - Si ₂ O ₆ Present study	Diopside CaMg- Si ₂ O ₆ Present study
Si	11	4.2 (5)	13.3 (8)	11 (1)	15 (1)	4.9 (6)	5.5 (4)
	22	6.0 (6)	10.9 (8)	17 (2)	13 (1)	7.3 (7)	7.0 (4)
	33	15 (2)	14 (2)	36 (5)	15 (3)	38 (2)	25 (1)
	12	-1.8 (5)	-1.6 (6)	0 (1)	-1 (1)	-0.8 (5)	-0.2 (3)
	13	3.0 (7)	9 (1)	6 (2)	2 (1)	-2.9 (9)	2.6 (5)
O1	23	-1.0 (8)	-1 (1)	-1 (2)	-2 (1)	0 (1)	-0.9 (6)
	11	6 (1)	15 (2)	4 (3)	16 (2)	6 (2)	6.3 (9)
	22	11 (2)	17 (2)	20 (3)	18 (3)	12 (2)	12 (1)
	33	18 (4)	31 (6)	32 (9)	19 (7)	46 (6)	35 (3)
	12	-1 (1)	-1 (2)	-4 (2)	-1 (2)	-1 (1)	0.6 (8)
O2	13	0 (2)	11 (3)	0 (4)	3 (3)	-5 (2)	1 (1)
	23	0 (2)	-3 (3)	-7 (4)	4 (4)	1 (3)	2 (2)
	11	14 (1)	28 (2)	10 (3)	22 (3)	14 (2)	15 (1)
	22	12 (2)	15 (2)	20 (3)	15 (3)	8 (2)	9 (1)
	33	64 (5)	82 (8)	47 (9)	38 (8)	75 (6)	49 (4)
O3	12	-6.5 (1)	-10 (2)	-4 (2)	-6 (2)	-5 (2)	-5.6 (8)
	13	15 (2)	28 (4)	0 (4)	4 (4)	2 (3)	3 (2)
	23	-3 (2)	-10 (3)	2 (4)	-4 (4)	0 (3)	-1 (2)
	11	10 (1)	27 (2)	13 (3)	18 (2)	11 (2)	9 (1)
	22	24 (2)	37 (3)	22 (3)	24 (3)	19 (2)	16 (1)
M1	33	23 (4)	37 (7)	41 (10)	25 (7)	51 (6)	35 (3)
	12	2 (1)	0 (2)	-3 (2)	0 (3)	2 (2)	0 (1)
	13	2 (2)	12 (3)	9 (4)	4 (3)	0 (3)	5 (2)
	23	-12 (2)	-25 (4)	0 (4)	-12 (5)	-8 (3)	-7 (2)
	11	5.3 (8)	14.2 (6)	13 (2)	17 (1)	8.1 (5)	7.5 (7)
M2	22	7.2 (9)	9.9 (6)	15 (2)	15 (1)	8.6 (5)	7.5 (8)
	33	14 (3)	20 (2)	35 (6)	23 (2)	46 (2)	25 (2)
	13	2 (1)	8.1 (8)	5 (3)	4 (1)	-2.0 (7)	1 (1)
	11	30 (7)	25 (6)	35 (2)	35 (3)	34 (2)	18.1 (4)
	22	38 (8)	22 (7)	26 (3)	17 (3)	20 (2)	11.4 (4)
	33	134 (24)	27 (18)	74 (8)	34 (7)	84 (6)	42 (1)
	13	20 (11)	14 (8)	-2 (3)	-11 (4)	-11 (3)	-3.0 (6)

* $\beta_{ij} \times 10^4$; for $M1$ and $M2$, $\beta_{12} = \beta_{21} = 0$. Errors in parentheses are 1 standard deviation; for 4.2 (5) read 0.00042 ± 0.00005 . Temperature factor form:

$$\exp \left\{ - \sum_{i,j=1}^3 h_i h_j \beta_{ij} \right\}$$

but unfortunately the errors in bond distances for the Ge compound are so large that the comparison would be meaningless at present.

The $M2$ coordination polyhedron in the ordered clinopyroxenes is typified by the one in diopside (Fig. 3). When $M2$ is occupied by Na^+ or Ca^{2+} cations, the coordination is irregularly eightfold, with six oxygen neighbors nearby at distances averaging 2.4 Å, and two further away at an average distance of 2.8 Å (Table 16). In

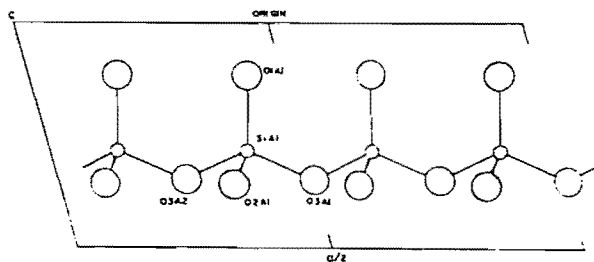

Fig. 1. The clinopyroxene tetrahedral chain as it appears in diopside. Atoms labelled according to nomenclature used in Tables 13, 21, 24.

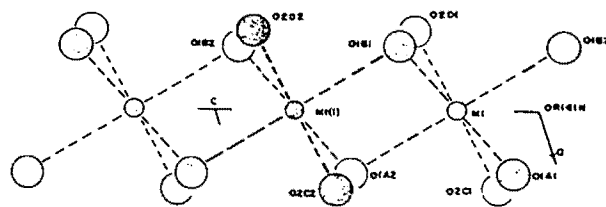

Fig. 2. The $M1$ octahedral chain as it appears in acmite. Atoms labelled according to nomenclature used in Tables 14, 20, 22.

spodumene and $\text{LiFe}^{3+}\text{Si}_2\text{O}_6$, where $M2$ is occupied by Li^+ , the two most distant oxygen atoms (O3C2 , O3D2) are removed from the coordination polyhedron, so Li^+ is irregularly coordinated by only six oxygen atoms. The average $M2$ -O distances for Na^+ and Ca^{2+} do not differ significantly, but those for Li^+ are appreciably smaller. The average Li-O distances obtained in this study are in good agreement with the few reliable values in the literature for octahedrally coordinated Li^+ . For example, the average Li-O distance in lithium dihydrogen citrate (Glusker *et al.*, 1965) is 2.18 Å, compared to 2.21 Å in spodumene.

Relationships for the bond strengths (n) associated with the various bond lengths in these clinopyroxenes can be developed following the empirical method used by Zachariasen (1963) for B-O bonds. Taking the principles established by Pauling (1929), Zachariasen assumed that the sum of bond strengths for each atom could be set equal to its valence, and that the bond lengths observed could be related empirically to the bond strengths. The method is independent of the bonding model. The Zachariasen curve for B-O bond lengths vs B-O bond strengths, which has been tested by numerous structure determinations and found successful, is compared in Figure 4 with a similarly developed curve for the Si-O bond in clinopyroxenes.

To obtain the Si-O curve, the bridging bonds in the Ca clinopyroxenes were assumed to have strengths of about 0.8 valence units, and the short Si-O2 bond was assumed to

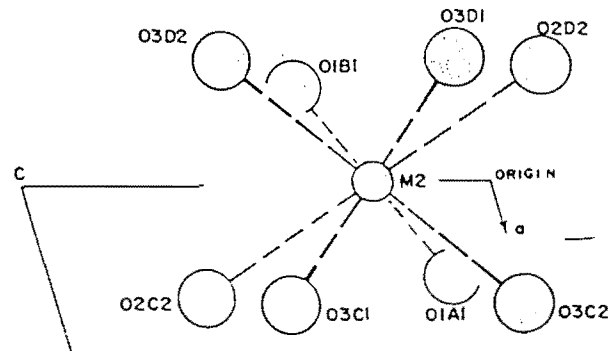

Fig. 3. The $M2$ -O coordination polyhedron as it appears in diopside. Atoms labelled according to nomenclature used in Tables 16, 20, 23.

TABLE 13. BOND LENGTHS (Å) AND ANGLES (°) FOR SILICATE TETRAHEDRA IN EIGHT ORDERED CLINOPYROXENES

Atoms*	Spodumene LiAlSi ₂ O ₆	LiFe ²⁺ Si ₂ O ₆	Jadeite NaAlSi ₂ O ₆	Ureyite NaCr ³⁺ - Si ₂ O ₆	Acnite NaFe ²⁺ - Si ₂ O ₆	NaIn ³⁺ Si ₂ O ₆	Diopside CaMgSi ₂ O ₆	Johannsenite CaMn ²⁺ Si ₂ O ₆
Source	Present study	Present study	Prewitt and Burnham (1966) ^b	Present study	Present study	Christensen and Hazell (1967) ^b	Present study	Freed and Peacor (1967) ^b
Si-O1 -O2	1.638 (2) 1.586 (2)	1.629 (2) 1.596 (3)	1.637 (2) 1.590 (2)	1.626 (4) 1.586 (3)	1.629 (2) 1.598 (2)	1.641 (7) 1.595 (8)	1.602 (2) 1.585 (1)	1.604 (6) 1.594 (6)
mean, non-brg.	1.612	1.612	1.613	1.606	1.614	1.618	1.594	1.599
Si-O3A1 -O3A2	1.622 (2) 1.626 (2)	1.626 (2) 1.627 (2)	1.628 (2) 1.636 (2)	1.640 (4) 1.645 (4)	1.637 (2) 1.646 (2)	1.633 (8) 1.664 (7)	1.664 (2) 1.687 (2)	1.683 (7) 1.693 (7)
mean, brg.	1.624	1.626	1.632	1.642	1.642	1.648	1.676	1.688
mean of 4	1.618	1.620	1.623	1.624	1.628	1.633	1.634	1.644
O1-O2	2.742 (2)	2.722 (2)	2.773 (3)	2.736 (5)	2.742 (3)	2.731	2.735 (2)	2.725 (8)
O1-O3A1	2.635 (2)	2.637 (3)	2.633 (3)	2.644 (5)	2.650 (3)	2.640	2.678 (2)	2.708 (8)
O1-O3A2	2.651 (3)	2.654 (3)	2.638 (3)	2.636 (7)	2.654 (3)	2.657	2.695 (3)	2.707 (9)
O2-O3A1	2.658 (2)	2.648 (3)	2.644 (3)	2.657 (4)	2.651 (3)	2.656	2.658 (2)	2.675 (8)
O2-O3A2	2.535 (2)	2.551 (3)	2.575 (3)	2.583 (4)	2.585 (3)	2.614	2.570 (2)	2.588 (8)
O3A1-O3A2	2.616 (1)	2.647 (1)	2.612 (4)	2.643 (5)	2.651 (1)	2.693	2.644 (3)	2.673 (3)
mean of 6	2.640	2.643	2.646	2.650	2.656	2.665	2.663	2.679
Si-SiA2	3.043 (1)	3.068 (1)	3.061 (1)	3.084 (4)	3.079 (1)	3.119	3.107 (2)	3.134 (3)
O1-Si-O2	116.5 (1)	115.1 (1)	118.5 (1)	116.8 (2)	116.4 (1)	115.17 (39)	118.25 (7)	116.84 (27)
O1-Si-O3A1	107.9 (1)	108.2 (1)	107.5 (1)	108.1 (2)	108.5 (1)	107.51 (37)	110.11 (8)	110.92 (31)
O1-Si-O3A2	108.6 (1)	109.2 (1)	107.4 (1)	107.4 (2)	108.3 (1)	107.10 (40)	109.99 (8)	110.32 (31)
O2-Si-O3A1	111.9 (1)	110.6 (1)	110.5 (1)	110.9 (2)	110.1 (1)	110.68 (44)	109.78 (7)	109.37 (29)
O2-Si-O3A2	104.2 (1)	104.6 (1)	105.9 (1)	106.1 (2)	105.6 (1)	106.70 (36)	103.46 (10)	103.80 (30)
O3A1-Si-O3A2	107.3 (1)	108.9 (1)	106.3 (1)	107.1 (2)	107.7 (1)	109.55 (40)	104.17 (9)	104.71 (24)
mean of 6	109.4	109.4	109.4	109.4	109.4	109.5	109.29	109.3
Si-O3-SiA2	139.0 (1)	141.2 (2)	139.3 (1)	139.7 (2)	139.4 (2)	142.24 (40)	135.93 (9)	136.37 (41)
O3A2-O3A1-O3A2 (+1 in c)	170.5 (2)	180 (2)	174.7 (2)	172.1 (2)	174.0 (2)	171.3	166.38 (11)	163.78 (47)

* Nomenclature adapted from Burnham *et al.*, 1967. Atoms are in the basic set unless otherwise designated (see Fig. 1). Errors in parentheses are one standard deviation; for 1.638 (2) read 1.638 ± 0.002 Å.

^b Values not given in the reference were calculated by present authors.

have a strength of about 1.25 valence units. Because the clinopyroxenes do not give many points in an intermediate range, the bond strength 1.0 was assigned at the length of 1.613 Å, an average value for the amphibole bridging distance Si-O7 taken from the refinements of glaucophane (Papike and Clark, 1968) and tremolite (Papike, Ross and Clark, 1969, this volume). Least-squares fitting of the empirical points to polynomials of degrees one to five was tried, and the best fit, both for our Si-O *vs n* points and for Zachariassen's B-O *vs n* points, was found for a third-degree polynomial. For the Si-O *vs n* data points, the following regression equation applies: Si-O (Å) = $3.6 - (4.8 \pm 1.6)n + (4.0 \pm 1.6)n^2 - (1.1 \pm 0.5)n^3$.

Similar relationships were developed for the M1 and M2 cations (Table 17) and the results for the clinopyroxenes, divided into three groups according to M2, are compared in Table 15 with the values for the ideal ionic model, obtained from use of Pauling's second rule (Pauling, 1929). The improvement is evident, but obviously further improvement of these empirical relationships would be desirable, in view of the large errors associated with the equation given above.

Spodumene and its synthetic iron analogue were refined in space group C2/c, although a few weak reflections in both crystals violate the *c*-glide criterion. Their true space-group must be C2, because a mirror plane is incompatible

TABLE 14. BOND LENGTHS (Å) AND ANGLES (°) FOR THE *M1* OCTAHEDRA IN EIGHT ORDERED CLINOPYROXENES*

Atoms ^b	Spodumene LiAlSi ₂ O ₆	LiFe ²⁺ Si ₂ O ₆ ^c	Jadeite NaAlSi ₂ O ₆	Ureyite NaCr ³⁺ Si ₂ O ₆	Acmite NaFe ²⁺ Si ₂ O ₆	NaInSi ₂ O ₆	Diopside CaMgSi ₂ O ₆	Johannse- nite CaMn ²⁺ - Si ₂ O ₆
	Present study	Present study	Prewitt and Burnham (1966) ^d	Present study	Present study	Christensen and Hazell (1967) ^d	Present study	Freed and Peacor (1967) ^d
<i>M1</i> -O1A1, B1	1.997 (2)	2.139 (2)	1.996 (2)	2.039 (3)	2.109 (2)	2.211 (7)	2.115 (1)	2.231 (6)
-O1A2, B2	1.943 (2)	2.034 (2)	1.933 (2)	2.009 (6)	2.029 (2)	2.158 (6)	2.065 (3)	2.155 (6)
-O2C1, D1	1.818 (2)	1.921 (2)	1.856 (2)	1.947 (3)	1.936 (2)	2.056 (8)	2.050 (1)	2.134 (6)
mean of 6	1.919	2.031	1.928	1.998	2.025	2.142	2.077	2.173
O1A1-O1B1	2.694 (4)	2.803 (4)	2.726 (4)	2.775 (6)	2.798 (4)	2.85	2.781 (3)	2.845
O2C1-O2D1	2.787 (4)	2.963 (5)	2.790 (4)	2.897 (7)	2.941 (4)	3.10	2.981 (3)	3.064
(2) O1A1-O2C1	2.661 (2)	2.843 (3)	2.716 (4)	2.815 (5)	2.860 (3)	3.05	3.013 (2)	3.208
(2) O1A1-O1A2	2.951 (2)	3.030 (2)	2.918 (2)	2.975 (5)	2.985 (2)	3.06	3.051 (3)	3.147
(2) O1A2-O2C1	2.705 (2)	2.931 (3)	2.677 (3)	2.797 (5)	2.819 (3)	3.04	2.878 (3)	3.009
(2) O1A2-O2D1	2.697 (2)	2.784 (3)	2.818 (4)	2.904 (6)	2.964 (3)	3.13	2.979 (3)	3.071
(2) O1A1-O1B2	2.504 (3)	2.708 (5)	2.458 (4)	2.617 (7)	2.639 (4)	2.86	2.813 (3)	3.039
mean of 12	2.710	2.863	2.724	2.824	2.856	3.02	2.936	3.041
<i>M1</i> - <i>M1</i> (1)	3.042 (1)	3.177 (1)	3.066 (1)	3.089 (4)	3.189 (1)	3.302	3.092 (2)	3.164
<i>M1</i> -SiA1	3.181 (1)	3.282 (1)	3.306	3.242 (3)	3.289 (1)	3.484	3.267 (1)	3.352
<i>M1</i> -SiA2	3.106 (2)	3.208 (1)	3.205	3.165 (8)	3.188 (1)	3.390	3.214 (3)	3.301
<i>O</i> - <i>M1</i> - <i>O</i> Angles								
O1A2, O1B2	174.5 (1)	172.1 (1)	170.1 (1)	173.4 (2)	168.7 (1)	167.74 (25)	177.8 (1)	179.2
(2) O1A1, O2D1	167.8 (1)	169.7 (1)	166.1 (1)	169.2 (1)	167.3 (1)	169.63 (26)	171.3 (1)	172.9
O1A1, O1B1	84.8 (1)	81.9 (1)	86.2 (1)	85.8 (2)	83.1 (1)	80.15 (28)	82.2 (1)	79.2
O2C1, O2D1	100.0 (1)	100.9 (2)	97.5 (2)	96.1 (2)	98.9 (1)	97.7	93.3 (1)	91.8
(2) O1A1, O2C1	88.3 (1)	88.7 (1)	89.6 (1)	89.8 (2)	89.9 (1)	91.33 (29)	92.6 (1)	94.6
(2) O1A1, O1A2	97.0 (1)	93.1 (1)	95.9 (1)	94.6 (1)	92.3 (1)	88.82 (25)	93.8 (1)	91.7
(2) O1A1, O1B2	78.9 (1)	80.9 (1)	77.4 (1)	80.6 (1)	79.2 (1)	81.78 (25)	84.6 (1)	87.7
(2) O1A2, O2C1	92.0 (1)	95.6 (1)	89.9 (1)	89.8 (2)	90.6 (1)	92.22 (26)	88.8 (1)	89.1
(2) O1A2, O2D1	91.6 (1)	89.4 (1)	96.1 (1)	94.4 (2)	96.7 (1)	95.84 (26)	92.8 (1)	91.5
Si-O1A1- <i>M1</i>	121.9 (1)	120.6 (1)	123.5	124.0 (2)	122.7 (1)	122.7	122.4 (1)	121.0
Si-O1A2- <i>M1</i>	120.1 (1)	121.9 (1)	120.0	120.6 (2)	120.9 (1)	121.5	122.0 (1)	122.1
Si-O2C1- <i>M1</i>	148.2 (1)	143.8 (2)	147.2	145.8 (2)	145.8 (1)	144.9	145.7 (1)	145.2

* Errors in parentheses are one standard deviation; for 1.997 (2) read 1.997 ± 0.002 Å.

^b When atoms for only one of the two symmetrically related distances or angles are designated, reference to Fig. 2 will aid identification of the other pair; e.g., O1A1-O1C1 = O1B1-O1D1, etc.

^c Actual *M1* occupancy close to $\text{Fe}^{1-x}\text{Fe}^{2+x}\text{Si}_2\text{O}_6$.

^d Values not given in the reference were calculated by present authors.

with the clinopyroxene structure. The refinements presented in this paper thus represent average structures, and these are almost identical, even in detail, to those of the true *C2/c* clinopyroxenes. The major difference is, of course, the change in *M2* coordination from eight to six, discussed above. Because the synthetic compound contained some Fe^{2+} , as previously mentioned, the occupancy of Fe^{2+} against Li^+ in *M2* was refined, and the true formula for the crystal studied is $(\text{Li}_{1-x}\text{Fe}_x)^{2+}(\text{Fe}_{1-x}\text{Fe}_x)^{2+}\text{Si}_2\text{O}_6$, where $x = 0.048 \pm 0.05$. This substitution affects the bond lengths because the average *M2*-O distance for the synthetic is slightly longer than the Li-O in spodumene (Table

16) and the average *M1*-O is slightly longer than the Fe^{3+} -O in acmite (Table 14).

Only pyroxenes with eight-coordinated *M2* cations have the *C2/c* (diopside type) pyroxene structure; all those with six-coordinated *M2* sites are in different space-groups: *P2₁/c* (clinoenstatite type), *Pbcu* (enstatite type), *Pbcn* (proposed protoenstatite type), or *C2* (spodumene type.) The differences in detail among these structure types have been summarized by Appleman *et al.* (1966), and specific references to structure determinations are given in Table 15.

In the spodumene *C2* structure, as in the diopside *C2/c*

TABLE 15. BOND STRENGTHS IN ORDERED CLINOPYROXENES

Bond	$M2=Li^+$			$M2=Na^+$			$M2=Ca^{++}$		
	Average distance (Å)	Bond strength		Average distance (Å)	Bond strength		Average distance (Å)	Bond strength	
		Ideal ionic model	Present study		Ideal ionic model	Present study		Ideal ionic model	Present study
O1-Si	1.634	1.000	0.93	1.635	1.000	0.93	1.603	1.000	1.12
O1-M1	1.996 to 2.138	0.500	0.42	1.996, 2.111	0.500	0.40	2.119, 2.231	0.333	0.21
O1-M1	1.942 to 2.033	0.500	0.50	1.933, 2.158	0.500	0.50	2.061, 2.155	0.333	0.40
O1-M2	2.112	0.167	0.15	2.405	0.125	0.16	2.374	0.250	0.28
Σ		2.167	2.00		2.125	1.99		1.916	2.01
O2-Si	1.591	1.000	1.26	1.593	1.000	1.25	1.591	1.000	1.26
O2-M1	1.817, 1.921	0.500	0.58	1.856 to 2.056	0.500	0.59	2.053, 2.134	0.333	0.40
O2-M2	2.223	0.167	0.15	2.402	0.125	0.16	2.332	0.250	0.34
Σ		1.667	1.99		1.625	2.00		1.583	2.00
O3-SiA1	1.625	1.000	0.90	1.634	1.000	0.93	1.675	1.000	0.82
O3-SiA2	1.625	1.000	0.90	1.648	1.000	0.89	1.690	1.000	0.80
O3-M2	2.357	0.167	0.20	2.435	0.125	0.11	2.606	0.250	0.22
O3-M2	[3.159]	—	—	2.812	0.125	0.07	2.746	0.250	0.16
Σ		2.167	2.00		2.250	2.00		2.500	2.00

structure, all the tetrahedral chains are equivalent. However, in spodumene two crystallographically distinct tetrahedra alternate along this chain, whereas in diopside all tetrahedra are of the same kind. Thus the chains in spodumene have more freedom to adapt to the coordination requirements of the small Li^+ cation. Table

8 shows that the principal differences in atomic coordinates between the spodumene and the other ordered clinopyroxenes are in the $M2$ coordination polyhedra ($M2$ and $O3$). This is additional evidence that accommodation to the small size of the Li^+ cation is chiefly responsible for the degradation in symmetry from $C2/c$ to $C2$. Note

TABLE 16. BOND LENGTHS (Å) AND SOME ANGLES (°) FOR THE $M2$ CATIONS IN EIGHT ORDERED CLINOPYROXENES*

Atoms ^b Oxygen of $M2-O$	Spodumene $LiAlSi_2O_6$ Present study ^c	$LiFe^{++}Si_2O_6$ Present study ^c	Jadeite $NaAlSi_3O_6$ Prewitt and Burnham (1966) ^d	Ureyite $NaCr^{++}Si_2O_6$ Present study	Acmite $NaFe^{++}Si_2O_6$ Present study	$NaIn^{++}Si_2O_6$ Christensen and Hazell (1967) ^d	Diopside $CaMgSi_2O_6$ Present study	Johannsenite $CaMn^{++}Si_2O_6$ Freed and Peacor (1967) ^d
O1A1, O1B1	2.105 (6)	2.120 (5)	2.357 (3)	2.378 (4)	2.398 (3)	2.487 (9)	2.360 (1)	2.384 (6)
O2C2, O2D2	2.278 (2)	2.167 (3)	2.413 (2)	2.389 (7)	2.415 (2)	2.394 (6)	2.353 (3)	2.316 (6)
O3C1, O3D1	2.251 (6)	2.459 (5)	2.363 (3)	2.424 (4)	2.430 (3)	2.517 (9)	2.561 (2)	2.651 (7)
O3C2, O3D2	[3.144 (5)]	[3.178 (4)]	2.741 (2)	2.764 (4)	2.831 (3)	2.922 (9)	2.717 (1)	2.771 (6)
mean of 6	2.211	2.249	2.378	2.397	2.414	2.466	2.425	2.450
mean of 8	—	—	2.469	2.489	2.518	2.580	2.498	2.530
Angles								
Si-O1A1-M2	114.6 (1)	118.5 (1)	109.8	112.4 (2)	112.9 (1)	115.0	115.5 (1)	119.6
Si-O2C2-M2	93.8 (2)	100.3 (2)	94.1	95.9 (2)	95.8 (1)	97.5	102.2 (1)	104.6
Si-O3C1-M2	116.4 (1)	112.4 (1)	103.6	102.4 (2)	103.8 (1)	103.6	101.1 (1)	100.4
Si-O3D1-M2	93.7 (1)	88.4 (1)	94.7	93.0 (2)	94.0 (1)	91.2	91.4 (1)	89.2
Si-O3C2-M2	—	—	114.7	116.3 (2)	115.9 (1)	117.5	117.8 (1)	118.8
Si-O3D2-M2	—	—	89.0	89.5 (2)	88.5 (1)	87.8	94.6 (1)	95.7

* Errors in parentheses are one standard deviation; for 2.105 (6) read 2.105 ± 0.006 Å.

^b See Fig. 3.

^c Actual $M2$ occupancy close to $Li_{0.2}Fe^{++}_{0.8}$.

^d Values not given in reference were calculated by present authors.

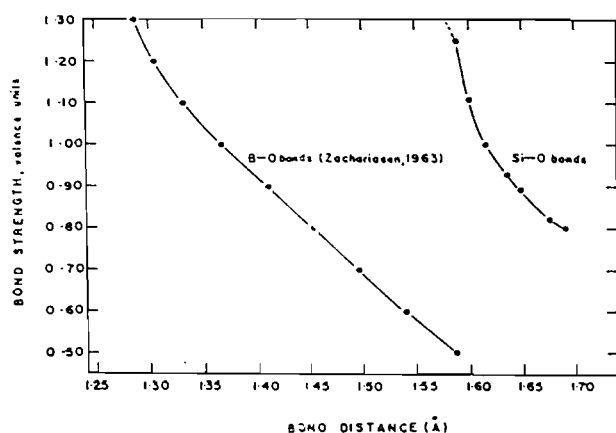

Fig. 4. Empirical curves for bond strengths vs. bond distances for boron-oxygen bonds (Zachariasen, 1963) and silicon-oxygen bonds in clinopyroxenes.

that the deviations from $C2/c$ symmetry are very small; in fact, even the temperature factors for the spodumenes refined in $C2/c$ are entirely comparable to those found in the other ordered clinopyroxenes.

One must also explain why spodumene and $\text{LiFe}^{3+}\text{Si}_2\text{O}_6$ do not crystallize with the enstatite or clinoenstatite structures. The closely related enstatite and clinoenstatite structure types contain two kinds of tetrahedral chains, A and B, segregated by layers. Comparison of the O3-O3-O3 angles shows that the Si A chains are very like those in the diopsidic pyroxenes, but the Si B chains are much more strongly kinked (Table 18). This distortion, discussed by Morimoto, Appleman and Evans (1960), is primarily due to a rotation of the tetrahedra around a line connecting Si B with O1 B (*cf.* Fig. 1). The result, in the enstatite and clinoenstatite structures, is to decrease markedly the $M2$ -O2 bond distances and increase the $M2$ -O3 distances, relative to those in spodumene, although the average $M2$ -O distances are very similar in all of the structures listed in Table 18. This effect is exactly what would be expected, on the basis of a simple ionic charge-balance model, when doubly

charged Mg^{2+} or Fe^{2+} rather than singly charged Li^+ is present in the $M2$ site.

On the basis of the evidence considered above, we conclude that the size and charge of the cations occupying the $M2$ site chiefly determine the structure type of a pyroxene. Large singly or doubly charged $M2$ cations lead to a diopside structure, small singly charged $M2$ cations to a spodumene structure, and small doubly charged $M2$ cations, with much stronger $M2$ -O bonds, to a clinoenstatite or enstatite structure. The more complex $P2$ omphacite pyroxene structure type represents an exception and is discussed later.

Thermal ellipsoids were obtained for the atoms of those ordered clinopyroxenes for which comparable anisotropic refinements were carried out (Table 19). As might be expected, the largest rms amplitudes of about 0.13 Å are observed for Li; for Si and the oxygen atoms. rms amplitudes range from about 0.04 to 0.11 Å. The atoms in these ordered structures show relatively little anisotropy in their thermal motion, so the errors in the orientation of the thermal ellipsoids are rather high. For the same reason, it is difficult to make a general interpretation of the anisotropy. However, the results are compatible with the bonding environment of the atoms. The relative lack of anisotropy in the thermal ellipsoids is consistent with the predominantly ionic character of these structures.

The equivalent individual isotropic temperature factors for Si and O (Table 8) agree so well for all the structures that they can be taken as values representative for ordered pyroxenes, *i.e.*, Si, $0.3 \pm 0.1 \text{ \AA}^2$, and oxygen, $0.4 \pm 0.1 \text{ \AA}^2$. There is a tendency for O2 to have a slightly higher value than the other two oxygens, undoubtedly because it bonds to only three cations instead of four (Table 15).

C2/c clinopyroxenes of intermediate compositions. In order to refine the structures of the two intermediate $C2/c$ clinopyroxenes, their chemical analyses (Table 2)

TABLE 17. STRENGTH AND LENGTH OF $M1$ -O AND $M2$ -O BONDS IN CLINOPYROXENES*

Bond strength	$M1$ cations ^b			$M2$ cations ^c		
	Bond lengths (Å)			Bond strength	Bond lengths (Å)	
	Al	Fe ³⁺	Mg		Na	Ca
0.20			2.125	0.05	2.930	
.30	2.080		2.087	.10	2.630	
.40	2.005	2.135	2.055	.15	2.305	2.850
.50	1.922	2.030	2.020	.20		2.625
.60	1.842	1.920		.25		2.480
				.30		2.375
				.35		2.285

* Values taken from best-fit curve through empirical points.

^b Six-coordinated.

^c Eight-coordinated.

TABLE 18. VARIATION IN O3-O3-O3 ANGLES WITH $M2$ OCCUPANCY IN PYROXENES

$M2$ occupancy	O3A2-O3A1-O3A2 angle (°)	O3B2-O3B1-O3B2 angle (°)	Reference
Li^+	175.2	—	Average of 2 structures (Table 13)
Na^+	175.0	—	Average of 4 structures (Table 13)
Ca^{2+}	165.1	—	Average of 2 structures (Table 13)
Fe^{2+}	167.	142.	Clinoferrosilite (Burnham, 1967)
Fe^{2+}	169.	145.	Orthoferrosilite (Burnham, 1967)
Fe^{2+} (approximately)	168.	144.	Hypersthene (Ghose, 1965)
0.77 Fe^{2+} , 0.05 Mg^{2+} , 0.18 Ca^{2+}	167.	142.	Pigeonite (Morimoto and Güven, 1968)
Mg^{2+}	161.	134.	Clinoenstatite (Morimoto, Appleman and Evans, 1960)

were used to constrain the total amount of each cation present. However, the values from Table 2 were slightly altered in some cases by recalculation to bring the total occupancies of both *M1* and *M2* to 1.0. The cell contents actually used are given in Table 9 in terms of occupancies resulting from the refinements. On the basis of size considerations, we assumed that all the Na⁺ and Ca²⁺ are in *M2* and all the Al³⁺ in *M1*. We then refined the occupancy of Fe and Mg between *M1* and *M2*, assuming each site to be completely filled and using the chemical constraints.

During the site refinement, no distinction was made between Fe²⁺ and Fe³⁺, and the scattering factors used for iron were those for Fe²⁺. However, assuming the cell contents given in Table 9 to be correct, total charge balance in the structure enables us to calculate the amounts of Fe³⁺ and Fe²⁺ present, on the basis of six oxygen atoms and four cations. For the omphacite this process gives 0.08 atom of Fe³⁺ and 0.17 atom of Fe²⁺; the chemical analysis (Warner, 1964) yields approximately 0.12 atom of Fe³⁺ and 0.12 atom of Fe²⁺. For the augite, the charge balance calculation gives 0.06 atom of Fe³⁺ and 0.15 of Fe²⁺, whereas the chemical analysis (Mason, 1966) yields approximately 0.10 atom of Fe³⁺ and 0.11 of Fe²⁺. In view of these discrepancies, both in the same direction, other methods of determining the ratio and distribution of ferrous and ferric iron seemed warranted. Two methods were tried: (1) the use of Mössbauer resonance spectra, and (2) the use of bond distances.

Dr. Stefan S. Hafner, Department of Geophysical Sciences, University of Chicago, kindly examined the New Zealand augite by means of Mössbauer spectra, both at room temperature and at liquid nitrogen temperature. The detailed results of his work will appear elsewhere, but the conclusions pertinent to this paper (S. S. Hafner, written comm., 1969) are as follows: first, there is very little Fe³⁺ present, and interpretation of the spectra suggests that it is in the *M1* site, with Fe³⁺/total Fe \approx 0.10 (about 0.02 atom Fe³⁺); second, there is no doubt that Fe²⁺ is present in both the *M1* and *M2* sites; third, the ratio (Fe in *M1*)/(Fe in *M1*+*M2*) \approx 0.40. By comparison, the calculation based on charge balance, discussed in the preceding paragraph, gives Fe³⁺/total Fe \approx 0.28, and the site occupancy refinement gives (Fe in *M1*)/(Fe in *M1*+*M2*) = 0.49 \pm 0.02.

Another method of checking site occupancies in intermediate pyroxenes is based on the use of the accurate and consistent values for average *M1*-O distances obtained from the refinements of ordered clinopyroxenes. From Table 14, we may take the following average distances: Al-O = 1.923 Å (jadeite and spodumene), Mg-O = 2.077 Å (diopside) and Fe²⁺-O = 2.025 Å (acmite). From clinoferrrosilite and orthoferrrosilite (C. W. Burnham, 1967, and oral comm., 1968) we take the average Fe²⁺-O = 2.137 Å. If we assume that the average *M1*-O

distance in disordered *M1*-sites (Table 20) is simply a linear combination of the average *M1*-O distances for the various ions present, in the ratios obtained from the site-occupancy refinements, we can calculate average *M1*-O to be expected for any particular model.

Let us first assume that in the augite all the Fe³⁺ is in the *M1* site, from size considerations and the Mössbauer results. Then if Fe³⁺ = 0.06 (the value obtained from the charge balance calculation), *M1*-O (ave.) = 2.048 Å (calc.) as compared with 2.054 Å observed (Table 20). The lower calculated value indicates that too much Fe³⁺ has been assigned to *M1*. In order for the bond-distance method to yield the observed average distance of 2.054 Å, the amount of Fe³⁺ in *M1* must be reduced to approximately 0.01 atom. Using this value, a ratio Fe³⁺/total Fe \approx 0.1 is found, in excellent agreement with the Mössbauer results, but substantially less than that obtained from the chemical analysis.

It has been observed (B. Mason, oral commun., 1969) that Fe³⁺/Fe²⁺ values from chemical analyses are frequently too high in this type of mineral, due to oxidation during the analysis (*cf.* also Bancroft and Burns, 1969, this volume). Considering all evidence presented above, we conclude, first that there is very little ferric iron in this augite and the ratio Fe³⁺/total Fe is probably between 0.1 and 0.3 (*i.e.*, 0.02 to 0.06 atom Fe³⁺), and second, that virtually all the ferric iron is in the *M1* site and that the ferrous iron is disordered between *M1* and *M2*, with approximately 0.09 atom in *M1* and 0.11 atom in *M2* (Table 9).

No Mössbauer spectral analysis has been done for the *C2/c* omphacite. Using the bond lengths in the same way as for the augite, we calculate an average *M1*-O distance of 2.044 Å compared to the observed 2.040 Å, assuming the Fe³⁺ value of 0.08 atom from the charge-balance calculation with all Fe³⁺ in *M1*. In order to obtain the observed distance, Fe³⁺ must be approximately 0.12 atom, in excellent agreement with the chemical analysis. As in the augite, the evidence is consistent with the assignment of all Fe³⁺ to the *M1* site and Fe²⁺ disordered between the *M1* and *M2* sites, with approximately 0.10 atom in *M1* and 0.03 atom in *M2* (Table 9). Considering the very small amounts of iron present in these minerals, it is hardly surprising that there are some discrepancies between the values for Fe³⁺/total Fe obtained by different methods.

The present study is the first, to our knowledge, in which detailed structure determinations have been made of *C2/c* clinopyroxenes of intermediate compositions, close to augite. The site occupancies found in these minerals are somewhat unexpected. The small Al³⁺ cation is apparently well ordered in *M1*, and the large Ca²⁺ and Na⁺ cations, in *M2*. However, there is a considerable degree of Mg²⁺/Fe²⁺ disorder between the two sites: in both the omphacite and the augite the Mg²⁺/Fe²⁺ ratio in *M2* is greater than 1.0, within the error of our

TABLE 19. MAGNITUDES AND ORIENTATIONS OF THERMAL ELLIPSOIDS COMPARED FOR SIX ORDERED CLINOPYROXENES*

Pyroxene, reference	Ellipsoid axis, r_i r	Si			O1			O2					
		rms amplitude, Å	Angle (°) of r_i with			rms amplitude, Å	Angle (°) of r_i with			rms amplitude, Å	Angle (°) of r_i with		
			r_i	a	b		c	r_i	a		b	c	r_i
Spodumene, LiAlSi ₃ O ₆ , present study	1	0.034 (3)	36 (8)	55 (6)	99 (14)	0.042 (6)	61 (14)	86 (12)	49 (15)	0.045 (6)	132 (6)	138 (6)	76 (5)
	2	.042 (2)	77 (14)	96 (12)	171 (14)	.057 (5)	40 (23)	64 (29)	134 (18)	.079 (8)	52 (8)	125 (8)	136 (12)
	3	.051 (2)	57 (7)	144 (6)	89 (11)	.064 (4)	115 (25)	27 (29)	73 (22)	.092 (3)	66 (9)	111 (8)	50 (12)
LiFe ²⁺ Si ₂ O ₆ present study	1	.035 (4)	111 (3)	89 (5)	1 (4)	.057 (7)	115 (13)	82 (12)	10 (11)	.062 (7)	62 (8)	28 (6)	95 (11)
	2	.062 (3)	110 (7)	159 (7)	89 (5)	.076 (5)	141 (32)	124 (40)	90 (15)	.086 (5)	55 (8)	104 (10)	159 (6)
	3	.076 (2)	30 (6)	111 (7)	89 (3)	.082 (5)	63 (36)	143 (40)	80 (11)	.122 (4)	48 (5)	114 (4)	69 (6)
Jadeite, NaAlSi ₃ O ₆ , Prewitt and Burnham (1966) ^b	1	.067 (4)	113 (16)	83 (11)	9 (8)	.035 (16)	34 (14)	75 (8)	77 (14)	.056 (9)	36 (11)	73 (12)	75 (15)
	2	.068 (4)	163 (16)	92 (20)	107 (15)	.067 (9)	57 (15)	102 (13)	160 (14)	.079 (7)	75 (17)	52 (19)	142 (18)
	3	.080 (4)	92 (9)	173 (9)	83 (9)	.090 (7)	83 (9)	160 (9)	75 (12)	.094 (7)	122 (11)	43 (18)	55 (17)
Ureyite, NaCr ²⁺ Si ₂ O ₆ , present study	1	.043 (5)	89 (4)	83 (6)	20 (4)	.047 (10)	92 (10)	101 (11)	19 (8)	.062 (9)	72 (10)	48 (22)	57 (24)
	2	.071 (3)	78 (13)	14 (12)	100 (7)	.079 (7)	133 (32)	135 (31)	87 (15)	.076 (7)	75 (13)	51 (22)	141 (23)
	3	.081 (3)	12 (13)	102 (13)	107 (5)	.088 (6)	137 (32)	47 (31)	71 (9)	.106 (6)	156 (8)	66 (8)	73 (9)
Acmite, NaFe ²⁺ Si ₂ O ₆ , present study	1	.040 (3)	36 (3)	77 (10)	73 (3)	.041 (8)	37 (5)	82 (11)	71 (5)	.045 (8)	61 (6)	30 (7)	89 (4)
	2	.054 (3)	99 (8)	13 (10)	97 (5)	.069 (5)	90 (10)	12 (10)	102 (9)	.081 (5)	132 (7)	61 (7)	109 (8)
	3	.081 (2)	125 (3)	87 (4)	18 (3)	.092 (4)	127 (5)	80 (9)	22 (6)	.107 (4)	124 (7)	81 (5)	19 (8)
Diopside, CaMgSi ₂ O ₆ , present study	1	.049 (2)	27 (17)	72 (20)	85 (9)	.051 (4)	30 (9)	98 (9)	77 (8)	.050 (4)	62 (3)	30 (4)	87 (5)
	2	.053 (2)	67 (20)	155 (17)	106 (11)	.069 (3)	65 (14)	45 (35)	132 (34)	.079 (3)	103 (7)	72 (6)	146 (8)
	3	.059 (1)	105 (8)	107 (11)	17 (11)	.073 (3)	105 (17)	46 (35)	44 (34)	.094 (3)	149 (5)	67 (4)	56 (8)

* Errors in parentheses are one standard deviation; for 77 (14) read $77 \pm 14^\circ$.

^b Orientations recalculated to conform to those of present study using β_{ij} values and rms amplitudes given by Prewitt and Burnham (1966).

determinations. These results differ from the Fe²⁺-Mg²⁺ distributions in enstatite-like structures such as hypersthene (Ghose, 1965) and pigeonite (Morimoto and Güven, 1963), in which there is a high degree of order and the Mg²⁺/Fe²⁺ ratios in *M2* are very low. It is evident that the structures of more *C2/c* clinopyroxenes of augitic or near-augitic compositions must be investigated to determine whether a pattern of Fe²⁺-Mg²⁺ distribution exists in these minerals.

The Si-O bonds and O-Si-O angles of *C2/c* omphacite (Table 21), which has no tetrahedral aluminum, agree closely with those found for diopside (Table 13). The augite, which has 0.16 atom of tetrahedral Al per six oxygen atoms, has longer T-O distances reflecting this occupancy, as does the fassaite with 0.49 atoms of tetrahedral Al per six oxygen atoms (Peacor, 1967). By using the T-O₂ distances for these three intermediate composition clinopyroxenes, a linear relationship between T-O₂ distance and the tetrahedral Al contents can be constructed for clinopyroxenes, following the general method developed by Smith (1954) and refined by Smith and Bailey (1963). We have already shown that the T-O₂ distance is a better indicator of the amount of Al in a pyroxene tetrahedron than is the average T-O distance (Clark, Appleman, and Papike, 1963). Results from further refinements of intermediate clinopyroxenes will be needed to test the general applicability of the relationship.

These refinements all indicate that very little distortion occurs in intermediate *C2/c* clinopyroxene struc-

tures because of the multiple cation contents. The silicate chains are closely comparable to those in the most nearly corresponding ordered clinopyroxene (usually diopside), and the other features are also those that would be predicted from knowledge of the cation contents. Details of the cation distribution in the disordered structures can be inferred only indirectly from our results. There is no evidence of streaking or diffuse reflections on X-ray diffraction photographs of these minerals, so whatever short-range order exists is below the threshold of the usual X-ray diffraction analysis. The anisotropic temperature factors are larger in all directions in the disordered structures than in the ordered ones for the *M1* and *M2* cations. The rms displacements of the oxygen atoms along the *M1*-O bonds are about 50 percent greater in the disordered structures, and displacements along the *M2*-O bonds are about 20 percent greater. These effects are precisely those to be expected around disordered cation sites (Burnham, 1965).

P2 omphacites. The structure of the Venezuelan omphacite is similar in all respects to that reported for the Californian omphacite (Clark and Papike, 1968), despite the appreciably lower Fe content (0.07 atom of Fe per six oxygen atoms, instead of 0.20). The excellent agreement between these independent refinements of data from different specimens lends confidence to the results, which can be assumed applicable in general for *P2* omphacites. Because of large correlations (about 0.9) between certain parameters, the initial refinement of

O3				M1				M2			
rms amplitude, Å	Angle (°) of r_i with			rms amplitude, Å	Angle (°) of r_i with			rms amplitude, Å	Angle (°) of r_i with		
	r_i	a	b		c	r_i	a		b	c	r_i
0.043 (6)	96 (12)	68 (5)	26 (5)	0.041 (4)	80 (22)	90	30 (22)	0.11 (1)	17 (27)	90	93 (27)
.061 (5)	161 (6)	76 (6)	83 (12)	.048 (3)	10 (22)	90	120 (22)	.12 (1)	90	180	90
.101 (3)	108 (4)	153 (4)	66 (3)	.051 (3)	90	0	90	.13 (1)	107 (27)	90	3
.040 (10)	106 (5)	65 (3)	25 (3)	.046 (2)	107 (3)	90	3 (3)	.05 (2)	106 (12)	90	4 (12)
.095 (5)	162 (6)	89 (6)	88 (6)	.061 (2)	90	180	90	.09 (1)	90	180	90
.129 (4)	98 (6)	155 (3)	65 (3)	.077 (2)	17 (3)	90	93 (3)	.10 (1)	16 (12)	90	94 (12)
.067 (9)	146 (53)	105 (17)	43 (61)	.066 (6)	80 (29)	90	27 (29)	.089 (5)	69 (4)	90	38 (4)
.073 (8)	117 (58)	102 (20)	133 (61)	.074 (6)	90	180	90	.097 (5)	90	180	90
.093 (6)	71 (13)	161 (14)	93 (13)	.074 (6)	8 (29)	90	115 (29)	.136 (4)	159 (4)	90	52 (4)
.047 (10)	92 (8)	70 (7)	26 (7)	.054 (3)	91 (3)	90	16 (3)	.057 (8)	75 (3)	90	33 (3)
.088 (6)	164 (22)	76 (20)	80 (13)	.075 (2)	90	180	90	.080 (6)	90	180	90
.102 (6)	106 (22)	155 (13)	67 (7)	.086 (2)	1 (3)	90	106 (3)	.140 (5)	165 (3)	90	57 (3)
.064 (6)	41 (16)	87 (19)	67 (15)	.054 (2)	38 (2)	90	69 (2)	.086 (5)	90	0	90
.074 (5)	63 (20)	140 (8)	125 (13)	.058 (2)	90	180	90	.086 (5)	118 (3)	90	134 (3)
.101 (4)	118 (6)	130 (7)	44 (7)	.088	128 (2)	90	21 (2)	.149 (3)	152 (3)	90	44 (3)
.058 (4)	113 (27)	59 (6)	33 (8)	.052 (3)	56 (10)	90	49 (10)	.066 (1)	66 (1)	90	39 (1)
.064 (3)	156 (26)	96 (15)	98 (23)	.055 (3)	90	180	90	.068 (1)	90	180	90
.085 (3)	97 (6)	148 (5)	59 (5)	.065 (2)	146 (10)	90	41 (10)	.103 (1)	156 (1)	90	50 (1)

atomic parameters had to be handled as described by Clark and Papike (1968) by alternately fixing the parameters for one set of atoms and refining those of the other set. However, once the coordinates were close to the final values, it was possible to refine all the parameters together, including positions, occupancies, and isotropic temperature factors.

The site occupancy refinement was handled differently from the previous study (Clark and Papike, 1968), be-

cause the constraints imposed by the chemical composition were used (Finger, 1969). During initial refinements of positional parameters, site occupancies were taken from the previous *P2* omphacite study. Consideration of the average *M1*-O distances and *M1* temperature factors derived from the initial refinement showed that *M1*(1) was entirely occupied by Al^{3+} within the limits of resolution. Using average *M1*-O distances from the ordered clinopyroxenes, as described above, it was also possible

TABLE 20. BOND LENGTHS (Å) COMPARED FOR THE *M1* AND *M2* CATIONS IN SOME *C2/c* PYROXENES OF INTERMEDIATE COMPOSITIONS

	<i>M1</i> octahedron			<i>M2</i> polyhedron		
	Omphacite Present study ^b	Augite Present study ^b	Fassaite Peacor (1967) ^c	Omphacite Present study ^b	Augite Present study ^b	Fassaite Peacor (1967) ^c
<i>M1</i> occupancy				<i>M2</i> occupancy		
Mg	0.543	0.715	0.570	Ca	0.590	0.616
Al	0.240	0.182	0.171	Na	0.320	0.090
Fe	0.217 (7)	0.103 (5)	0.222	Fe	0.033	—
Ti	—	—	0.065	Mg	0.057	—
				Mn	—	0.007
<i>M1</i> -O lengths				<i>M2</i> -O lengths		
O1A1, O1B1	2.095 (3)	2.120 (2)	2.132 (4)	O1A1, O1B1	2.364 (3)	2.316 (2)
O1A2, O1B2	2.032 (4)	2.035 (2)	2.057 (5)	O2C2, O2D2	2.356 (5)	2.278 (3)
O2C1, O2D1	1.994 (3)	2.007 (3)	2.017 (4)	O3C1, O3D1	2.512 (3)	2.563 (3)
				O3C2, O3D2	2.747 (3)	2.760 (3)
Mean of six	2.040	2.054	2.069	Mean of six	2.411	2.386
				Mean of eight	2.495	2.479

^a Errors in parentheses are one standard deviation; for 2.095 (3) read 2.095 ± 0.003 Å.

^b Al, Ca, Na occupancies fixed from chemical analysis (Table 2 and text); occupancy of Mg/Fe refined.

^c Assigned from chemical analysis and size considerations; no site-occupancy refinement.

^d Calculated by present authors; the 2.530 Å average value (Peacor, 1967) appears to be a misprint.

TABLE 21. BOND LENGTHS (Å) AND ANGLES (°) COMPARED FOR THE TETRAHEDRA IN SOME *C2/c* PYROXENES OF INTERMEDIATE COMPOSITIONS

Atoms ^a	Omphacite, present study ^c	Augite, present study	Fassaite, ^b Peacor (1967)
T-O1	1.612 (3)	1.621 (2)	1.640 (5)
T-O2	1.585 (3)	1.604 (3)	1.629 (4)
mean, non-brg.	1.598	1.612	1.634
T-O3	1.657 (3)	1.662 (2)	1.685 (5)
T-O3A2	1.668 (3)	1.674 (2)	1.697 (5)
mean, brg.	1.662	1.668	1.691
mean of 4	1.630	1.640	1.663
O1-O2	2.739 (4)	2.758 (3)	2.792 (6)
O1-O3	2.663 (4)	2.682 (3)	2.728 (6)
O1-O3A2	2.667 (5)	2.689 (3)	2.739 (6)
O2-O3	2.661 (4)	2.670 (3)	2.711 (6)
O2-O3A2	2.570 (4)	2.588 (3)	2.614 (6)
O3-O3A2	2.648 (3)	2.656 (1)	2.681 (6)
mean of 6	2.658	2.674	2.711
T-TA2	3.099 (3)	3.102 (1)	3.131
O1-T-O2	117.9 (2)	117.6 (1)	117.3 (2)
O1-T-O3	109.1 (2)	109.6 (1)	110.3 (2)
O1-T-O3A2	108.8 (2)	109.4 (1)	110.3 (2)
O2-T-O3	110.3 (2)	109.7 (1)	109.7 (2)
O2-T-O3A2	104.4 (2)	104.3 (1)	103.6 (2)
O3-T-O3A2	105.6 (1)	105.6 (1)	104.8 (2)
mean of 6	109.4	109.4	109.3
T-O3-TA2	137.5 (2)	136.8 (2)	135.6
O3A2-O3-O3A2 (+1 in c)	168.7 (2)	165.8 (2)	166

^a Nomenclature after Burnham *et al.* (1967); atoms of basic set unless otherwise designated. Errors in parentheses are one standard deviation; for 1.612 (3) read 1.612 ± 0.003 Å. For tetrahedral contents, see Table 9.

^b Values not given in reference were calculated by present authors.

to estimate the Mg, Al, and Fe²⁺ contents in the three remaining *M1* sites. These occupancy values were used as starting parameters for a least-squares refinement of occupancies in which (Mg + Al) content was assigned the scattering factor of Mg and refined against Fe²⁺, using appropriate constraints. Finally, Mg contents were fixed in three *M1* type sites on the basis of this refinement plus consideration of the bond distances, and Fe²⁺ was then refined against Al.

Bond distances are not helpful in assigning Na and Ca contents among *M2* type sites, because these two cations have similar average *M2*-O distances. Therefore, *M2* occupancies were refined from an initial model assigning to each *M2* site a composite (0.5Na + 0.5Ca) atom with an individual isotropic temperature factor of 0.8 Å². Final parameters obtained for the Venezuelan omphacite from these refinements are compared in Table 10 with those of the Californian omphacite, and the bond distances and angles are given in Tables 22 to 24.

The refined *P2* omphacite structures are characterized by a high degree of order in the *M1* octahedral chains, which consist essentially of alternating Al³⁺ and Mg²⁺ octahedra. Clark and Papike (1968) suggested that ordering of the *M1* chains due to the large size difference between Al³⁺ and Mg²⁺ was the chief reason for the formation of clinopyroxenes with the *P2* structure and that the partial order in the *M2* sites (alternating Ca-rich and Na-rich) was a response to the charge distribution in the ordered *M1* chains. This conclusion is confirmed by the present results for the Venezuelan omphacite, in which *M2* occupancies are similar to those observed in the Californian omphacite.

The "ideal" *P2* omphacite may thus be considered as a clinopyroxene in which the *M1* octahedrally coordinated cations are one-half Mg and one-half Al, and the *M2* cations are one-half Ca and one-half Na, *i.e.* Ca_{0.5}Na_{0.5}Mg_{0.5}Al_{0.5}Si₂O₆. The *M1* chains are required by size and charge considerations to be highly ordered, so that the Al octahedra are as far as possible from each other, both along the chains and from chain to chain. Each *M2* polyhedron shares oxygen atoms with three consecutive *M1* octahedra from one *M1* chain. Hence, if one *M2* polyhedron has one Al³⁺ and two Mg²⁺ neighbors, the next *M2* polyhedron will have one Mg²⁺ and two Al³⁺ neighbors. If all *M1* sites contain Al³⁺, as in jadeite, then all *M2* sites must have Na⁺; similarly, if all *M1* sites contain Mg²⁺, as in diopside, all *M2* sites must have Ca²⁺. In the "ideal" *P2* omphacite, then, the *M2* polyhedron with one Al³⁺ and two Mg²⁺ neighbors must have on the average 1/3 Na⁺ and 2/3 Ca²⁺; the *M2* polyhedron with one Mg²⁺ and two Al³⁺ neighbors must have on the average 2/3 Na⁺ and 1/3 Ca²⁺. This is the *maximum* degree of order to be expected, even in "ideal" omphacite. The Californian and Venezuelan omphacites do have a degree of order approaching this maximum.

X-ray diffraction studies cannot distinguish between Fe²⁺ and Fe³⁺ except on the basis of observed bond distances and charge considerations. For the Californian omphacite (Clark and Papike, 1968), Fe was allocated among the four *M1* sites by assuming Fe²⁺ to be associated with Mg²⁺ and Fe³⁺, with Al. The Venezuelan omphacite has so little Fe³⁺ that only Fe²⁺ was considered during refinement, and it is allocated among three *M1* sites (Table 10). Mössbauer spectral studies (Bancroft, Williams, and Essene, 1969) of samples comparable to those from which our omphacite crystals were selected indicate for both samples the presence of Fe²⁺ in four sites that are assumed to be the *M1* type sites. The differences between the X-ray diffraction and Mössbauer results are minor but suggest that further investigation of the partitioning of Fe in a number of *P2* omphacites is necessary in order to determine the nature and significance of the Fe distribution.

Relationship of cell parameters to chemical composition and structure. On the basis of the cell parameters

TABLE 22. COMPARISON OF DISTANCES FOR *M1* TYPE OCTAHEDRA IN TWO *P2* OMPHACITES

Oxygen of <i>M</i> -O	Bond distances (Å) ^a							
	Venezuela Present study ^b				California Clark and Papike (1968) ^c			
	<i>M1</i>	<i>M1</i> (1)H	<i>M1</i> (1)	<i>M1</i> H	<i>M1</i>	<i>M1</i> (1)H	<i>M1</i> (1)	<i>M1</i> H
	Mg 0.82 Fe 0.10 Al 0.08	Mg 0.90 Fe 0.10	Al 1.00	Al 0.92 Fe 0.08	Mg 0.81 Fe 0.19	Mg 0.80 Fe 0.20	Al 0.95 Fe 0.05	Al 0.82 Fe 0.18
O1A1	2.12		1.90		2.12		1.91	
O1A2	2.06		1.96		2.09		2.03	
O1C1		2.06		2.01		2.07		1.97
O1C2		2.13		1.97		2.16		1.99
O2A1				1.88				1.91
O2A2		2.06				2.06		
O2C1	2.00				2.01			
O2C2			1.89				1.88	
Mean	2.06	2.08	1.92	1.96	2.07	2.10	1.94	1.95

^a Each bond occurs twice.

^b 1 standard deviation, 0.01 Å.

^c 1 standard deviation, 0.02 Å.

known at that time, Whittaker (1960) suggested that the ionic size of both *M1* and *M2* cations affects the β value, the major influence being that of *M2* and a "disturbing influence" being due to *M1*. The refined cell parameters currently available (Table 1) indicate that this suggestion is correct. The eight ordered clinopyroxenes can be divided neatly into three *M2* groups: Li clinopyroxenes with β near 110°, Na clinopyroxenes with β near 107.5°, and Ca clinopyroxenes with β near 105.5°.

TABLE 23. COMPARISON OF DISTANCES FOR *M2* TYPE POLYHEDRA IN TWO *P2* OMPHACITES

Oxygen of <i>M2</i> -O	Bond distances (Å) ^a							
	Venezuela Present study ^b				California Clark and Papike (1968) ^c			
	<i>M2</i>	<i>M2</i> (1)H	<i>M2</i> (1)	<i>M2</i> H	<i>M2</i>	<i>M2</i> (1)H	<i>M2</i> (1)	<i>M2</i> H
	Na 0.76 Ca 0.24	0.68 0.32	0.25 0.75	0.31 0.69	0.64 0.36	0.64 0.36	0.36 0.64	0.91 0.97
O1A1	2.34				2.39			
O1A2			2.38	2.40			2.32	2.46
O1C1						2.33		
O1C2		2.37				2.35		
O2A1		2.39						
O2A2				2.40				2.44
O2C1			2.38				2.35	
O2C2	2.34				2.39			
O3A1		2.67		2.51		2.67		2.49
O3A2		2.41		2.80		2.43		2.79
O1C1	2.51		2.75		2.51		2.76	
O1C2	2.72		2.44		2.73		2.48	
Mean of <i>c</i> (shortest)	2.40	2.39	2.40	2.44	2.43	2.37	2.38	2.46
Mean of 81	2.45	2.46	2.49	2.53	2.50	2.44	2.47	2.55

^a Each bond occurs twice.

^b 1 standard deviation, 0.01 Å.

^c 1 standard deviation, 0.02 Å.

The "disturbing influence" of *M1* is slight (less than one degree) within the groups of ordered clinopyroxenes presented here. The intermediate composition clinopyroxenes (Table 2), which all have appreciable Na + Ca in the *M2* site, have β angles of 106.5 to 107°, very nearly halfway between the values found for the ordered Na and Ca groups.

Surprisingly, the length of the *c* dimension in the ordered clinopyroxenes (Table 1) appears to be correlated with the kind and size of the cation occupying the *M1* site. The *c* values range from 5.22 Å for Al in *M1* to 5.29 Å for Fe³⁺ and Mn²⁺ in that site and attain a high of 5.37 Å for the In³⁺ compound. Brown (1960) suggested that the *c*-dimension was unlikely to be affected by factors other than substitution of tetrahedral aluminum for silicon, but the present observations indicate otherwise.

The equation proposed by Clark, Appleman, and Papike (1968) to relate the *b*-dimension to the average *M1*-O distance fits fairly well for the ordered clinopyroxenes, but rather poorly for the intermediate *C2/c* clinopyroxenes. Perhaps this means the equation is applicable only when *M2* is filled with Na and Ca.

CONCLUSIONS

The most important results of the present study are as follows:

1. The bonding in chain silicates is largely ionic in character, and the details of the structures can be explained in terms of an essentially ionic model without invoking additional covalent effects.

2. The charge and size of the *M2* cation are considered responsible for determining the structure type of most pyroxenes, the *P2* omphacites excepted. Large singly or doubly charged *M2* cations lead to the *C2/c* diopside-type

TABLE 24. COMPARISON OF BOND DISTANCES (Å) AND BOND ANGLES (°) FOR THE TETRAHEDRA OF TWO *P2* OMPHACITES*

Atoms	A1 tetrahedron		A2 tetrahedron		C1 tetrahedron		C2 tetrahedron	
	Venezuela ^b	California ^c	Venezuela ^b	California ^c	Venezuela ^b	California ^c	Venezuela ^b	California ^c
Si-O distances								
Oxygen								
O1	1.64	1.63	1.65	1.64	1.59	1.59	1.59	1.60
O2	1.61	1.63	1.55	1.57	1.62	1.60	1.58	1.57
mean, non-brg.	1.62	1.63	1.60	1.60	1.60	1.60	1.59	1.58
O3 (1)	1.65	1.65	1.65	1.66	1.65	1.64	1.65	1.68
O3 (2)	1.66	1.66	1.68	1.70	1.65	1.63	1.66	1.67
mean, brg.	1.65	1.66	1.67	1.68	1.65	1.64	1.65	1.68
mean of 4	1.64	1.64	1.63	1.64	1.63	1.62	1.62	1.63
O-O distances								
O1-O2	2.77	2.80	2.72	2.66	2.76	2.82	2.75	2.73
O1-O3 (1)	2.65	2.66	2.71	2.72	2.61	2.61	2.60	2.66
O1-O3 (2)	2.73	2.71	2.67	2.73	2.64	2.58	2.64	2.64
O2-O3 (1)	2.65	2.66	2.58	2.63	2.65	2.61	2.58	2.66
O2-O3 (2)	2.58	2.57	2.67	2.69	2.56	2.51	2.66	2.61
O3 (1)-O3 (2)	2.66	2.65	2.61	2.64	2.58	2.65	2.69	2.64
mean of 6	2.67	2.67	2.66	2.68	2.63	2.63	2.65	2.66
Si-Si distances								
Si (1)—Si (2)	3.080	3.06	3.098	3.11	3.049	3.07	3.121	3.12
O-Si-O angles								
Oxygens								
O1, O2	117.2	118	116.6	112	119.0	124	120.5	119
O1, O3 (1)	107.6	109	110.5	112	107.4	108	109.2	106
O1, O3 (2)	111.6	111	106.4	109	109.2	107	106.3	108
O2, O3 (1)	108.9	109	113.3	113	108.2	107	110.8	107
O2, O3 (2)	104.1	103	105.5	107	103.4	102	105.6	110
O3 (1), O3 (2)	107.1	106	103.3	104	109.4	109	102.8	103
mean of 6	109.4	109.3	109.3	109.5	109.4	109.5	109.2	108.8
Si-O3-Si angles								
Si (1), Si (2)	135.1	132	139.0	139	141.2	137	135.2	130
O3 (1)-O3 (2)-O3 (1) angles								
A chain				C chain				
Venezuela		California		Venezuela		California		
107.3		165		169.1		165		

* Nomenclature after Burnham *et al.* (1967).

^b Present study; one standard deviation, Si-O, 0.01 Å, O-O, 0.02 Å, Si-Si, 0.007 Å, O-Si-O, 0.6°, Si-O-Si, 0.7°.

^c Clark and Papike (1968); one standard deviation, Si-O and O-O, 0.02 Å, Si-Si, 0.01 Å, angles, 1°.

structure, small singly charged *M2* cations to the *C2* spodumene-type structure, and small doubly charged *M2* cations to the *P2*_{1/c} clinoenstatite-type or orthorhombic structures.

3. The average *M1*-O bond distances found for the ordered clinopyroxenes can be used in linear combination with the ratios of the various *M1* ions present in a disordered clinopyroxene to arrive at expected average *M1*-O values for any particular compositional model.

4. The *T*-O2 distance in disordered *C2/c* clinopyroxenes containing tetrahedral Al appears to vary linearly

with the amount of Al and is a more sensitive indicator than the average *T*-O distance.

5. Ferrous iron is disordered between *M1* and *M2* in two *C2/c* clinopyroxenes of intermediate composition, but ferric iron is ordered entirely in the *M1* site.

6. "Ideal" *P2* omphacite has the formula Ca_{0.5}Na_{0.5}Mg_{0.5}Al_{0.5}Si₂O₆; Mg and Al are fully ordered in *M1* sites, but (Na + Ca) are partially ordered in *M2* sites, the maximum partial ordering being in the Ca:Na ratio of 1:2 or 2:1, alternating between sites.

7. The *c* dimensions of "end-member" clinopyroxenes re-

flect the nature of the chemical species in the *M1* octahedral chains.

8. The silicon and oxygen atoms in "end-member" clinopyroxenes have individual isotropic temperature factors of $0.3 \pm 0.1 \text{ \AA}^2$ and $0.4 \pm 0.1 \text{ \AA}^2$, respectively; these atoms have higher temperature factors in intermediate composition clinopyroxenes.

ACKNOWLEDGMENTS

We appreciate the assistance provided during the course of this study by many colleagues. Dr. Larry W. Finger, Geophysical Laboratory, Washington, D.C., generously made available his computer programs and helped sort out the problems associated with site-occupancy refinements and calculation of thermal ellipsoids. Dr. Stefan S. Hafner, University of Chicago, examined the augite by Mössbauer spectral methods and permitted us to report on his results in advance of publication. Dr. C. T. Prewitt, E. I. du Pont de Nemours Co., Wilmington,

Delaware, provided some computer programs, and Drs. Stewart K. Kurtz and K. Nassau, Bell Telephone Laboratories, Murray Hill, New Jersey, made the harmonic-oscillator analysis of omphacite. Dr. A. T. Anderson, University of Chicago, carried out electron-microprobe studies of the crystals while at the U. S. Geological Survey. Dr. David B. Stewart, U. S. Geological Survey, provided the spodumene and $\text{LiFe}^{2+}\text{Si}_2\text{O}_6$ crystals and relevant data; chemical analyses were made by J. J. Fahey and Joseph I. Dinnin. U. S. Geological Survey, Mrs. Judith A. Konert, U. S. Geological Survey, helped materially with the data processing and cell refinements.

Crystals were also supplied by the following: Dr. Louis Fuchs, Argonne National Laboratory, Chicago (synthetic ureyite); Prof. Charles Milton, George Washington University, Washington, D.C. (acmite); Dr. Clarence S. Ross, U. S. Geological Survey (diopside); Dr. H. H. Schmitt, NASA Manned Spacecraft Center, Houston, Texas (*C2/c* omphacite); Dr. Brian Mason, U. S. National Museum, Washington, D.C. (augite); Dr. Benjamin A. Morgan, U. S. Geological Survey (*P2* omphacite).

Note added in proof: The crystal-structure refinement of a synthetic diopside (L. Schröpfer, 1968, *Neues Jahrb. Mineral. Monatsh.* 1968, 441-453), containing 2.13 ± 0.05 weight percent Ti (0.06 atom Ti per six oxygen atoms) yields T-O bond distances identical within 2 s.d. of those reported here for diopside;

agreement for M-O distances is not as close. Schröpfer concluded that Ti is located in the tetrahedral sites. Comparison with results of our study shows that the observed T-O distances cannot be used to support this conclusion, although his site-occupancy refinement is consistent with the assignment.

REFERENCES

- ALEXANDER, LEROY E., AND GORDON S. SMITH (1964) Single-crystal diffractometry: The improvement of accuracy in intensity measurements. *Acta Crystallogr.* 17, 1195-1201.
- APPLEMAN, DANIEL E., AND HOWARD T. EVANS, JR. (1967) Experience with computer self-indexing and unit-cell refinement of powder data [abstr.]. *Geol. Soc. Amer., Prog. 1967 Ann. Meet., New Orleans* [*Geol. Soc. Amer. Spec. Pap.* 115, 8 (1968)].
- , AND DAVID B. STEWART (1966) Crystal-chemistry of spodumene-type pyroxenes [abstr.]. *Geol. Soc. Amer., Prog. 1966 Ann. Meet., San Francisco* [*Geol. Soc. Amer. Spec. Pap.* 101, 5-6 (1968)].
- , F. R. BOYD, JR., G. M. BROWN, W. G. ERNST, G. V. GIBBS, AND J. V. SMITH (1966) *Short Course on Chain Silicates*. Amer. Geol. Inst., Washington, D.C.
- BANCROFT, G. MICHAEL, AND ROGER G. BURNS (1969) Mössbauer and absorption spectral study of alkali amphiboles. *Mineral. Soc. Amer. Spec. Pap.* 2, 135-148.
- , P. G. L. WILLIAMS, AND ERIC J. ESSENE (1969) Mössbauer spectra of omphacites. *Mineral. Soc. Amer. Spec. Pap.* 2, 59-65.
- BORG, I. Y., AND DEANE K. SMITH (in press) Calculated X-ray powder patterns for the silicate minerals. *Geol. Soc. Amer. Mem.* 122.
- BROWN, G. M. (1960) The effect of ion substitution on the unit cell dimensions of the common clinopyroxenes. *Amer. Mineral.* 45, 15-38.
- BURNHAM, CHARLES W. (1965) Evaluation of thermal parameters for silicon, aluminum and oxygen atoms in silicates [abstr. JA7]. *Amer. Crystallogr. Ass., Prog. Abstr., Gallinburg, Tenn.*
- (1967) Ferrosilite. *Carnegie Inst. Wash. Year Book* 65, 285-290.
- , JOAN R. CLARK, J. J. PAPIKE, AND C. T. PREWITT (1967) A proposed crystallographic nomenclature for clinopyroxene structures. *Z. Kristallogr.* 125, 109-119.
- CHRISTENSEN, A. NORLUND, AND R. GRØNBAEK HAZELL (1967) The crystal structure of $\text{NaIn}(\text{SiO}_3)_2$. *Acta Chem. Scand.* 21, 1425-1429.
- CLARK, JOAN R., AND J. J. PAPIKE (1968) Crystal-chemical characterization of omphacites. *Amer. Mineral.* 53, 840-868.
- , DANIEL E. APPLEMAN, AND J. J. PAPIKE (1968) Bonding in eight ordered clinopyroxenes isostructural with diopside. *Contrib. Mineral. Petrology* 20, 81-85.
- COLEMAN, R. G., D. E. LEE, L. B. BEATTY, AND W. W. BRANNOCK (1965) Eclogites and eclogites: their differences and similarities. *Geol. Soc. Amer. Bull.* 76, 483-508.
- CROMER, DON T. (1965) Anomalous dispersion corrections computed from self-consistent field relativistic Dirac-Slater wave functions. *Acta Crystallogr.* 18, 17-23.
- , AND JOSEPH B. MANN (1968) X-ray scattering factors computed from numerical Hartree-Fock wave functions. *Acta Crystallogr.* A24, 321-324.
- , AND J. T. WABER (1965) Scattering factors computed from relativistic Dirac-Slater wave functions. *Acta Crystallogr.* 18, 104-109.
- CRUICKSHANK, D. W. J. (1961) The role of 3d-orbitals in π -bonds between (a) silicon, phosphorus, sulfur, or chlorine and (b) oxygen or nitrogen. *J. Chem. Soc.* 1961, 5486-5504.
- FINGER, LARRY W. (1969) Determination of cation distributions by least-squares refinement of single-crystal X-ray data. *Carnegie Inst. Wash. Year Book* 67, 216-217.
- FREED, R. L., AND DONALD R. PEACOR (1967) Refinement of the crystal structure of johannsenite. *Amer. Mineral.* 52, 709-720.
- FRONDEL, CLIFFORD, AND CORNELIS KLEIN, JR. (1965) Ureyite, $\text{NaCrSi}_2\text{O}_6$, a new meteoritic pyroxene. *Science* 149, 742-744.
- GHOSE, SUBRATA (1965) Mg^{2+} - Fe^{2+} order in an orthopyroxene, $\text{Mg}_{0.7}\text{Fe}_{0.3}\text{Si}_2\text{O}_6$. *Z. Kristallogr.* 122, 81-99.
- GLUSKER, JENNY PICKWORTH, DICK VAN DER HELM, WARNER E. LOVE, MARILYN C. DORNBERG, JEAN A. MINKIN, CARROLL K. JOHNSON, AND A. L. PATTERSON (1965) X-ray analysis of the substrates of aconitase. VI. The structures of sodium and lithium dihydrogen citrates. *Acta Crystallogr.* 19, 561-572.
- KURTZ, STEWART K., AND T. T. PERRY (1968) A powder tech-

- nique for the evaluation of nonlinear optical materials. *J. Appl. Phys.* 39, 3798-3813.
- MACGILLAVRY, C. H. AND G. D. RIECK (1962) *International Tables for X-Ray Crystallography, Vol. 3*. The Kynoch Press, Birmingham.
- MASON, BRIAN (1966) Pyrope, augite and hornblende from Kakanui, New Zealand. *N. Z. J. Geol. Geophys.* 9, 474-480.
- MCDONALD, W. S., AND D. W. J. CRUICKSHANK (1967) A reinvestigation of the structure of sodium metasilicate, Na_2SiO_5 . *Acta Crystallogr.* 22, 37-43.
- MORGAN, BENJAMIN A. (1967) *Geology of the Valencia Area, Carabobo, Venezuela*. Ph.D. thesis, Princeton Univ., 220 pp.
- MORIMOTO, NOBUO, AND NECIP, GÜVEN (1968) Refinement of the crystal structure of pigeonite, $(\text{Mg}_{0.2}\text{Fe}_{0.8}\text{Ca}_{0.0})\text{SiO}_3$. *Carnegie Inst. Wash. Year Book.* 66, 494-497.
- , DANIEL E. APPLEMAN, AND HOWARD T. EVANS, JR. (1960) The crystal structures of clinoenstatite and pigeonite. *Z. Kristallogr.* 114, 120-147.
- NOLAN, J., AND A. D. EDGAR (1963) An X-ray investigation of synthetic pyroxenes in the system acmite-diopside-water at 1000 kg/cm² water-vapour pressure. *Mineral. Mag.* 33, 625-634.
- PANT, A. K., AND D. W. J. CRUICKSHANK (1967) A reconsideration of the structure of datolite, $\text{CaBSiO}_4(\text{OH})$. *Z. Kristallogr.* 125, 286-297.
- , AND ——— (1968) The crystal structure of α - $\text{Na}_2\text{Si}_2\text{O}_7$. *Acta Crystallogr.* B24, 13-19.
- PAPIKE, J. J., AND JOAN R. CLARK (1968) The crystal structure and cation distribution of glaucophane. *Amer. Mineral.* 53, 1156-1173.
- , MALCOLM ROSS, AND JOAN R. CLARK (1969) Crystal-chemical characterization of clinoamphiboles based on five new structure refinements. *Mineral. Soc. Amer. Spec. Pap.* 2, 117-136.
- PAULING, LINUS (1929) The principles determining the structure of complex ionic crystals. *J. Amer. Chem. Soc.* 51, 956-975.
- PEACOR, D. R. (1967) Refinement of the crystal structure of a pyroxene of formula $\text{M}_1\text{M}_{II}(\text{Si}_{1-x}\text{Al}_x)_2\text{O}_6$. *Amer. Mineral.* 52, 31-41.
- PREWITT, C. T., AND CHARLES W. BURNHAM (1966) The crystal structure of jadeite, $\text{NaAlSi}_2\text{O}_6$. *Amer. Mineral.* 51, 956-975.
- , AND DONALD R. PEACOR (1964) Crystal chemistry of the pyroxenes and pyroxenoids. *Amer. Mineral.* 49, 1527-1542.
- SCHMITT, H. H. (1963) *Petrology and Structure of the Eiksundsdal Eclogite Complex, Hareidland, Sunmore, Norway*. Ph.D. thesis, Harvard Univ.
- SMITH, J. V. (1954) A review of the Al-O and Si-O distances. *Acta Crystallogr.* 7, 479-481.
- , AND S. W. BAILEY (1963) Second review of Al-O and Si-O tetrahedral distances. *Acta Crystallogr.* 16, 801-811.
- SOLOV'eva, L. P., AND V. V. BAKAKIN (1967) X-ray study of the sodium-iron metagermanate $\text{NaFeGe}_2\text{O}_6$ [in Russian]. *Kristallografiya* 12, 591-594. [Eng. transl., *Soviet Phys.-Crystallogr.* 12, 517-520 (1968).]
- WARNER, JEFFREY (1964) X-ray crystallography of omphacite. *Amer. Mineral.* 49, 1461-1467.
- WARREN, B. E., AND J. BISCOE (1931) The crystal structure of the monoclinic pyroxenes. *Z. Kristallogr.* 80, 391-401.
- , AND W. LAWRENCE BRAGG (1928) XII. The structure of diopside, $\text{CaMg}(\text{SiO}_3)_2$. *Z. Kristallogr.* 69, 168-193.
- WHITTAKER, E. J. W. (1960) Relationship between the crystal chemistry of pyroxenes and amphiboles. *Acta Crystallogr.* 13, 741-742.
- ZACHARIASEN, W. H. (1963) The crystal structure of monoclinic metaboric acid. *Acta Crystallogr.* 16, 385-392.
- ZUSSMAN, J. (1968) The crystal chemistry of pyroxenes and amphiboles, 1. Pyroxenes. *Earth-Sci. Rev.* 4, 39-67.