

LINDGRENITE, A NEW MINERAL

CHARLES PALACHE, *Harvard University, Cambridge, Mass.*

SUMMARY

Lindgrenite is monoclinic, holohedral. $a:b:c=0.5941:1:0.5124$; $\beta=92^\circ 12'$. The crystals are green and transparent, tabular parallel to (010), which is a perfect cleavage. Unit cell: $a_0=8.45$, $b_0=14.03$, $c_0=7.04$; $\beta=92\frac{1}{2}^\circ$; containing $\text{Cu}_{12}(\text{MoO}_4)_8\text{H}_2\text{O}$, $\text{H}=4\frac{1}{2}$. $G=4.26$. Biaxial negative; $s=b$; $X:c=7^\circ$ in the acute angle β . $\alpha=1.930$, $\beta=2.002$, $\gamma=2.020$; $2V=71^\circ$; $r>v$. Analysis: $\text{CuO } 40.62$, $\text{MoO}_3 \ 50.97$, $\text{H}_2\text{O } 3.30$, $\text{Fe}_2\text{O}_3 \ 1.43$, Insol. 3.34; Sum 99.66; giving $2\text{CuMoO}_4 \cdot \text{Cu}(\text{OH})_2$. Soluble in HCl and in HNO_3 . Occurs in veinlets in limonitic quartz from Chuquicamata, Chile. Named in honor of Professor Waldemar Lindgren.

The mineral described in this paper was found in a collection of ore specimens made from the oxidized zone of the great copper deposit of Chuquicamata, Chile, by Mr. M. C. Bandy, who brought them to the Harvard Mineralogical Laboratory for study. There are two specimens only in the collection: one, massive platy material interspersed in a mass of hematite; the other, a vein in limonitic quartz with many crystal-lined cavities. The crystals are in the

TABLE 1
LINDGRENITE. TWO-CIRCLE MEASUREMENTS

Forms	Crystals	Faces	Mean		Range		Quality	
			ϕ	ρ	ϕ	ρ		
<i>c</i>	001	8	8	90°00'	2°15'	—	2°09'—2°18'	Fair
<i>b</i>	010	14	28	0 00	90 00	—	—	Good
<i>a</i>	100	14	28	90 00	90 00	—	—	Excellent
<i>k</i>	120	1	1	40 32	90 00	—	—	Poor
<i>m</i>	110	3	4	59 18	90 00	58°41'—60°19'	—	Fair
<i>n</i>	210	3	4	73 07	90 00	72 39—73 39	—	Fair
<i>h</i>	012	3	5	8 24	14 39	7 56—9 31	14°20'—14°49'	Poor
<i>e</i>	$\bar{1}01$	1	2	—90 28	39 31	90 00—90 28	39 30—39 31	Poor
<i>p</i>	111	1	2	60 03	46 14	59 57—60 09	—	Very poor
<i>q</i>	$\bar{1}13$	3	5	—56 05	16 57	—55 32—56 37	16 45—17 15	Poor
<i>o</i>	$\bar{1}11$	4	6	—58 09	44 11	57 58—58 18	44 04—44 14	Fair
<i>r</i>	121	12	22	41 18	53 47 $\frac{1}{2}$	41 08—41 28	53 31—53 58	Excellent
<i>s</i>	$\bar{1}21$	1	2	—38 42	52 51	38 37—38 46	52 48—52 54	Poor
<i>t</i>	$\bar{1}31$	9	15	—28 13 $\frac{1}{2}$	60 10	28 07—28 23	59 58—60 21	Excellent

TABLE 2
LINDGRENITE. ANGLE-TABLE

Monoclinic, holohedral.

$$a:b:c=0.5941:1:0.5124; \beta=92^{\circ}12'$$

$$p_0:q_0:r_0=0.8625:0.5120:1; \mu=87^{\circ}48'$$

$$r_2:p_2:q_2=1.9531:1.6846:1$$

$$p_0'=0.8631, q_0'=0.5124, x_0'=0.0384$$

Forms	ϕ	ρ	ϕ_2	$p_2=B$	C	A
<i>c</i> 001	90°00'	2°12'	87°48'	90°00'	0°00'	87°48'
<i>b</i> 010	0 00	90 00	90 00	0 00	90 00	90 00
<i>a</i> 100	90 00	90 00	0 00	90 00	87 48	0 00
<i>k</i> 120	40 06½	90 00	0 00	40 06½	88 35	49 53½
<i>m</i> 110	59 18	90 00	0 00	59 18	88 06½	30 42
<i>n</i> 210	73 28	90 00	0 00	73 28	87 53½	16 32
<i>h</i> 012	8 31½	14 31½	87 48	75 38½	14 21½	87 52
<i>e</i> 1̄01	-90 00	39 31	-50 29	90 00	41 43	129 31
<i>p</i> 111	60 23	46 02½	47 58	69 10	44 08	51 35½
<i>q</i> 1̄13	-55 35	16 49	-76 00	80 35½	18 40	103 48½
<i>o</i> 1̄11	-58 09	44 09½	-50 29	68 26	46 02	126 16½
<i>r</i> 121	41 20½	53 46½	47 58	52 43½	52 20	57 48½
<i>s</i> 1̄21	-38 49½	52 45½	-50 29	51 40	54 09½	119 56½
<i>t</i> 1̄31	-28 13	60 10½	-50 29	40 08½	61 14	114 13

main thin plates, with brilliant facets on their edges. The plates reach a maximum diameter of about 4 mm.; many are much smaller and they are all very thin. They are perfectly transparent and of a green color, deep green in the thicker tablets, yellow-green in the thinner ones.

The monoclinic character is not at first apparent, since most of the crystals show under the lens a pseudo-orthorhombic symmetry, illustrated in figure 1. Measurement of the crystals, however, reveals a distribution of forms which, as exhibited in the stereographic projection, figure 6, establishes their monoclinic symmetry. Fourteen crystals were measured with the results shown in table 1. The choice of the vertical zone was determined by the invariable presence of a pair of faces of perfect quality at right angles to the dominant pinacoid (010). This was selected as the orthopinacoid (100). A face, generally small but of good average quality, was found to lie in the orthodome zone at an angle of 87°45' to the

orthopinacoid and, when this was taken as the basal pinacoid, the other forms present gave a symmetrical distribution about the vertical axis. Besides these pinacoidal forms only two others are prominently developed. These are pyramids giving excellent measurements which lead to the symbols (121) and $(\bar{1}31)$. The elements were calculated from these five forms, and from these elements were derived the angles in table 2.

As shown in table 3, the agreement of the calculated and measured position angles for the principal forms is highly satisfactory.

TABLE 3
LINDGRENITE. CALCULATED AND MEASURED ANGLES

Forms	Calculated		Measured		Faces	Crystals
	ϕ	ρ	ϕ	ρ		
<i>c</i> 001	90°00'	2°12'	90°00'	2°15'	8	8
<i>b</i> 010	0 00	90 00	0 00	90 00	28	14
<i>a</i> 100	90 00	90 00	90 00	90 00	28	14
<i>r</i> 121	41 20	53 46½	41 18	53 47½	22	12
<i>t</i> $\bar{1}21$	-28 13	60 10½	-28 13½	60 10	15	9

For the other forms, most of which were developed either as very narrow line faces or as minute dots, the measurements were less satisfactory; in general, however, they are in good agreement with the calculated angles. The variation from the mean of all measured angles for each form is shown in table 1.

The range of habit is shown in the figures. A tabular habit parallel to (010) is predominant, and generally there is an elongation more or less pronounced in the direction of the vertical axis. Doubly terminated crystals, as shown in figures 2 and 3, are rare; for the most part the crystals are attached to the cavity walls by a surface normal to the vertical axis. The very smallest crystals are slender needles of square cross section, and these often show a pronounced monoclinic termination as illustrated in figure 4. Another feature revealing monoclinic symmetry is a striation, generally visible on the clinopinacoid, which is parallel to the edge of the negative pyramid. This striation sometimes merges into a gentle curved surface inclined to the pinacoid but a few degrees

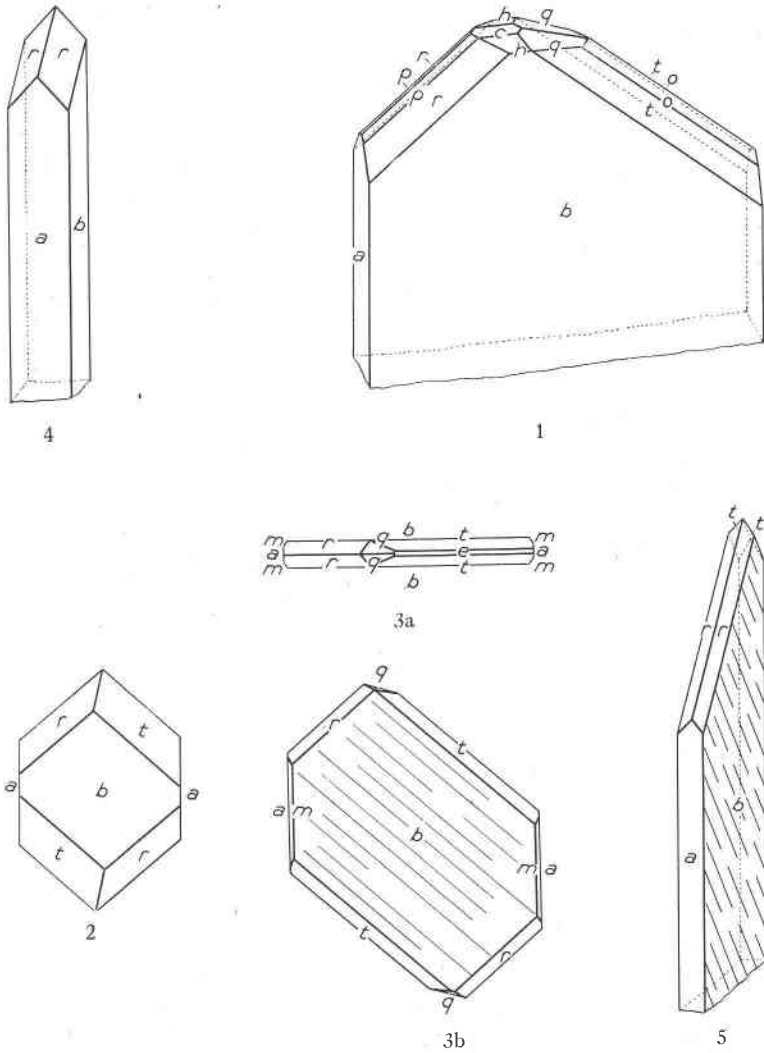

Figs. 1-5. Crystals of lindgrenite.

and regarded as a vicinal development of that form. One measurement yielded the symbol $(\bar{1}.21.1)$.

	φ	ρ
$(\bar{1}.21.1)$ measured	$4^{\circ}22'$	$84^{\circ}41'$
calculated	$4\ 23$	$84\ 42$

The prism zone, except for the two pinacoids b and a , is very weakly developed. The three prism forms listed were observed on but few crystals and always as line faces.

The clinodome $h(012)$ generally accompanies the base c , but on one or two crystals replaces that form and on others is lacking.

The orthodome $e(\bar{1}01)$ and the pyramids $o(\bar{1}11)$ and $s(\bar{1}21)$ form a zone of line faces between the two faces of the dominant negative pyramid $t(\bar{1}31)$. None of them is prominent on the crystals.

Similarly the positive pyramid $p(111)$ is a weak line form beveling the edge between two faces of the strong form $r(121)$.

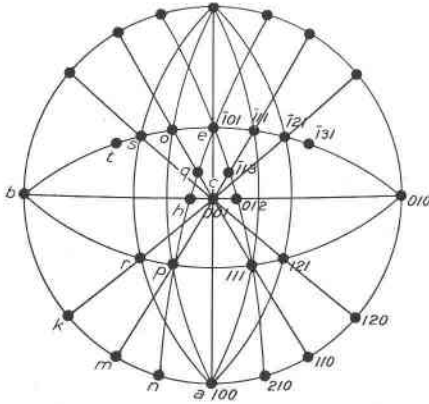

FIG. 6. Stereographic projection of the forms of lindgrenite.

The negative pyramid $q(\bar{1}13)$ was found on several crystals with distinct faces but so minute as to give poor measurements.

It was found that either $r(121)$ or $t(\bar{1}31)$ may be present without the other and, unless the striation above mentioned parallel to the edge of t was visible, it is impossible without measurement to distinguish them. Either one gives rise occasionally to a pronounced monoclinic development of the plates as shown in figures 3 and 5. The crystal drawings are the work of Dr. M. A. Peacock.

Table 4 gives the combinations seen on the measured crystals. Twinning was not observed.

X-RAY MEASUREMENTS:—The dimensions of the structure cell were determined by Mr. Berman. Weissenberg photographs of the

TABLE 4

LINDGRENITE. COMBINATIONS OF FORMS														
	<i>c</i>	<i>b</i>	<i>a</i>	<i>k</i>	<i>m</i>	<i>n</i>	<i>h</i>	<i>e</i>	<i>p</i>	<i>q</i>	<i>o</i>	<i>r</i>	<i>s</i>	<i>l</i>
1	x	x	x	—	—	—	—	—	—	—	x	x	—	x
2	x	x	x	—	—	—	—	—	x	—	x	x	—	x
3	x	x	x	—	—	—	x	—	x	x	x	x	—	x
4	x	x	x	—	—	x	—	—	—	—	—	x	—	—
5	—	x	x	—	—	—	—	—	—	—	—	x	—	x
6	x	x	x	x	—	x	—	—	—	x	—	x	—	x
7	x	x	x	—	—	—	x	—	—	x	x	x	—	x
8	—	x	x	—	x	—	—	x	—	x	—	x	—	x
9	—	x	x	—	x	—	x	—	—	x	x	x	—	x
10	x	x	x	—	—	—	x	x	x	x	—	x	—	x
11	—	x	x	—	—	—	—	—	—	—	—	x	—	—
12	—	x	x	—	—	—	x	—	—	x	x	x	—	x
13	x	x	x	—	—	—	—	—	x	—	x	x	x	x
14	—	x	x	—	—	—	—	—	—	—	—	x	—	x

zero layer line, with the *b*- and *c*-axes as rotation axes, checked by three rotation photographs, gave the values:

$$a_0 = 8.45 \text{ \AA}, b_0 = 14.03 \text{ \AA}, c_0 = 7.04 \text{ \AA}; \beta = 92\frac{1}{2}^\circ.$$

The ratio of the cell sides:

$$a_0 : b_0 : c_0 = 0.602 : 1 : 0.502; \beta = 92\frac{1}{2}^\circ.$$

is in fair agreement with the more accurate, previously determined morphological axial ratio:

$$a : b : c = 0.5941 : 1 : 0.5124; \beta = 92^\circ 12'$$

The *b*-axis zero layer line photograph shows conclusively that the morphological axial directions are also the most suitable for the structure lattice.

PHYSICAL AND OPTICAL PROPERTIES:—The cleavage of lindgrenite is perfect parallel to (010); very imperfect cleavages were observed parallel to (001) and (101). The hardness is 4½. The specific gravity is 4.26, determined by the pycnometer (Gonyer) and by suspension in Clerici solution (Berman) with identical values. The color is green, ranging from bottle green to yellowish green according to the thickness of the plates. The optical properties were determined by immersion in melts by Mr. Bandy and checked by Professor Larsen. Better values, as given below, were obtained by Mr. Berman, using new liquids of unusually high refractive index.

<i>X</i> : <i>c</i> -axis = 7° in the acute angle β.	$\left. \begin{array}{l} \alpha = 1.930 \\ \beta = 2.002 \\ \gamma = 2.020 \end{array} \right\} \pm 0.003$	Negative 2 <i>V</i> = 71° <i>r</i> > <i>v</i>
<i>Z</i> = <i>b</i> -axis		

CHEMICAL COMPOSITION:—A sample of about 1.5 grams was purified by eliminating quartz, as far as possible, with the magnet. The analysis as shown below yields the formula $2\text{CuMoO}_4 \cdot \text{Cu}(\text{OH})_2$.

ANALYSIS OF LINDGRENITE BY F. A. GONYER

	1	2	3
CuO	40.62	42.8	43.8
MoO ₃	50.97	53.7	52.9
H ₂ O	3.30	3.5	3.3
Fe ₂ O ₃	1.43		
Insoluble (SiO ₂)	3.34		
	99.66	100.0	100.0

1. Analysis of lindgrenite. The water was determined on a purer sample than was used for the remaining constituents.

2. Calculated to 100% after removal of 1.43% ferric oxide and 3.34% insoluble (SiO₂) considered as impurities.

3. Theoretical values for $2\text{CuMoO}_4 \cdot \text{Cu}(\text{OH})_2$.

The molecular weight of the contents of the unit cell (M) was determined by Mr. Berman from the formula, $M = Vd/A$, where V is the volume of the unit cell (834×10^{-24} c.c.), d is the density (4.26 gm./c.c.), A is the reciprocal of Avogadro's number (1.65×10^{-24}). Whence M is 2154. The following table gives, in terms of oxides, the number of atoms in the unit cell, obtained from M and the found percentage weights of the oxides reduced to 100 per cent.¹

	Per cent	Mol. ratio	$M \times \text{mol. ratio}/100$
CuO	42.8	0.538	11.6
MoO ₃	53.7	0.373	8.0
H ₂ O	3.5	0.194	4.2

Assuming that the numbers in the last column represent the integers 12, 8, 4, respectively,² the composition of the unit cell is $12\text{CuO} \cdot 8\text{MoO}_3 \cdot 4\text{H}_2\text{O}$, or $4[2\text{CuMoO}_4 \cdot \text{Cu}(\text{OH})_2]$, or better, $\text{Cu}_{12}(\text{MoO}_4)_8\text{H}_8\text{O}_8$, which presupposes no definite arrangement beyond a very probable linking of each atom of Mo with four atoms of O in the acid radicle.

¹ F. A. Bannister and M. H. Hey, *Mineral. Mag.*, vol. 22, p. 575, 1931.

² The differences are due to the combined errors in the determination of the cell dimensions, density and chemical composition.

Lindgrenite is the first molybdate of copper as yet found as a mineral, and neither in form nor in composition can it be grouped with any known natural substance.

PYROGNOSTICS:—Alone on charcoal lindgrenite melts easily, gives a strong reaction for copper when touched with HCl, and reduces to a copper bead. In the closed tube it darkens quickly, decrepitates slightly, giving a slight brownish coating on the wall of the tube near the assay, and melts. There is a fairly abundant deposit of neutral water. It is easily and completely soluble in both HCl and HNO₃; the solution when boiled to dryness and again taken up with acid leaves an abundant heavy white residue of MoO₃, insoluble on boiling; the nature of this residue was first established by a spectrogram for which I am indebted to Dr. G. A. Harcourt.

The author takes great pleasure in designating this well-defined mineral lindgrenite in honor of Professor Waldemar Lindgren. His great contributions to the knowledge of the mineralogy of the ore deposits and their paragenesis makes it peculiarly fitting that his name should appear in the special literature of mineralogy.