

# GOLDICHITE, A NEW HYDROUS POTASSIUM FERRIC SULFATE FROM THE SAN RAFAEL SWELL, UTAH\*

A. ROSENZWEIG, *University of Minnesota, Minneapolis, Minnesota*, †

AND

EUGENE B. GROSS, *Exploration Division, U. S. Atomic Energy Commission, Grand Junction, Colorado*.

## ABSTRACT

Goldichite, a new hydrous potassium ferric sulfate from the Dexter No. 7 Mine, Calf Mesa, San Rafael Swell, Utah, has the composition  $KFe(SO_4)_2 \cdot 4H_2O$ . It occurs as radiating clusters of pale-green crystals or fine-grained crystalline encrustations. It is associated with coquimbite, halotrichite, roemerite, alunogen, copiapite, fibroferrite, melanterite and other sulfates, which comprise the cementing material of a talus slope below a small, pyrite-rich uranium deposit in the Triassic Shinarump conglomerate. Crystals are commonly singly terminated, monoclinic-prismatic laths parallel {100} with forms {100}, {110}, and {011}. The space group is  $P2_1/c$  and the cell constants are:  $a_0=10.45 \text{ \AA}$ ,  $b_0=10.55 \text{ \AA}$ ,  $c_0=9.15 \text{ \AA}$ ,  $\beta=101^\circ 49'$ . The cell contains 4 molecules; the density is 2.43 (observed) and 2.419 (calculated). The mineral is biaxial positive, with  $2V=82^\circ$  (calculated),  $\alpha=1.582$ ,  $\beta=1.602$ ,  $\gamma=1.629$ ;  $X=b$ ,  $Z \wedge c=11^\circ$ .

The mineral is named in honor of Samuel S. Goldich, Professor of Geology at the University of Minnesota.

## INTRODUCTION

The new mineral goldichite, a hydrous potassium ferric sulfate, was first observed in a suite of sulfate minerals from the Dexter No. 7 Mine, Calf Mesa, San Rafael Swell, Utah, submitted to the authors for identification by R. L. Akright of the Atomic Energy Commission. The large number of unusual minerals in this suite prompted the authors to visit the locality early in 1953. A large number of samples were collected, including several of the suspected new mineral. Additional specimens were collected by John W. Gruner and Deane K. Smith, Jr., of the University of Minnesota during the summer of 1953.

The Dexter No. 7 Mine is located along the southeast rim of Calf Mesa, which is in the northwestern end of the San Rafael Swell in Emery County, Utah. The locality is approximately 30 miles west of Greenriver, Utah, as shown in the index map (Fig. 1). The mine is owned by Harold Olsen, Nolan Olsen and Leonard Wilson, who have operated it intermittently for its uranium content. At the time of the authors' visit the property was not being operated, and previous mining activity did not appear to have been extensive.

The mineral is named in honor of Dr. Samuel S. Goldich, Professor

\* Work done by and on behalf of the Raw Materials Division, U. S. Atomic Energy Commission.

† Formerly with U. S. Atomic Energy Commission, Grand Junction, Colorado. Present address, Dept. of Geology, University of New Mexico, Albuquerque, New Mexico.

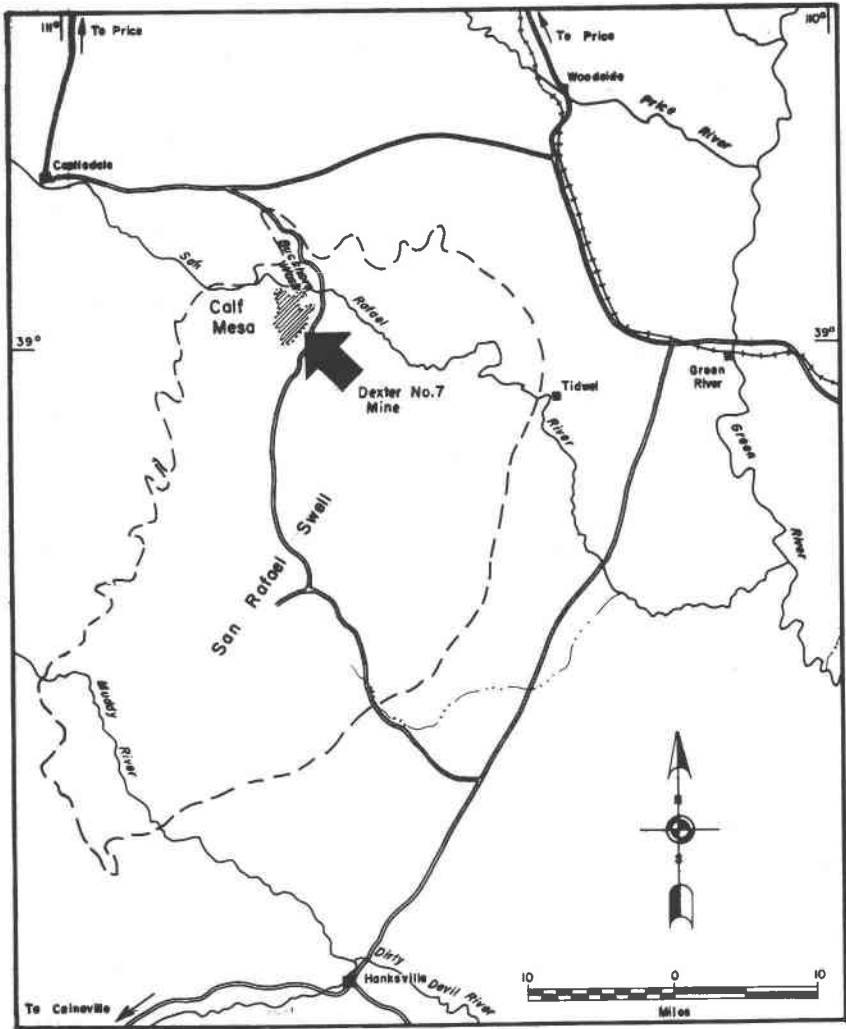

FIG. 1. Index map of Dexter No. 7 Mine and San Rafael Swell, Utah. (Drafted by Exploration Division, U. S. Atomic Energy Commission, Grand Junction, Colorado).

of Geology at the University of Minnesota, in recognition of his contributions to mineralogy and petrology, both in teaching and directing the Rock Analysis Laboratory at the University of Minnesota.

#### OCCURRENCE

The Dexter No. 7 deposit is in the Triassic Shinarump conglomerate which caps Calf Mesa. The ore horizon is about 25 feet above the contact

of the Shinarump and the underlying Moenkopi formation (Akright, 1953). The shales and mudstones of the Moenkopi formation form a steep slope below the Shinarump cliff. Directly below the ore horizon, and extending down over the Moenkopi slope, is a talus breccia composed of fragments of the Shinarump conglomerate. The talus is crusted over with fine-grained material making it almost indistinguishable from the Moenkopi slope. A trench has been cut into this talus directly below the workings, and it is here that the sulfates are found cementing the talus fragments. The minerals of this suite, in addition to goldichite, are coquimbite, halotrichite, roemerite, alunogen, copiapite, melanterite, fibroferrite, voltaite, butlerite, parabutlerite, chalcantinite and diadochite. The essential minerals of the uranium deposit are metazeunerite, pyrite and chalcopyrite. The greatest percentage of the uranium is found in an asphalt-like carbonaceous material of indeterminate nature, where in it may be present as extremely minute grains of uraninite as is common in other deposits in the San Rafael Swell (Rosenzweig, Gruner and Gardiner, 1954, p. 351).

Goldichite occurs as small laths in radiating clusters and as encrustations of very minute crystals in the near surface zone of the talus. It is closely associated with platy masses of white alunogen, purple crystals of coquimbite and bright yellow, small crystals of copiapite.

#### CRYSTALLOGRAPHY

Crystals of goldichite are small laths elongated parallel to the  $c$ -axis [001], and flattened parallel to the orthopinacoid {100}. The prism {110} and clinodome {011} are present on all crystals, and are nearly ideal in their development. Most crystals are singly terminated, but some, especially the minute ones making up the encrustations, are doubly terminated. The larger crystals have striated prism zones, while the smaller ones show smooth, highly reflecting faces. Single crystals range in size up to 2.5 mm. parallel to  $c$ , 1.0 mm. parallel to  $b$ , and 0.4 mm. parallel to  $a$ . Crystals up to 4 mm. in length are found in parallel and radiating growths. Figure 2 shows the natural habit of both the larger and smaller crystals, the latter being almost ideal in their development.

Morphological measurements were made on six crystals. The small number of faces observed makes the determination of crystal class uncertain, but the appearance of the clinodome {011} on both terminations and the presence of a mirror plane strongly suggests the class to be monoclinic-prismatic. This is conclusively borne out by the  $x$ -ray data. Morphological data are given in Table 1. Due to the poor quality of reflections from the striated zone, it was necessary to calculate the crystallographic elements from the  $x$ -ray data. These are given in Table 2.

TABLE 1. MORPHOLOGICAL DATA

Form	No. of Obs.	Quality	Average $\phi$	Average $\rho$
100	12	fair	90°19'	89°52'
120	1	v. poor	29°52'	90°12'
110	20	fair	45°30'	89°55'
210	2	v. poor	62°37'	89°50'
011	17	good	13°43'	41°36'

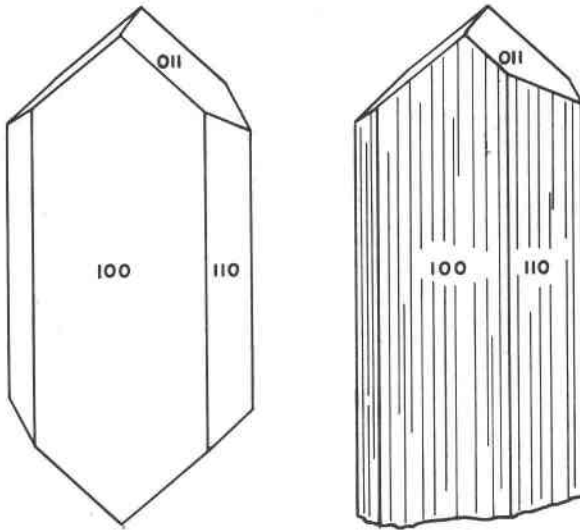

FIG. 2. Goldschichte; nearly ideal development of small crystals (left); habit of the larger crystals (right).

TABLE 2. CRYSTALLOGRAPHIC ELEMENTS AND ANGLE TABLE  
(CALCULATED FROM X-RAY DATA)Monoclinic prismatic— $2/m(C_{2h})$ 

$$a:b:c=0.9924:1:0.8689; \beta=101^{\circ}49'$$

$$p_0:q_0:r_0=0.8755:0.8505:1$$

$$r_2:p_2:q_2=1.176:1.029:1; \mu=78^{\circ}11'$$

$$p_0'=0.8945; q_0'=0.8689; x_0'=0.2092$$

Forms	$\phi$	$\rho$	$\phi_2$	$\rho_2=B$	C	A
100	90°00'	90°00'	0°00'	90°00'	78°11'	0°00'
120	27°14'	90°00'	0°00'	27°14'	84°37'	62°46'
110	45°50'	90°00'	0°00'	45°50'	81°33'	44°10'
210	64°06'	90°00'	0°00'	64°06'	79°23'	25°54'
011	13°42'	41°29'	78°11'	30°47'	59°13'	80°58'

TABLE 3. X-RAY DIFFRACTION DATA

Single crystal data—MoK $_{\alpha}$  radiation; MoK $_{\alpha}$ =0.7107 Å  
 $a_0$ =10.45 Å cell volume=986 Å $^3$   
 $b_0$ =10.53 cell contents 4  
 $c_0$ = 9.15 cell weight=1432.6  
 $\beta$ =101° 49'

Powder diffraction data—FeK $_{\alpha}$  radiation; FeK $_{\alpha}$ =1.9373 Å, camera diam. 57.3 mm.

<i>I</i>	<i>d meas.</i> Å	<i>probable index</i>	<i>d calc.</i> Å
8	10.29	100	10.23
9	7.35	110	7.34
7	6.85	011	6.82
	6.16	111	6.15
4	4.31	121	4.32
6	4.00	121	3.998
1	3.825	102	3.822
		211	3.816
2	3.670	220	3.668
1	3.553	212	3.550
6	3.403	022	3.409
		300	3.408
5	3.247	310	3.243
10	3.068	202	3.070
		222	3.067
4	3.014	302	3.026
	2.945	212	2.948
5	2.856	320	2.860
		032	2.761
1	2.752	132	2.755
		213	2.747
		231	2.665
6	2.656	222	2.652
		321	2.599
	2.595	023	2.597

TABLE 3—(continued)  
Powder diffraction data—FeK $\alpha$  radiation, camera diam. 57.3 mm.

<i>I</i>	<i>d meas.</i> Å	<i>probable index</i>	<i>d calc.</i> Å
		132	2.585
	2.560	400	2.556
		140	2.549
3	2.440	$\bar{4}$ 02	2.445
		330	2.445
1	2.320	$\bar{2}$ 41	2.318
		213	2.317
2	2.273	033	2.274
		042	2.268
		$\bar{1}$ 42	2.265
	2.214	$\bar{4}$ 22	2.218
		241	2.214
	2.156	$\bar{2}$ 42	2.159
		104	2.100
1	2.094	$\bar{1}$ 24	2.098
	2.021*		
1	2.002		
	1.901		
1	1.880		
	1.841		
	1.788		
1	1.763		
	1.714		
1	1.671		

\* Large number of choices renders indexing meaningless.

Agreement between measured and calculated angles is good except for the rare forms {120} and {210}.

Space group and unit cell dimensions were determined from precession photographs using MoK $\alpha$  radiation. Pictures were taken of the 0-, 1-, and 2- level with the *c* axis precessing and the beam parallel to *b*, and of

the 0- level with the  $c$ -axis precessing and the beam parallel to  $a^*$ . Symmetry of the photographs shows the crystals to be monoclinic, and systematic extinctions indicate the space group to be  $P2_1/c$ . Powder photographs were taken using  $\text{FeK}_\alpha$  radiation. Spacings calculated from the cell constants, and measured from the powder photographs are in good agreement. The large number of choices makes the indexing of all but the larger spacings rather uncertain. Both single crystal and powder data are given in Table 3.

#### PHYSICAL PROPERTIES

Goldichite is pale yellowish green in color. By artificial light the crystals assume a distinct lavender tint. This same color phenomenon was observed by the senior author on crystals of the ferric sulfate, kornelite. Goldichite has one excellent cleavage parallel to  $\{100\}$ ; the hardness is approximately 2.5.

The density measured on the Berman balance is 2.43; that calculated from the  $x$ -ray data is 2.419. The optical properties of goldichite are as follows:

$$\left. \begin{aligned} \alpha &= 1.582 \pm 0.002 \\ \beta &= 1.602 \pm 0.002 \\ \gamma &= 1.629 \pm 0.002 \end{aligned} \right\} N_{aD}$$

(+)  $2V = 82^\circ$  (calculated)  
 $X = b$   
 $Z \wedge c = 11^\circ$

#### CHEMICAL PROPERTIES

Goldichite is a hydrous potassium ferric sulfate with formula  $\text{KFe}(\text{SO}_4)_2 \cdot 4\text{H}_2\text{O}$ . The chemical analysis is given in Table 4. Although

TABLE 4

	$\text{KFe}(\text{SO}_4)_2 \cdot 4\text{H}_2\text{O}$	Goldichite	ratios
$\text{K}_2\text{O}$	13.11	12.87	
$\text{Na}_2\text{O}$		0.09	1
$\text{Rb}_2\text{O}$		0.03	
$\text{Fe}_2\text{O}_3$	22.24	22.16	1
$\text{TiO}_2$		0.02	
$\text{Al}_2\text{O}_3$		0.32	
$\text{SO}_3$	44.58	43.65	3.94
$\text{H}_2\text{O}$	20.07	20.35	8.16
Insol.		0.23	
	100.00	99.72	

$\text{MnO}$ ,  $\text{MgO}$ ,  $\text{CaO}$ ,  $\text{SrO}$ ,  $\text{BaO}$ ,  $\text{Cs}_2\text{O}$  each less than 0.01 per cent. S. S. Goldich, analyst.  
 $\text{Rb}_2\text{O}$ ,  $\text{Cs}_2\text{O}$ ,  $\text{Na}_2\text{O}$  by flame spectrophotometer by R. B. Ellestad.

the sample was carefully picked, small amounts of halotrichite and alunogen may have been present. The 0.32% of  $\text{Al}_2\text{O}_3$  and slightly high value for  $\text{H}_2\text{O}$  might be explained by these impurities. An impure sample was tested for  $\text{FeO}$ , and little or none was found. The  $\text{SO}_3$  percentage is very likely a little low. The insoluble residue consists of quartz and clay minerals.

Goldichite is only very slightly soluble in cold water; soluble in hot water with hydrolysis; and readily soluble in dilute mineral acids.

The only closely related mineral is the monohydrate of the same compound, krausite (Foshag, 1931), from which goldichite can be readily distinguished by its physical properties.

#### ASSOCIATED MINERALS

The sulfate minerals found at the Dexter No. 7 Mine comprise the cementing material of the rock fragments in the talus. They range from well crystallized vug fillings to solid crystalline masses completely cementing the rock fragments. The trench exposing these minerals is dug to a depth of perhaps thirty to thirty-five feet measured perpendicular to the slope surface. There is a crude but distinct mineralogical zoning parallel to the slope surface. Figure 3 shows, qualitatively, the distribution and abundance of the various minerals.

Many of the minerals are exceptionally well crystallized and some are sufficiently rare to merit a brief description.

##### *Coquimbite*, $\text{Fe}_2(\text{SO}_4)_3 \cdot 9\text{H}_2\text{O}$

Stout hexagonal prisms of purple coquimbite up to half an inch long are abundant in the upper zone of the deposit. The crystals are modified by large basal pinacoids and small unequally developed pyramidal faces. In some cases these large crystals are encrusted with a thick, sugary mass of very small, colorless coquimbite crystals having well developed pyramidal faces. In slightly deeper zones coquimbite occurs as incomplete, colorless to pale lavender crystals up to one quarter inch in length. The refractive indices are  $\epsilon = 1.546$ ,  $\omega = 1.537$ , and are the same for all of the types.

##### *Alunogen*, $\text{Al}_2(\text{SO}_4)_3 \cdot 18\text{H}_2\text{O}$

Large crystalline plates of colorless to white alunogen are common in the upper zone of the deposit. Some of the plates enclose small clusters of goldichite crystals.

##### *Halotrichite*, $\text{Fe}''\text{Al}_2(\text{SO}_4)_4 \cdot 22\text{H}_2\text{O}$

Long, white, silky fibers of halotrichite are common through most of



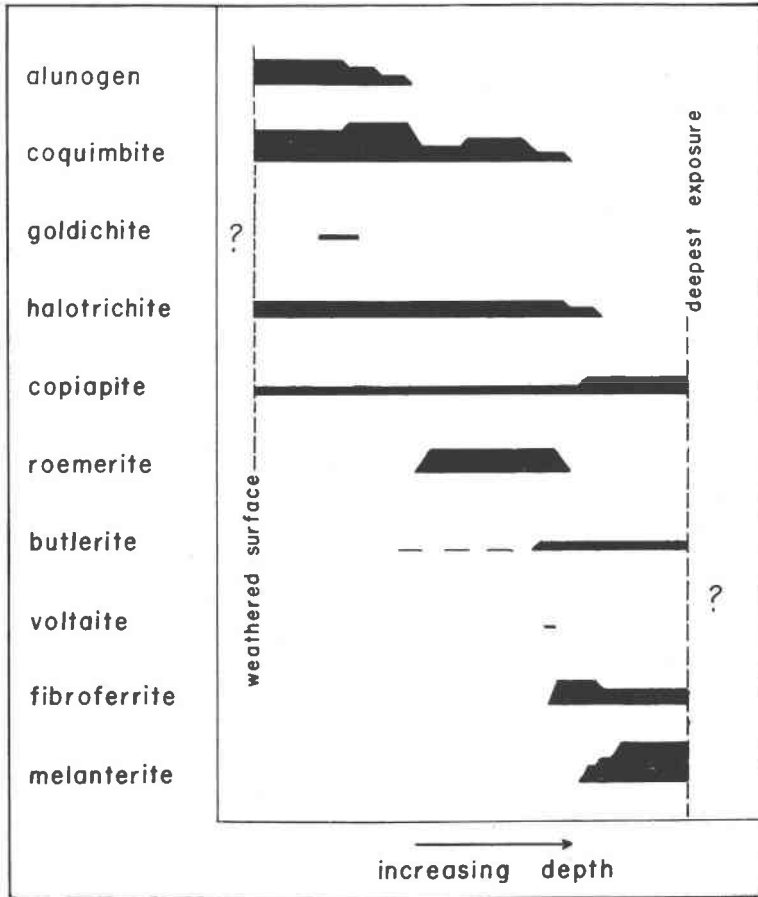

FIG. 3. Relative abundance of minerals in the talus deposit with respect to distance perpendicular to the surface. The abundance representation is qualitative.

the deposit, though almost absent from the deepest exposed zone. Halotrichite fibers are often found growing out of crystals of coquimbite and goldichite. The refractive indices are  $\alpha = 1.481$ ,  $\beta = 1.488$ ,  $\gamma = 1.489$ ; these are at the upper limit for halotrichite and indicate that the amount of magnesium is very small.

*Copiapite*,  $\text{Fe}''\text{Fe}'''(\text{SO}_4)_6(\text{OH})_2 \cdot 20\text{H}_2\text{O}$

Small, brilliant yellow plates of copiapite are common in all zones. The plates are often stacked one upon another in large numbers forming wormy or rod-like structures. The copiapite found in the deepest zone

is extremely sensitive to changes in room temperature and humidity. The crystals become dark, bronzy brown on standing in warm dry air. The color change is reversible and can be made to take place several times before finally becoming permanent. The refractive indices are variable;  $\alpha=1.525-1.530$ ,  $\beta=1.539-1.550$ ,  $\gamma=1.585-1.582$ . The indices suggest that little or no magnesium is present.

*Roemerite*,  $\text{Fe}''\text{Fe}_2'''(\text{SO}_4)_4 \cdot 14\text{H}_2\text{O}$

Crystalline masses and very crude, equant crystals of dark brown roemerite are common in the intermediate zone. The refractive indices are  $\alpha=1.521-1.525$ ,  $\beta=1.567-1.569$ ,  $\gamma=1.577-1.580$ .

*Melanterite*,  $\text{FeSO}_4 \cdot 7\text{H}_2\text{O}$

Melanterite is very abundant in the deepest exposed zone as crystalline masses of pale blue-green to blue color. The color suggests that traces of copper may be present. Melanterite dehydrates very rapidly to  $\text{FeSO}_4 \cdot 4\text{H}_2\text{O}$ .

*Fibroferrite*,  $\text{Fe}(\text{SO}_4)(\text{OH}) \cdot 5\text{H}_2\text{O}?$

Masses of very small, straw yellow, fibrous crystals of fibroferrite are common in the deep zone. Solution pits in melanterite are often lined with fibroferrite crystals a millimeter or two in length, whose surface has an almost metallic luster and color closely resembling that of pyrrhotite.

*Butlerite and Parabutlerite*,  $\text{Fe}(\text{SO}_4)(\text{OH}) \cdot 2\text{H}_2\text{O}$

The dimorphs butlerite and parabutlerite occur as encrustations of small orange crystals with copiapite or melanterite. The two minerals are closely associated and are difficult to separate from one another.

*Voltaite*,  $(\text{K}, \text{Fe}'')_3\text{Fe}'''(\text{SO}_4)_3 \cdot 4\text{H}_2\text{O}?$

Voltaite occurs as black, poorly developed octahedra up to 3 mm. in diameter in a matrix of crystalline coquimbite. Microscopically it is dark olive-green, isotropic, with irregular, weakly anisotropic areas, and a refractive index of 1.603.

*Chalcanthite*

Thin crystalline encrustations of chalcanthite were found close to the slope surface in the upper part of the exposure. This is the only copper mineral observed in the talus deposit; metazeunerite and chalcopyrite are present in the uranium ore horizon.

*Diadochite*,  $\text{Fe}_2(\text{PO}_4)(\text{SO}_4)(\text{OH}) \cdot 5\text{H}_2\text{O}$ 

An orange-brown, amorphous material containing both sulfate and phosphate has been tentatively identified as diadochite. It gives no diffraction pattern, and is isotropic with  $n = 1.622$ .

*Sulfur*

Minute crystals of native sulfur were found closely associated with alunogen, copiapite and goldichite. It is present in very small amounts.

Several other sulfate minerals were found, but were not present in sufficient quantity to permit identification or careful study. Uranium minerals were not observed in the sulfate deposit. A Geiger counter scanning of the exposure indicated only a normal background radiation.

## PARAGENESIS

The occurrence of the large suite of sulfate minerals as a cementing material in a near surface deposit indicates without doubt that surface water was the agent in its formation. Two mechanisms suggest themselves, and very likely both were involved in the deposition. First, surface waters could have traveled through fractures or permeable zones in the pyrite-rich Shinarump conglomerate, oxidized the pyrite, and carried the sulfates in solution along impermeable layers or the top of the Moenkopi to be discharged into the talus, where crystallization took place by evaporation. Second, surface waters could have percolated through the talus composed of pyrite-bearing Shinarump fragments and formed the sulfates in place. Small amounts of pyrite are still to be found in the deeper zones. The fragmentary nature of the talus material suggests that it has been disintegrated by the solution of its cement, possibly pyrite.

A time sequence for the sulfates cannot be established. The system has sufficient components to be quite complex, and the particular phase to crystallize might be very sensitive to both concentration and temperature. Since the deposit is near the surface, and dependent on surface waters for its formation, it is conceivable that stability conditions for any one phase might be attained several times during the history of the deposit. This is exemplified by the intergrowth of the minerals and the several stages of crystallization of some phases (e.g. coquimbite).

The zoning of sulfates and their relative abundance (Fig. 3) shows the near surface zones to be more highly oxidized than the deeper ones. Although both ferric and ferrous iron are found throughout, the latter increases in abundance with depth.

## ACKNOWLEDGMENTS

The authors wish to express their appreciation to R. L. Akright for bringing the occurrence to their attention and for his guidance during their visit to the locality. Thanks are due to J. W. Gruner for his encouragement and for reading the manuscript, and to Wm. N. Lipscomb for his assistance in the single crystal studies. Clifford Frondel kindly supplied type samples of iron sulfate minerals for comparison.

## REFERENCES

- AKRIGHT, R. L., Geology of the Calf Mesa area, Emery County, Utah, with drilling recommendations: *RME-37, U. S. Atomic Energy Commission, 1953*.
- FOSHAG, W. F., Krausite, a new sulfate from California: *Am. Mineral.*, **16**, 351 (1931).
- ROSENZWEIG, A., Mineralogy of the Dexter 7 claim, San Rafael Swell, Utah, and the occurrence of a new potassium iron sulfate mineral; in Gruner, J. W., Rosenzweig, A., and Smith, D. K., Jr., Annual report for April 1, 1953 to March 31, 1954: *U. S. Atomic Energy Commission, April 1954*.
- ROSENZWEIG, A., GRUNER, J. W., AND GARDINER, LYNN, Widespread occurrence and character of uraninite from the Triassic and Jurassic sediments of the Colorado Plateau: *Economic Geology*, **49**, 351 (1954).

*Manuscript received June 21, 1954.*