

The crystal structure of high temperature form of kalsilite (KAlSiO_4) at 950°C

A. KAWAHARA*, Y. ANDOU*, F. MARUMO** and M. OKUNO**

*Department of Earth Sciences, Faculty of Science, Okayama University, Okayama 700, Japan

**Research Laboratory of Engineering Materials, Tokyo Institute of Technology, Nagatsuta, Yokohama 227, Japan

Abstract

The crystal structure of kalsilite at 950°C has been determined by high temperature single crystal methods. In the process of heating, the X-ray powder pattern of kalsilite changes at 865°C , which can be ascribed to the phase transition of this mineral. According to the drastic apparition of the extinction of hkl, 1-odd reflection at 865°C , the space group of kalsilite is assumed to change from P6_3 of the low form to $\text{P6}_3\text{mc}$ of the high form. In order to confirm this structural change, the single crystal structure analysis at 950°C was carried out with an automated four circle diffractometer equipped with an electric furnace. As a result, it was confirmed that kalsilite undergoes a displacive phase transformation at the temperature mentioned above. The high form is hexagonal, $\text{P6}_3\text{mc}$, with $a=5.30(1)$ and $c=8.65(2)\text{\AA}$. Large thermal vibration of $0(1)$ atoms is observed along the direction perpendicular to the bonding of $0(1)$ and Si(Al) atoms. According to the bond distances between $\text{Si(Al)}-0(1)$ atoms, the structure is considered to be partly changed into disordered kalsilite whose space group is $\text{P6}_3/\text{mmc}$. The translation equivalent subgroup relations are found among these three polymorphs, namely P6_3 (low-kalsilite), $\text{P6}_3\text{mc}$ (high-kalsilite) and $\text{P6}_3/\text{mmc}$ (disordered high-kalsilite). In the change of cell dimensions from room temperature to 950°C , there is also one more discontinuous point about at 650°C except that appeared at 865°C . A new phase transition may exist about at 650°C .

Introduction

Kalsilite, KAlSiO_4 , is one of the representative minerals in feldspathoids, whose crystal structure has been assumed to be those having tridymite-like frameworks with reference to the structure of BaAl_2O_4 , KLiSO_4 and nepheline on the basis of the resemblance of cell dimensions and X-ray powder patterns (Claringbull and Bannister, 1948). The structure determination of nepheline was carried out by Buerger, Klein and Donnay (1954).

An accurate structure determination of kalsilite was carried out by Perrota and Smith (1965), who proved that the space group of kalsilite was P6_3 and the structure of kalsilite was derived from that of tridymite by rotating the tetrahedra in the (001)

*Read at annual meeting of the Mineralogical Society of Japan, Tsukuba, 1982.

plane. This refinement confirmed that the silicon and aluminum atoms are ordered on the basis of the tetrahedral distances (T–O), 1.61 and 1.74 Å. Oxygen atoms connecting Si–Al tetrahedra occupy statistically three-fold positions displaced by 0.25 Å from the ideal positions on a triad axis, and the bond angles T–O–T decrease to 163°.

Recently, Dollase and Freeborn (1977) produced kalsilite from nepheline by alkali exchange in molten KCl. They carefully examined the diffraction symmetry, the intensity distribution and the existence of diffuse scattering by means of Weissenberg and precession methods. They observed that intensities of the reflections of the type hhl, with l-odd, were different from one crystal to another. Among the many specimens examined, they found one crystal, in which no hhl, with l-odd reflections were observed. The structure refinement was carried out on this specimens using countermeasured intensity data. The refinement gave essentially same structure as natural kalsilite reported by Perrota and Smith (1965), with ordered tetrahedral Si and Al distributions and oxygen atoms displaced from ideal tridymite-like framework structures. They interpreted that the crystal consists of domains in two orientations related by mirror planes perpendicular to the a-axis with each other, yielding positional disorder for O(2) atoms.

On the analogy of the generation of twins in low quartz, it was assumed that the domain structure of kalsilite was considered to be ascribed to the displacive high-low transition of the structure and the existence of high-low inversion of kalsilite at 875°C was confirmed by means of high temperature X-ray powder methods and the structural model of high temperature form of kalsilite was also presented (Andou and Kawahara, 1982).

Recently Abbott (1984) described the structural relationship among kalsilite groups and presented a short review on the domain structure of kalsilite and the existence of displacive inversion point at 850°C without any references of the works carried out by the previous authors (Dollase and Freeborn, 1977; Andou and Kawahara, 1982).

In order to ascertain the structure of high temperature form of kalsilite, the present authors measured the accurate intensities of the single crystal of synthetic kalsilite with an automated four-circle diffractometer, and the structure of high temperature form was determined at 950°C. At the same time, the change of space group at 875°C was also confirmed using the same diffractometer.

The calculation necessary for this investigation was carried out at the Computer Center of Okayama University using modified programs of UNICS (Sakurai, 1971).

Experimental

The synthesis of kalsilite crystals used for high temperature X-ray experiments was carried out by hydrothermal methods. Starting materials consist of silica gels

(SiO₂), activated alumina (Al₂O₃) and K₂CO₃, which were mixed in kalsilite molecular ratio. K₂CO₃ was added more excessively in various ratios than the stoichiometric amount in the course of several runs. These starting materials were shielded in silver tube with an appropriate amount of dilute K₂CO₃ solutions. The experiments were carried out with the test-tube type apparatus at about 600°C, 1000 kg/cm² from 7 to 15 days. The phase obtained was determined by X-ray powder diffraction measurement and the product was confirmed to be entirely composed of kalsilite powder crystals. These powder specimens were used for the high temperature X-ray powder experiments.

In order to obtain single crystals necessary for intensity measurements, the amount of K₂CO₃ was changed in various ratios and the mixture was cooled from 600°C to 300°C at the rate of 10° per day. The runs have been repeated in various conditions. The crystal habit varies with the degree of the excess of K₂CO₃ in starting materials. The granular-like crystals fitted for X-ray intensity measurements (about 0.2 mm) have finally been obtained with the ratio K₂CO₃:Al₂O₃:SiO₂ = 1.5:1:2 and the cooling rate of temperature 10° per day, from 500° to 450°.

Before single crystal experiments, powder diffraction diagrams were taken at 20, 600, 800 and 1000°C, and the 111 peak disappeared in the diffraction diagram taken at 1000°C. The results are shown in Fig. 1. Also the calculated powder pattern, in which the 111 peak is extinguished, are also shown in Fig. 2 for comparison.

The crystal used for high temperature X-ray intensity measurement has the form of the granular-like hexagonal prism with approximate dimensions 0.2 × 0.2 × 0.2 mm. It was mounted on a silica capillary with zirconia bond. Intensities were measured on an automated four-circle diffractometer equipped with an electric furnace. The temperature of the crystal was raised at the rate of about 13 degrees per hour up to 950°C and kept at 950°C for 12 hours, and it was monitored by a digital voltmeter with Pt–Pt/Rh 13% thermocouple placed at 0.6 mm apart from the crystal. The fluctuation of temperature during the measurement were 8°C at 950°C (Okuno, Marumo and Osaka, 1981).

Intensity data were collected at this temperature using MoK α radiation with a graphite monochromator up to 2θ=80°. The 2θ–ω scan technique was employed with a scanning speed of 2°/min. in 2θ, but there were no observable intensities from 2θ=60° to 80°. Finally, of these intensity data, 115 with I>3σ above background were classified as observed. They were converted to the structure factors by applying Lorentz-polarization corrections. Reflection of 001, l-odd and hhl, l-odd were not observed systematically and the space group was confirmed to be P6₃ mc or P6₃/mmc. The intensities of hhl reflections with l-odd were continuously measured from room temperature up to 950°C, and it was revealed that the reflections lost drastically their intensities at about 865°C.

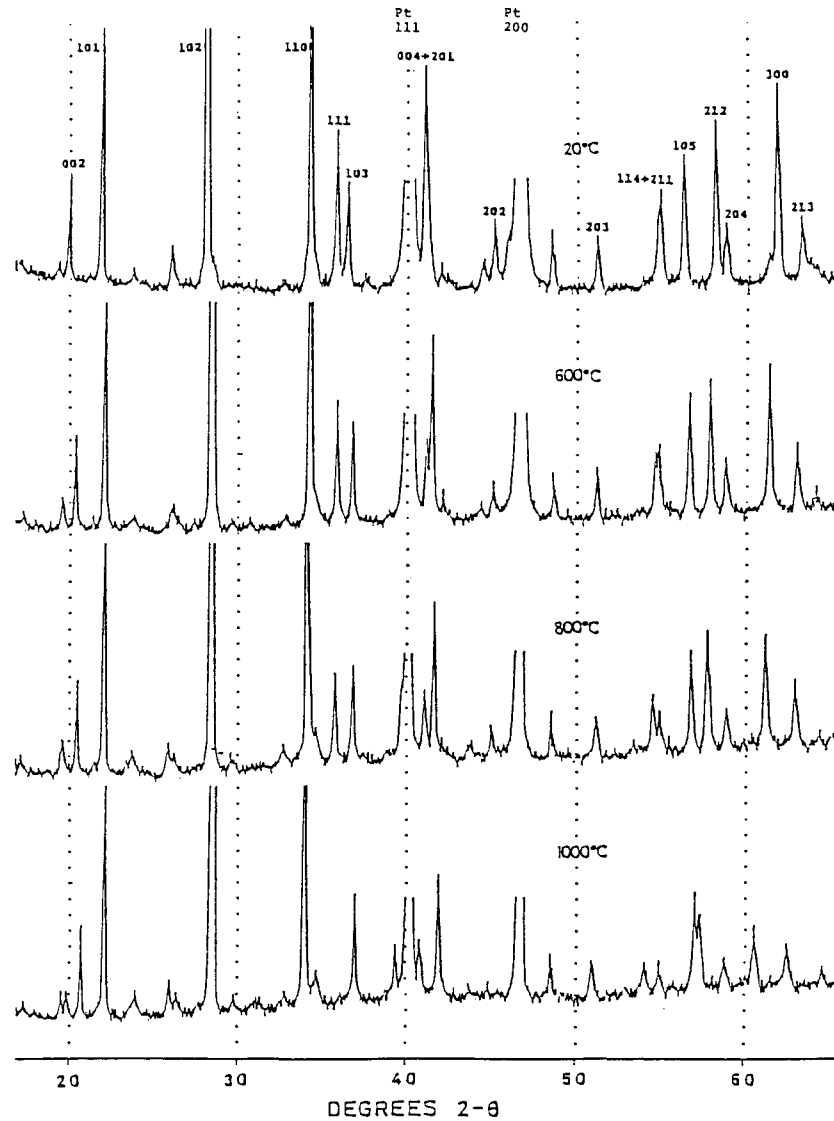

FIG. 1. X-ray powder diffraction diagrams measured at 20, 600, 800 and 1000°C. Some unindexed peaks belong to those of platinum used for the sample holder. The 111 peak disappeared in the diagram measured at 1000°C.

Cell dimensions

The cell dimensions were determined at 25, 209, 400, 600, 795, 850, 900 and 950°C by the same four circle diffractometer. Reflections used for the calculation

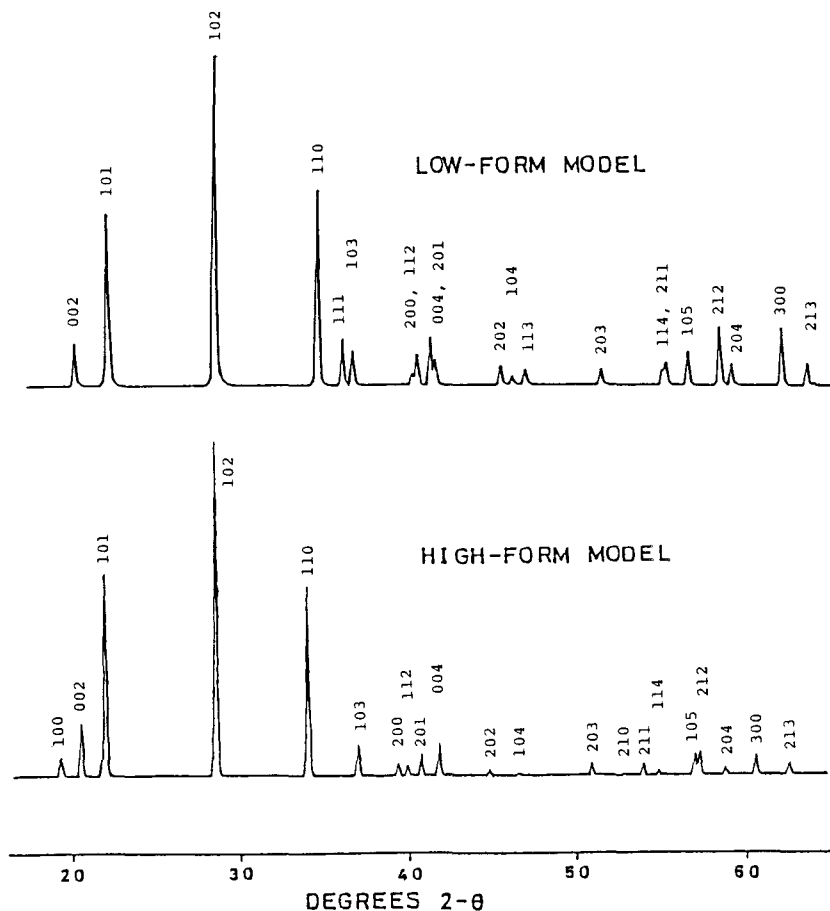

FIG. 2. The calculated powder patterns of low- and high-temperature forms of kalsilite drawn by a computer. The 111 peak disappeared in the high form pattern.

were $00\bar{2}$, $00\bar{2}$, 101 , $\bar{1}11$, 102 , $\bar{1}02$, 112 , $\bar{1}\bar{1}2$, $1\bar{1}\bar{2}$, 212 , $1\bar{3}\bar{2}$, $\bar{3}\bar{2}\bar{2}$, $21\bar{2}$, $1\bar{3}\bar{2}$, $\bar{3}\bar{2}\bar{2}$, $21\bar{2}$, $1\bar{3}\bar{2}$, $\bar{3}\bar{2}\bar{2}$, 300 and $3\bar{3}0$. The intensity values for the same reflections were measured on both sides of the symmetrical positions of each reflection. Table 1 lists the cell dimensions at various temperatures.

Fig. 3 is a plot of the values of a , c and V with the increasing temperature. It is obvious that the lines have two break points at about 650 and 850°C . The latter can be recognized to correspond to the inversion point discussed in this study, while the cause of the former is not known at present. It should be noted that the values of a -axis become larger with the raise of temperature corresponding to the thermal expansion, whereas those of c -axis expands up to 650°C but contracts discontinuously above these two points. This fact may be ascribed to the change of the mode of

TABLE 1. Cell dimensions of kalsilite measured at several temperatures.

Temperature (°C)	a(Å)	c(Å)	V(Å ³)
20	5.1521(4)	8.649(4)	198.8 (1)
209	5.1682(5)	8.662(4)	200.4 (1)
400	5.1896(3)	8.663(4)	202.05(6)
600	5.2148(6)	8.674(6)	204.3 (1)
700	5.2306(4)	8.655(3)	205.06(7)
795	5.2569(7)	8.655(5)	207.1 (1)
850	5.2673(6)	8.655(5)	208.0 (1)
900	5.2807(7)	8.629(5)	208.4 (1)

thermal motion of the oxygen atoms O(2) linking the framework along the c-axis.

Determination of the structure

The structure determination of the high temperature form of kalsilite was carried out based on the structure model of high-kalsilite derived from space group consideration and confirmed by X-ray powder method (Andou and Kawahara, 1982). Six cycles of full-matrix least-squares calculation with anisotropic temperature factors reduced the R-value down to 0.095. The rather high value of R was considered to be complicated mode of thermal vibration of each atom.

Final positional parameters and temperature factors of each atom are shown in Table 2, and interatomic distances and angles are listed in Table 3. Scattering factors corresponding to neutral atoms were used for the structure factors calculations (International Tables for X-ray Crystallography, 1974).

Description of the structure and discussion

Fig. 4 shows the (001) projection of the structure of the high temperature form of kalsilite (below), together with those of two mirror equivalents of the low form (upper a, b). The oxygen atoms O(1), which are splitted into two mirror equivalent positions in the low form, become one in the high form above 865°C through displacive phase transformation. On the basis of the T–O distances (1.61 and 1.71 Å), the silicon and aluminum atoms must be ordered in the tetrahedral sites and the space group is determined as P6₃mc. The structure of high temperature form thus obtained is exactly the same as that derived geometrically on the basis of the space group considerations (Andou and Kawahara, 1982).

In order to see the structural features of constituent atoms, the Fourier sections parallel to (001) were calculated. The results are shown in Fig. 5. As shown in the figure, the contours of the electron density of O(1) atoms are elongated in the direction perpendicular to the T–O–T bonds. In fact, the value of B_{eq} of O(1) atoms is 6.7, which corresponds to the very large amplitude of thermal vibration of O(1) atoms

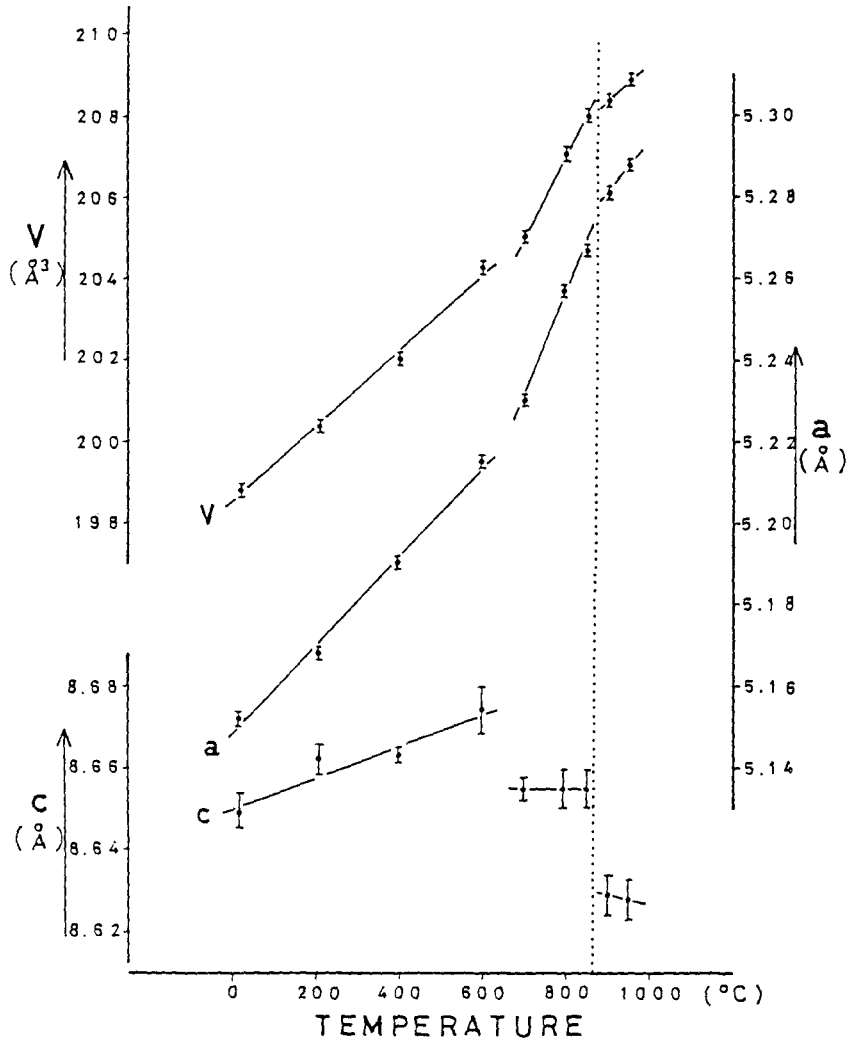

FIG. 3. The diagram showing the relation between the change of heating temperature and lattice dimensions. As shown in the figure, there are two break points in 650°C and 865°C, and the values of *c*-axes change discontinuously at these two points.

along this direction. This abnormal augmentation of thermal vibration seems to be caused by the distortion of T-O-T angles at the transition point. Another oxygen atoms O(2) occupies the off-axial position as in the low form, but the degree of the displacement from the three-fold axis is larger in the high form than in the low form. This displacement of O(2) results in the contraction of the *c*-axis as shown in Fig. 3.

TABLE 2. Atomic parameters of high temperature form of kalsilite at 950°C determined. Isotropic temperature factor was adopted for O(2) atoms.

	X	Y	Z	Beg		
K	0.0	0.0	0.25	9.3(3)		
Al	1/3	2/3	0.058	2.5(2)		
Si	1/3	2/3	0.439(3)	5.6(4)		
O(1)	0.056(6)	0.012(10)	0.984(4)	6.7(7)		
O(2)	0.407(7)	0.741(12)	0.250(6)	—		
	B11	B12	B33	B12	B23	B13
K	0.103(6)	0.103(6)	0.032(2)	0.0	0.0	0.0
Al	0.033(4)	0.033(4)	0.007(1)	0.0	0.0	0.0
Si	0.065(9)	0.065(9)	0.020(2)	0.0	0.0	0.0
O(1)	0.074(18)	0.062(14)	0.029(3)	0.043(11)	-0.007(7)	0.002(6)
O(2)	3.4(6)					

Anisotropic temperature factors of the form

$$\exp [-(B11h^2 + B22k^2 + B33l^2 + 2B12hk + 2B13hl + 2B23kl)]$$

Beq.: calculated using equation, $Beq. = \frac{4}{3}(a^2 B11 + b^2 B22 + c^2 B33 + abB12 \cos \gamma + acB13 \cos \beta + bcB23 \cos \alpha)$

TABLE 3. Interatomic distances and angles of high temperature form of kalsilite at 950°C.

K – O(1)	3.50(3) Å		
K – O(1)'	3.33(4)		
K – O(2)	2.72(6)		
mean K – O	3.12		
Al – O(1)	1.70(4)	O(1) – Si – O(1)'	107.1(1.9)°
Al – O(2)	1.70(6)	– O(2)	123.0(2.7)
		O(1)' – Si – O(2)	111.2(2.9)
mean Al – O	1.70	– O(2)'	100.2(3.1)
Si – O(1)	1.53(4)	O(1) – Si – O(1)'	113.6(1.9)
Si – O(2)	1.68(6)	– O(2)	104.6(2.9)
		O(1)' – Si – O(2)	116.4(2.8)
mean Si – O	1.57	– O(2)'	93.2(3.1)

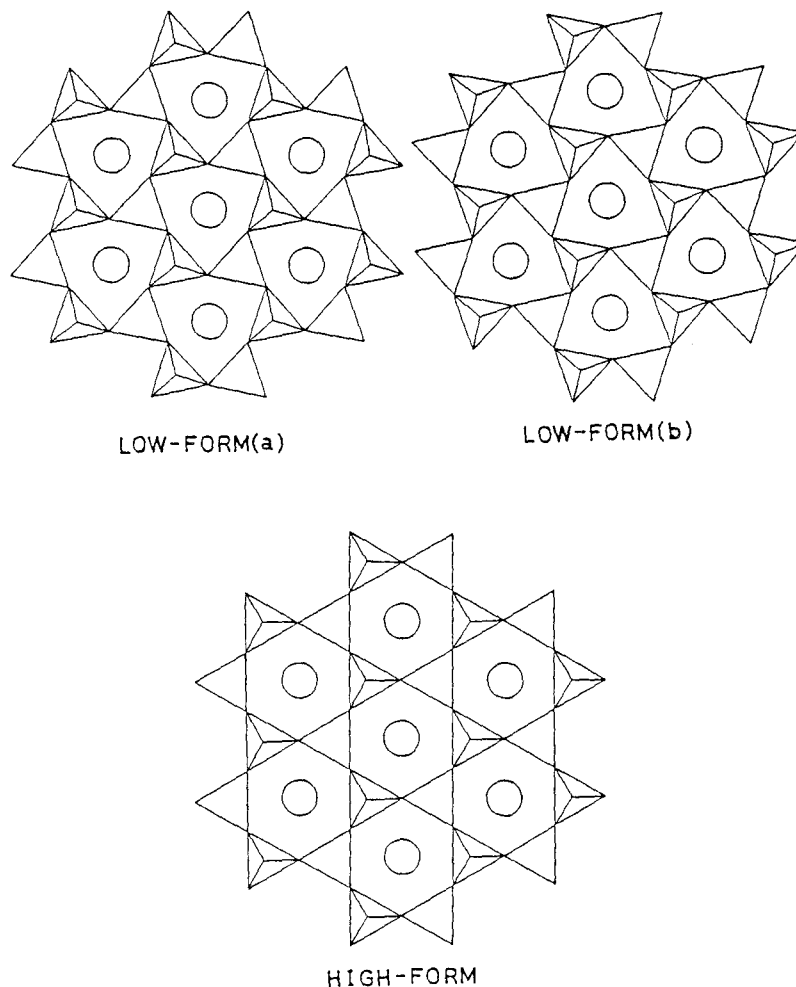

FIG. 4. Scheme of the crystal structure of high temperature form of kalsilite having $P6_3$ mc symmetries (lower), together with low temperature form of $P6_3$ (Upper, a and b). The forms a and b is mirror equivalent each other.

According to the interatomic distances of Si–O(2) (1.68 Å) and Al–O(2) (1.70 Å), which has the intermediate values of typical Si– and Al–O distances, it is probable that the domains are partly changed into disordered high kalsilite.

There are subgroup relationships among the types of kalsilite so far studied. Fig. 6 shows the subgroup relation of three types of kalsilite. As shown in the figure, $P6_3$ (low-kalsilite), $P6_3$ mc (high-kalsilite) and $P6_3/mmc$ (disordered high kalsilite) are in the relation of translation equivalent subgroups (International Tables for Crystallography, A, 1983). It is interesting to compare this fact with the classification of

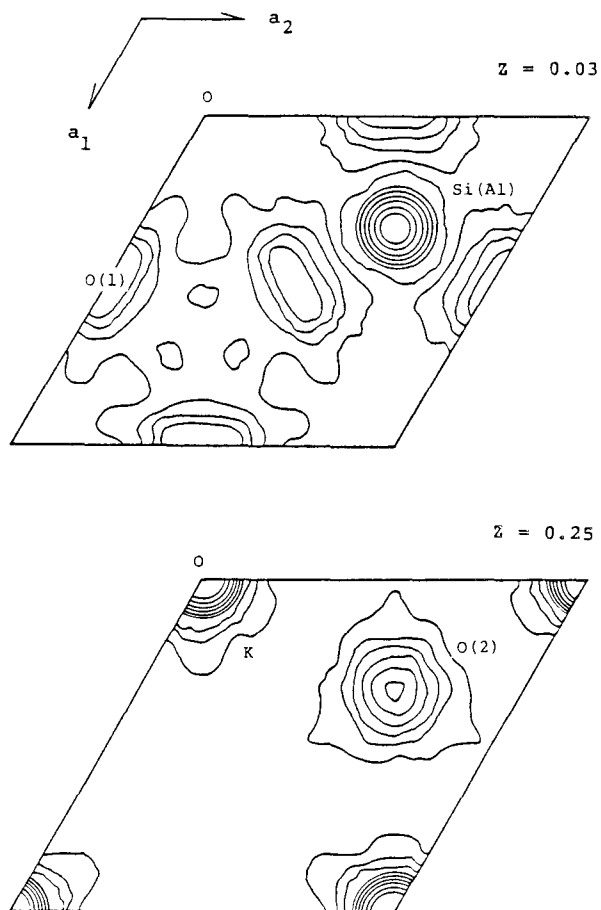

FIG. 5. Fourier section map (xy) of the high temperature form of kalsilite structure onto (001) plane. Upper, $z=0.03$. Lower, $z=0.25$. Contours are at intervals of $1.2 \text{ e.}\text{\AA}^{-3}$ starting from $0.5 \text{ e.}\text{\AA}^{-3}$.

framework silicates mentioned by Gottardi (1979), who divided kalsilite into three kinds of symmetries, namely topological symmetry ($P6_3/mmc$), topochemical symmetry ($P6_3mc$) and real symmetry ($P6_3$).

So far as the tectosilicates are concerned, it is probable that there is an intimate analogy between crystal structures simplified by the reduction of chemical components and those derived by the process of displacive phase transformations.

Conclusion

According to the investigations so far carried out, it is confirmed that kalsilite

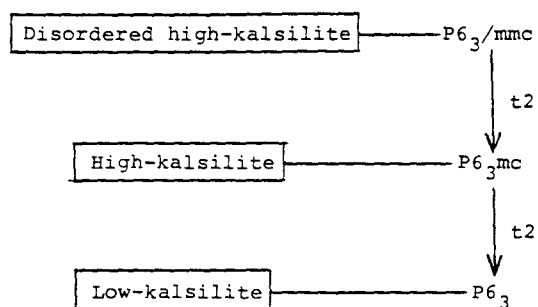

FIG. 6. Diagram showing the subgroup relationships among the three types of polymorphs. $P6_3/mmc$, $P6_3/mc$ and $P6_3$ kalsilite are in the relation of Zellengleichen subgroups.

undergoes displacive phase transformation at 865°C , and the structure of high temperature form of kalsilite, whose space group is $P6_3/mc$, is determined. There are also another phase transition point at about 650°C , which gives break points on the curves of lattice dimensions, a and c , versus temperature shown in Fig. 3.

Acknowledgement—Part of the cost expended by this investigation was defrayed by a research grant from the Ministry of Education, Science and Culture (No. 57540478).

References

- ABBOTT, R. N. (1984) *Amer. Miner.*, **69**, 449-457.
 ANDOU, Y. & KAWAHARA, A. (1982) *Miner. Journ.*, **11**, 2, 72-77.
 ANDOU, Y. & KAWAHARA, A. (1982) *Collected abstract, 30th anniversary meeting, Tsukuba*, 48.
 ANDOU, Y. & KAWAHARA, A. (1984) *Miner. Journ.*, **12**, 4, 153-161.
 BROWN, I. D. & WU, K. K. (1976) *Acta Cryst.*, **B32**, 1957-1959.
 DOLLASE, W. A. & FREEBORN, W. P. (1977) *Amer. Miner.*, **62**, 336-342.
 FOREMAN, N. & PEACOR, D. R. (1970) *Zeits. Krist.*, **132**, 45-70.
 GOTTARDI, G. (1979) *Tschermaks Miner. Petrogr. Mitt.*, **26**, 39-50.
 International Tables for Crystallography (1983) Vol. A, 32, 575 & 727. Dordrecht: Reidel Publishing Company.
 International Tables for X-ray Crystallography (1974) Vol. IV, 73-79. Birmingham: Kynoch Press.
 OKUNO, M., MARUMO, F. & OSSAKA, J. (1981) *Rept. Research Lab. Engin. Mater.*, Tokyo Inst. Technol., **6**, 35-46.
 PERROTA, A. J. & SMITH, J. V. (1965) *Miner. Mag.*, **35**, 588-595.
 SAKURAI, T. (1971) *The Universal Crystallographic Computation Program System*. The Crystallographic Society of Japan.

Received November 25, 1985; revised September 16, 1986.