

## THE WODGINITE GROUP. I. STRUCTURAL CRYSTALLOGRAPHY

T. SCOTT ERCIT

*Mineral Sciences Section, Canadian Museum of Nature, Ottawa, Ontario K1P 6P4*

FRANK C. HAWTHORNE AND PETR ČERNÝ

*Department of Geological Sciences, University of Manitoba, Winnipeg, Manitoba R3T 2N2*

### ABSTRACT

Four new crystal-structure refinements have been done on wodginite-group minerals. Two partially ordered samples were used in single-crystal experiments, one, tantalian, the other, ferroan. The ferroan sample was heated to induce order, and its structure was re-refined. In addition to the single-crystal experiments, a Rietveld refinement from powder-diffraction data was done on a fully ordered lithiowodginite. Refinements of the partially ordered samples show that they are structurally intermediate to wodginite and ixiolite, and that heating under conventional conditions of 1000°C for 16 hours induces full wodginite-type cation order. In terms of both individual and mean bond-lengths, data for Li-rich samples deviate significantly from established trends for Li-poorer samples in a manner consistent with disorder of Li off the central *A* position. Schemes of cation order for potential derivatives of ixiolite have been evaluated for cells up to four times the volume of the ixiolite cell  $\equiv$  size of the wodginite cell). For full  $ABC_2O_8$  cation order, four most-probable schemes of order result. Three of these involve a doubled cell; one involves a quadrupled cell, relative to an ixiolite parent. Only the scheme of order with a quadrupled cell occurs naturally, *i.e.*, the wodginite structure; there is nothing in its scheme of order to indicate why nature prefers it over the other three schemes; more sophisticated calculations of energy seem necessary.

*Keywords:* crystal-structure refinement, wodginite group, order-disorder, Rietveld method.

### SOMMAIRE

Nous avons effectué quatre nouveaux affinements de la structure cristalline de minéraux du groupe de la wodginite. Deux de ceux-ci, partiellement ordonnés, dont un est tantalière et l'autre, ferreux, ont été utilisés pour des expériences sur cristal unique. L'échantillon riche en fer a été chauffé pour promouvoir une mise en ordre, et l'affinement de sa structure a été répété. En plus, nous avons effectué l'affinement d'un échantillon de lithiowodginite complètement ordonné sur poudre par la méthode de Rietveld. Les affinements des échantillons partiellement ordonnés montrent qu'ils sont structurellement intermédiaires à la wodginite et à l'ixiolite, et qu'un chauffage sous conditions conventionnelles de 1000°C pour 16 heures mène à une mise en ordre complète des cations selon le modèle de la wodginite. D'après les longueurs des liaisons individuelles et moyennes, les données pour les échantillons riches en Li dévient de façon importante des tendances établies pour ceux qui sont plus pauvres en Li, et concordent avec l'hypothèse qu'il y a désordre du Li par rapport à la position centrale *A*. Nous avons évalué les schémas de mise en ordre des cations pour les dérivés potentiels de l'ixiolite pour des mailles jusqu'à quatre fois le volume de la maille de l'ixiolite, c'est-à-dire, de la maille de la wodginite. Pour le modèle d'une mise en ordre complète des cations selon  $ABC_2O_8$ , il en résulte quatre schémas plausibles. Trois de ceux-ci impliquent une maille doublée; un schéma requiert une maille quadruplée, par rapport à la maille de l'ixiolite. Seul le schéma de mise en ordre de la maille quadruplée se retrouve dans la nature, sous forme de wodginite. Rien n'explique le développement préférentiel de ce schéma, plutôt que les trois autres. Des calculs plus sophistiqués de l'énergie des structures semblent indiqués pour expliquer ce point.

(Traduit par la Rédaction)

*Mots-clés:* affinement de la structure cristalline, groupe de la wodginite, ordre-désordre, méthode de Rietveld.

### INTRODUCTION

The crystal structure of wodginite,  $MnSnTa_2O_8$ , was first recognized as a superstructure of ixiolite,  $(Ta,Sn,Mn)O_2$ , by Nickel *et al.* (1963) on the basis of X-ray powder-diffraction data. Elphick (1972)

proposed a model for the wodginite structure; however, only subcell reflections were used, resulting in an erroneous space-group for the structure. Grice (1973) attempted a full refinement of the structure (space group  $C2/c$ ). He showed that there are three cationic sites in the wodginite

structure, and that all cations are in octahedral coordination; the octahedra form  $\alpha$ - $\text{PbO}_2$ -like zig-zag chains *via* sharing of polyhedron edges. Graham & Thornber (1974) published a refinement of the wodginite structure in the space group  $Cc$ , which resulted in four cationic sites, two of which show incomplete order among cation occupants. Ferguson *et al.* (1976) re-investigated the structure of wodginite and showed that the results of Grice (1973) and Graham & Thornber (1974) are in error owing to incorrect choices of origin;  $C2/c$ , not  $Cc$ , is the correct space-group. Gatehouse *et al.* (1976) showed that the compound  $M\text{-LiTa}_3\text{O}_8$  is isostructural with wodginite, and obtained the same solution of the structure as Ferguson *et al.* (1976). A later Rietveld refinement of the  $M\text{-LiTa}_3\text{O}_8$  structure using neutron powder-diffraction data (Santoro *et al.* 1977) located the Li atom, which Gatehouse *et al.* (1976) could not find in their X-ray experiment.

Polyhedral representations of the wodginite structure are shown in Figures 1 and 2. Oxygen atoms form approximately hexagonally close-packed layers perpendicular to  $X$ . Cations occupy

one-half of the octahedral interstices at each level in the close-packed array of anions. There are three cationic sites, denoted here as  $A$ ,  $B$  and  $C$ . The  $A$  and  $B$  sites lie at the same level in the closest-packing, whereas the  $C$  sites lie at a different level; these layers alternate along  $X$ . All coordination polyhedra link *via* edge-sharing to form  $\alpha$ - $\text{PbO}_2$ -like zig-zag chains along  $Z$ . Chains are interconnected by corner-sharing linkages between levels of the closest-packed layering. The  $A$  and  $B$  polyhedra alternate along the zig-zag chains of their level; adjacent levels necessarily consist only of chains of  $C$  polyhedra.

Ideally, the  $A$  site contains Mn, the  $B$  site contains Sn, and the  $C$  site contains Ta, resulting in the ideal formula  $\text{MnSnTa}_2\text{O}_8$  ( $Z = 4$ ) for wodginite. Ferguson *et al.* (1976) showed that Ta can be disordered over the  $B$  and  $C$  sites; however, as disorder between the  $B$  and  $C$  sites does not modify the space-group symmetry, this behavior can only be easily detected by examining results of chemical analyses for Ta-overstuffed compositions. Powder-diffraction experiments show that some members of the wodginite group have X-ray-dif-

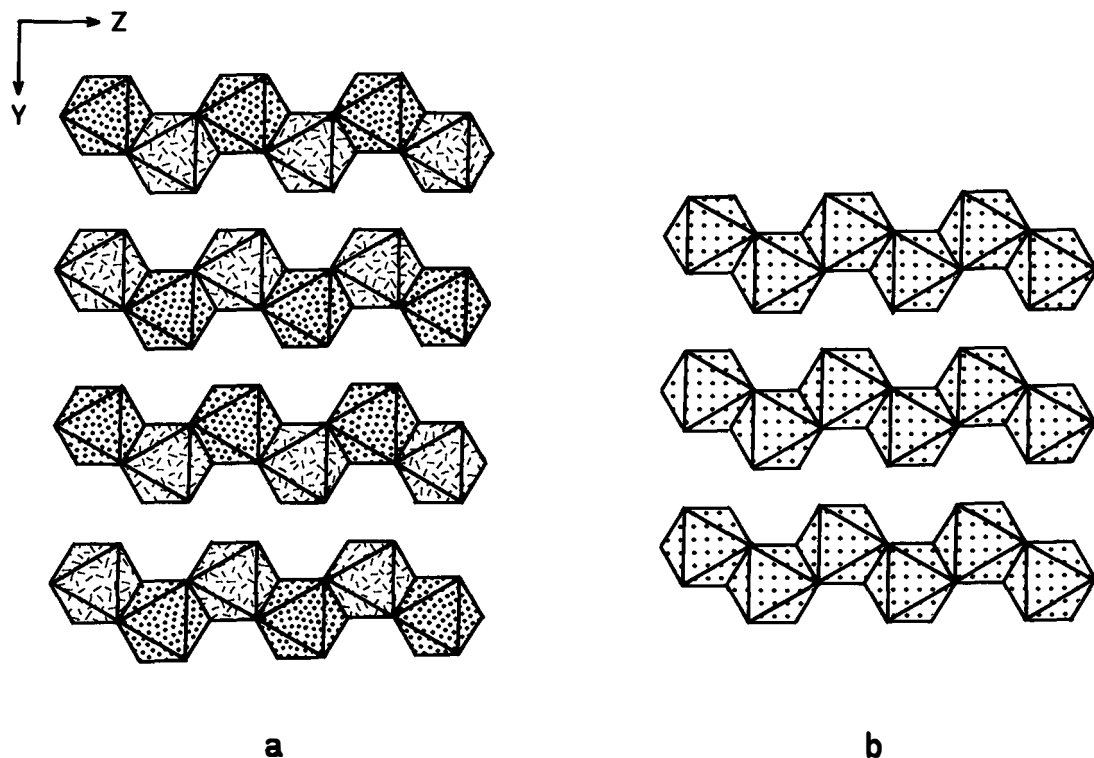

FIG. 1. The structure of ideal wodginite projected along  $X$ ; (a) the layer of  $A$ ,  $B$  octahedra; (b) the layer of  $C$  octahedra.  $A$  (Mn) octahedra are hatch-stippled,  $B$  (Sn) octahedra are densely stippled, and  $C$  (Ta) octahedra are lightly stippled.

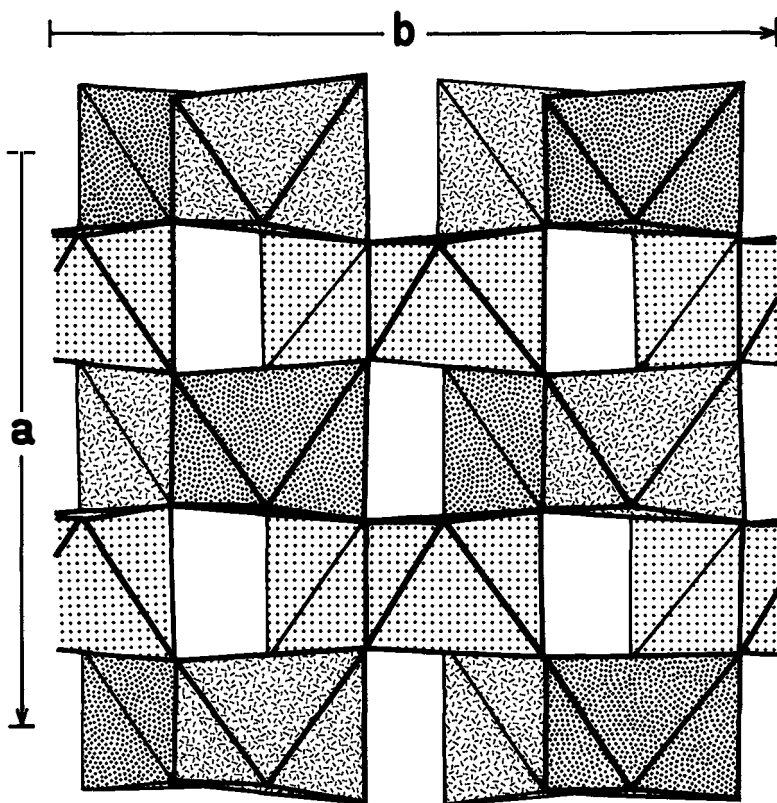

FIG. 2. The wodginite structure projected along  $Z$ ; the zig-zag chains of the structure are perpendicular to the plane of the page. Shading is as in Figure 1.

fraction properties intermediate to those of wodginite and ixiolite (as proposed by Lahti 1982) or wodginite and wolframite [as proposed by Maksimova & Khvostova (1970) and Polyakov & Cherepivskaya (1981)]. The model involving ixiolite implies disorder over all cationic sites; the model involving wolframite implies disorder only over the  $A$  and  $B$  sites. In principle, it should be relatively easy to differentiate between the two models on the basis of site occupancies derived from crystal-structure refinements. To avoid any confusion regarding order-disorder phenomena in wodginite-group minerals, we shall use the following nomenclature. For samples with diffraction properties fully compatible with the wodginite structure, we use the term (*fully*) *ordered*; for samples with diffraction properties intermediate to those of the wodginite structure and those of some substructure (e.g., ixiolite, wolframite), we use the term *partially ordered*. Disorder of Ta over the  $B$  and  $C$  sites is here referred to as *Ta disorder*; it is fully compatible

with the wodginite structure, and does not contradict the terminology described above.

In companion papers (Ericit *et al.* 1992a,b), we outline variations in the chemistry and structure of what we now recognize to be the *wodginite group*. The goal of the present paper is to investigate the structural properties of wodginite-group minerals, with emphasis on order-disorder relationships.

## EXPERIMENTAL

### *Single-crystal diffraction*

Two samples of wodginite-group minerals were examined by single-crystal X-ray diffraction; both are partially ordered, one intermediate in composition between wodginite and lithiowodginite (sample CX-1: Coosa Co., Alabama), the other intermediate in composition between wodginite and ferrowodginite (sample A-17: Ankole, Uganda). Sample CX-1 was donated by E.E. Foord (U.S. Geological Survey), and was described as having

diffraction properties intermediate between those of wodginite and wolframite (E.E. Foord, pers. comm.). Sample A-17 was investigated in Ercit *et al.* (1992a); it shows diffraction properties intermediate between those of wodginite and ixiolite. The observed morphology indicates that both crystals are sector-twinned, with *Y* as the twin axis. In both cases, a fragment from one sector was isolated and examined by the precession method to confirm the absence of twinning within each fragment. To minimize differential absorption, the crystals were hand-shaped to approximate spheres prior to data collection. Following initial collection of intensity data, the crystal of sample A-17 was heated in an attempt to induce cation order, and data were recollected on this crystal. Conditions of the heating experiment were as follows: 1000°C for 16 hours in an argon atmosphere, in a Ag-Pd foil basket, using a vertical quench furnace.

Intensity data were collected on the single crystals with a Nicolet R3m four-circle diffractometer, using the experimental method of Ercit *et al.* (1986). Fifteen to twenty-five intense reflections (to  $2\theta = 30^\circ$ ) were used in centering each crystal; least-squares refinement of the setting angles gave the unit-cell parameters in Table 1, and the orientation matrix used for data collection. In each case, one asymmetric unit of data was collected to a maximum  $\sin\theta/\lambda$  of 0.7035 to give the numbers of unique reflections shown in Table 1. The data were empirically corrected for absorption (using  $\psi$ -scan data),  $L_p$  and background effects using the SHELXTL package of programs. A reflection was considered observed if its intensity exceeded that of three times its standard deviation; application of this criterion resulted in the numbers of observed reflections given in Table 1. After collection of the intensity data, the crystals used in each collection were mounted in epoxy and polished for electron-microprobe analysis. The conditions of electron-microprobe analysis and the method of calculation of the formula are described in Ercit *et al.* (1992a);

TABLE 1. MISCELLANEOUS INFORMATION FOR SINGLE-CRYSTAL STRUCTURE REFINEMENTS

	Partially ordered Wodginite (CX-1)	Ferroan Wodginite (A-17)	Ferroan Wodginite (heated) (A-17h)
<i>a</i> (Å)	9.500(5)	9.450(1)	9.450(2)
<i>b</i>	11.465(6)	11.421(2)	11.442(2)
<i>c</i>	5.139(3)	5.119(1)	5.083(1)
$\beta$	90.51(4)	90.40(1)	90.75(2)
<i>V</i> (Å <sup>3</sup> )	559.1(6)	553.0(1)	549.5(2)
Space Group	C2/c	C2/c	C2/c
Mean radius (mm)	0.08	0.09	0.09
$\mu$ (MoK $\alpha$ , cm <sup>-1</sup> )	414	402	402
Total $F_o$ , obs. $F_o$	862, 651	815, 729	810, 792
Final <i>R</i> , <i>wR</i> (%)	6.0, 5.8	6.5, 6.4	8.5, 6.9

$R = \sum (|F_o| - |F_c|) / \sum |F_o|$   
 $wR = [\sum w(|F_o| - |F_c|)^2 / \sum w|F_o|^2]^{1/2}$ ,  $w = 1$

TABLE 2. CHEMICAL COMPOSITIONS OF WODGINITE-GROUP MINERALS USED IN STRUCTURE REFINEMENTS

	Wodginite (G69-17)	Partially Ordered Wodginite (CX-1)	Lithio- wodginite (TSE-76)	Ferroan Wodginite (A-17)
Li <sub>2</sub> O (wt%)	0.0	0.22	1.21	0.03
MnO	10.7	7.7	4.6	6.1
FeO	0.0	2.3	0.0	4.7
SnO	—	0.7	—	—
Fe <sub>2</sub> O <sub>3</sub>	0.8	2.6	0.1	1.8
TiO <sub>2</sub>	1.4	—	—	2.5
ZrO <sub>2</sub>	—	1.5	—	—
SnO <sub>2</sub>	13.0	10.3	4.6	10.7
Nb <sub>2</sub> O <sub>5</sub>	4.0	7.5	5.2	6.2
Ta <sub>2</sub> O <sub>5</sub>	68.6	69.1	83.4	65.5
	98.6	102.0	99.3	99.5
Cations per 32(O)				
Li	0.00	0.36	2.13	0.05
Mn	3.95	2.70	1.73	2.15
Fe <sup>2+</sup>	0.00	0.81	0.00	1.64
Sn <sup>2+</sup>	—	0.13	—	—
Fe <sup>3+</sup>	0.26	0.82	0.05	0.55
Ti	0.47	—	—	0.76
Zr	—	0.30	—	—
Sn <sup>4+</sup>	2.25	1.70	0.81	1.77
Nb	0.78	1.40	1.04	1.54
Ta	8.11	7.78	9.97	7.38
	15.82	16	15.72	15.84

G69-17: Formula recalculated from analysis from Ferguson *et al.* (1976); Li<sub>2</sub>O and Fe<sup>2+</sup>:Fe<sup>3+</sup> calculated by WODGINITE program.  
CX-1: Electron microprobe analysis of crystal used in structure analysis; Li<sub>2</sub>O and Fe<sup>2+</sup>:Fe<sup>3+</sup> calculated by WODGINITE program; Sn<sup>2+</sup>:Sn<sup>4+</sup> by <sup>119</sup>Sn-Mössbauer (pers. comm. E.E. Foord).  
TSE-76: Electron microprobe analysis; Li<sub>2</sub>O by atomic absorption spectroscopy; Fe<sup>2+</sup>:Fe<sup>3+</sup> calculated by WODGINITE program.  
A-17: Electron microprobe analysis of crystal used in structure analysis; Li<sub>2</sub>O by atomic absorption spectroscopy; Fe<sup>2+</sup>:Fe<sup>3+</sup> calculated by WODGINITE program.

the resulting compositions and unit formulae are given in Table 2.

### Powder diffraction

One wodginite-group mineral from the Tanco pegmatite (sample TSE-76) was found to have a high proportion of Ta at the *B* site according to its chemical composition, and was suspected of having a large proportion of vacancies at the *A* site. On the basis of these properties, we considered a structure refinement of this sample to be important; however, the material was so finely crystalline and in such intricate patterns of parallel growth that single-crystal methods of investigation were impossible. Consequently, we decided to attempt a structure refinement using X-ray powder-diffraction data (Rietveld method).

The diffraction data were collected with a Philips PW1710 automated powder diffractometer using graphite-monochromated CuK $\alpha$  radiation and a 1° divergence slit. The sample was ground for 15 minutes in acetone prior to mounting in a sample holder. The data were collected in a step-scanning mode from 10° to 90°  $2\theta$ . A step size of 0.08°  $2\theta$  and a counting time of 5 s per step were selected so as to obtain accurate estimated standard deviations from count statistics (Hill & Madsen 1984). The average result of two electron-

microprobe analyses for sample TSE-76 is given in Table 2; the conditions of analysis are given in Ercit *et al.* (1992a).

## REFINEMENT

### Single-crystal-diffraction data

Miscellaneous information about the refinement of the single-crystal X-ray-diffraction data are given in Table 1. The structures were refined using SHELX76 (Sheldrick 1976) in the CRYSRULER package of programs (Rizzoli *et al.* 1986). Scattering factors for neutral atoms, together with anomalous dispersion corrections, were taken from Cromer & Mann (1968) and Cromer & Liberman (1970), respectively. Observed and calculated structure-factors for each structure are available from the Depository of Unpublished Data, CISTI, National Research Council of Canada, Ottawa, Ontario K1A 0S2.

Structure refinement for sample CX-1 involved a starting model with a wodginite-like pattern of order. Starting positions were taken from Ferguson *et al.* (1976), and site contents for the various cationic constituents of this hypothetical fully ordered model were assigned by applying the conclusions of Ferguson *et al.* (1976) and Ercit *et al.* (1992a) to the results of the electron-microprobe analysis (Table 2). In the first stage of refinement, it was assumed that the style of cation disorder followed a wolframite-like model. For fully ordered wodginite, the structural formula is  $ABC_2O_8$ ; for the disordered wolframite model, the structural formula is  $(AB)_{\Sigma 2}C_2O_8$ ; through the use of constraint equations involving site occupancies, the proportion of each component could be refined as a single variable. Refinement of this wodginite-wolframite model resulted in the following  $R$  factors:  $R = 8.0$ ,  $wR = 7.6\%$ . Several unsuitable features were noted in this model. Difference-Fourier maps were found to indicate that the  $A$  and  $B$  sites were scattering more strongly, and the  $C$  site less strongly, than the model could accommodate, indicative of disorder between the stronger scatterers of the  $C$  site (*i.e.*, Ta) and the weaker scatterers of the  $A$  and  $B$  sites (*i.e.*, Mn, Sn). Consequently, a second refinement was carried out, this time with the assumption that the style of cation disorder followed an ixiolite-like model, with a structural formula  $(ABC)_{\Sigma 4}O_8$ . Again, through the use of constraint equations involving site occupancies, the proportion of wodginite *versus* ixiolite character was refined as a single variable. Refinement converged at values of  $R = 6.0$ ,  $wR = 5.8\%$ , a significant improvement over the earlier refinement. The success of this model was further shown by difference-Fourier maps: electron dif-

ferences at the cation sites were one half those of the first model. The degree of order based on this ixiolite-wodginite mixing model is 59(1)%. The maximum peak-height on the final difference-Fourier map was  $1.8 e^-/\text{\AA}^3$  which, given the complex chemistry, high coefficient of linear absorption and somewhat irregular shape of the crystal, seems reasonable.

On the basis of the refinement of sample CX-1, and from precession photographs, the order-disorder mixing model for sample A-17 was assumed to be of the wodginite-ixiolite type. Using the same techniques as for sample CX-1, refinement of the data set for the unheated crystal converged at values of  $R = 6.5$ ,  $wR = 6.4\%$ , and gave a degree of order of 66(1)%. The refinement of the data set for the heated crystal converged at values of  $R = 6.5$ ,  $wR = 6.9\%$ , and gave a degree of order of 97(2)%, indicating that the heating experiment induced full order among cations (in terms of a wodginite-like pattern of order *versus* an ixiolite-like pattern of order). For both data collections, the maximum peak-height on the final difference-Fourier map was  $3 e^-/\text{\AA}^3$ . We attribute this to errors in the absorption correction, due to the high value of  $m\cdot\mu$  (Table 1), in conjunction with problems with approximations of the crystal shape (hand-shaped).

### Rietveld refinement

The refinement of the powder X-ray-diffraction data was done with the program LHPM (Hill & Howard 1986), a modification of the program DBW 3.2 (Wiles & Young 1981). Scattering curves for neutral atoms were used. A pseudo-Voigt function with a  $2\theta$ -dependent, refinable Lorentzian:Gaussian character was used as the profile function.

The refinement was done in three stages. First the scale factor, unit-cell parameters, mean background and  $0^\circ 2\theta$  position were refined, with all positional parameters fixed at values for ordered wodginite (Ferguson *et al.* 1976). Temperature factors were initially fixed at  $B(\text{cation sites}) = 0.6 \text{\AA}^2$ ,  $B(\text{anion sites}) = 0.8 \text{\AA}^2$ , but for later stages of refinement were fixed at values given by Ferguson *et al.* (1976) for cations (anisotropic) and anions (isotropic; set at average of  $B = 1.0 \text{\AA}^2$ ). For the second stage of refinement, the peak shape, asymmetry and half-width parameters, and coefficients of the background polynomial (4th order) were included as variables. For this and subsequent stages of the refinement, the refined  $2\theta$  range for each peak was set at four times the full width of the peak at half-height. For the final stage of the refinement, all positional parameters and the occupancy of the  $A$  site were added to the list of

TABLE 3. FINAL PARAMETERS FOR RIETVELD STRUCTURE REFINEMENT OF LITHIOWODGINITE TSE-76

Scan range ( $2\theta$ , CuK $\alpha$ ):	10 to 90,	step 0.08	
Unit cell parameters:	a 9.4538(6), $\beta$ 91.045(3),	b 11.4977(6), V 551.81(5)	c 5.0775(2)
Peak shape parameters:	$\gamma$ 0.7(1),	$\gamma_2$ 0.010(6),	$\gamma_3$ -0.00010(6)
Asymmetry parameter:	AS 0.55(6)		
Half-width parameters:	U 0.08(3),	V -0.04(2),	W 0.027(4)
Preferred orientation parameters:	P1 -2.7(4),	P2 0.74(1)	
Durbin-Watson d-statistic:	1.25		
Discrepancy indices (%):	$R_p$ 5.6	$R_{wp}$ 7.3	$R_B$ 3.8
	$R_{exp}$ 2.6		
<b>Expressions used</b>			
Peak shape:	$\gamma = \gamma_1 + \gamma_2 2\theta + \gamma_3 (2\theta)^2$		
Asymmetry:	$A_{ik} = 1 - AS [\text{sign}(2\theta - 2\theta_0)] [(2\theta - 2\theta_0)^2 \cot \theta_k]$		
Half-widths:	$H_k = (U \tan^2 \theta + V \tan \theta + W) / 2$		
Preferred orientation:	$I_{calc} = I_{calc} [P_1 + (1 - P_2) \exp(-P_1 \cos^2 \theta)]$		
Discrepancy indices:	$R_p = \sum  y_{io} - y_{ic}  / \sum y_{io}$		
	$R_{wp} = [\sum w_i (y_{io} - y_{ic})^2 / \sum w_i y_{io}^2]^{1/2}$ where $w_i = 1 / y_{io}$		
	$R_B = \sum  I_{obs} - I_{calc}  / \sum I_{obs}$		
	$R_{exp} = [(N-P) / \sum w_i y_{io}^2]^{1/2}$ where $w_i = 1 / y_{io}$		

variables, resulting in  $R_p = 6.5$ ,  $R_{wp} = 8.2$ ,  $R_B = 5.4\%$ . At this point, the  $I(\text{obs})-I(\text{calc})$  difference pattern showed that the intensities of a number of reflections were underestimated by the model, in a manner consistent with either minor admixture of manganotantalite in the sample, or with a slight preferred orientation of the powder. A two-phase refinement involving a lithiowodginitite and manganotantalite admixture resulted in insignificantly different  $R$  factors; consequently, contamination by manganotantalite is judged to be unlikely. The  $I(\text{obs})-I(\text{calc})$  difference pattern suggested that the  $\{110\}$  cleavage is responsible for the proposed preferred orientation; refinement of the correction for preferred orientation resulted in significantly improved  $R$  factors of  $R_p = 5.6$ ,  $R_{wp} = 7.3$ ,  $R_B = 3.8\%$ . The occupancy of the  $A$  site converged at 0.85(2), which agrees reasonably well with the results of the chemical analysis (occupancy of 0.96), considering the inhomogeneity of the bulk sample (Ercit *et al.* 1992a). The final values of important profile-parameters are given in Table 3. A list of observed and calculated profile-intensities and of observed and calculated intensities of reflections are available from the Depository of Unpublished Data, CISTI.

## RESULTS

The final values of the positional parameters and equivalent isotropic displacement-factors for the four structure refinements of the present study, for wodginitite G69-17 (Ferguson *et al.* 1976) and for the compound  $M\text{-LiTa}_3\text{O}_8$  (Gatehouse *et al.* 1976, Santoro *et al.* 1977) are given in Table 4. For this and other tables, data for the  $A$  site in  $M\text{-LiTa}_3\text{O}_8$  are taken from the powder neutron-diffraction work of Santoro *et al.* (1977); data for all other

TABLE 4. POSITIONAL PARAMETERS AND DEGREES OF CATION ORDER FOR WODGINITE-GROUP MINERALS

Site	Wodginitite *	Partially Ordered Wodginitite (CX-1)	$M\text{-LiTa}_3\text{O}_8$ **	Lithiowodginitite (TSE-76)	Ferroan Wodginitite (A-17)	Ferroan Wodginitite (Heated) (A-17h)
A	x 0 y 0.6575(4) z 1/4	0 0.6637(3) 1/4	0 0.655(2) 1/4	0 0.662(3) 1/4	0 0.6634(3) 1/4	0 0.6601(4) 1/4
B	x 0 y 0.1689(2) z 1/4	0 0.1681(2) 1/4	0 0.1701(1) 1/4	0 0.1699(5) 1/4	0 0.1680(2) 1/4	0 0.1687(2) 1/4
C	x 0.2498(1) y 0.4131(1) z 0.2472(2)	0.2493(1) 0.4146(1) 0.2497(3)	0.2415(1) 0.4138(1) 0.2466(2)	0.2451(5) 0.4122(3) 0.246(1)	0.2488(1) 0.4143(1) 0.2493(2)	0.2468(1) 0.4133(1) 0.2480(2)
O1	x 0.133(2) y 0.056(2) z 0.083(4)	0.137(2) 0.056(2) 0.075(4)	0.133(2) 0.063(2) 0.079(4)	0.147(3) 0.092(3) 0.080(8)	0.133(2) 0.056(2) 0.082(3)	0.135(2) 0.058(1) 0.080(4)
O2	x 0.145(2) y 0.450(2) z 0.580(4)	0.140(2) 0.444(2) 0.574(3)	0.146(2) 0.452(2) 0.559(4)	0.131(4) 0.456(3) 0.543(8)	0.143(2) 0.446(1) 0.571(3)	0.146(2) 0.449(1) 0.583(3)
O3	x 0.122(2) y 0.306(2) z 0.098(4)	0.116(2) 0.304(1) 0.097(3)	0.119(2) 0.303(2) 0.107(4)	0.116(3) 0.322(4) 0.074(6)	0.120(2) 0.305(1) 0.098(3)	0.121(2) 0.304(1) 0.105(3)
O4	x 0.116(2) y 0.183(2) z 0.576(4)	0.114(2) 0.186(2) 0.585(3)	0.115(2) 0.179(2) 0.573(4)	0.119(3) 0.180(4) 0.584(8)	0.115(2) 0.185(1) 0.583(3)	0.114(2) 0.184(1) 0.584(3)

\* Ferguson *et al.* (1976)\*\* Gatehouse *et al.* (1976); Li position from Santoro *et al.* (1977)

TABLE 5. ANISOTROPIC DISPLACEMENT-PARAMETERS FOR WODGINITE-GROUP MINERALS (PRESENT STUDY)

Site	Partially Ordered Wodginitite (CX-1)	Ferroan Wodginitite (A-17)	Ferroan Wodginitite (Heated) (A-17h)
A	$U_{11}$ 247(14) $U_{22}$ 219(15) $U_{33}$ 261(14) $U_{12}$ 0 $U_{13}$ 36(10) $U_{23}$ 0	179(14) 202(15) 197(14) 0 4(10) 0	176(22) 193(23) 247(25) 0 10(16) 0
B	$U_{11}$ 240(8) $U_{22}$ 232(8) $U_{33}$ 220(8) $U_{12}$ 0 $U_{13}$ 41(6) $U_{23}$ 0	157(8) 181(6) 172(6) 0 8(6) 0	114(6) 112(6) 187(9) 0 12(6) 0
C	$U_{11}$ 240(5) $U_{22}$ 228(5) $U_{33}$ 195(4) $U_{12}$ -7(4) $U_{13}$ 40(3) $U_{23}$ 1(4)	162(5) 200(5) 201(5) -5(3) 2(3) 0(4)	181(4) 181(5) 239(5) -5(3) 2(3) 1(4)
O1	$U_{11}$ 542(123) $U_{22}$ 295(84) $U_{33}$ 360(103) $U_{12}$ -11(83) $U_{13}$ 274(87) $U_{23}$ -50(61)	293(82) 250(74) 287(85) -29(63) 31(65) 53(82)	263(82) 189(71) 394(99) -19(62) 76(71) 17(68)
O2	$U_{11}$ 350(93) $U_{22}$ 282(78) $U_{33}$ 260(84) $U_{12}$ 79(67) $U_{13}$ -83(66) $U_{23}$ -124(66)	271(77) 249(73) 225(76) 31(60) -66(59) -29(57)	233(76) 199(71) 280(83) 25(56) 2(63) -13(62)
O3	$U_{11}$ 241(70) $U_{22}$ 225(78) $U_{33}$ 285(74) $U_{12}$ 104(57) $U_{13}$ -20(55) $U_{23}$ -33(59)	285(76) 169(70) 273(75) 22(56) -28(60) -24(57)	241(73) 148(65) 278(78) -13(56) 30(60) -11(59)
O4	$U_{11}$ 297(77) $U_{22}$ 337(90) $U_{33}$ 381(84) $U_{12}$ 267(73) $U_{13}$ 25(65) $U_{23}$ -79(62)	220(68) 254(78) 301(76) 47(59) 0(57) -4(62)	239(73) 222(74) 262(76) 39(61) 38(60) -39(63)

Note: all  $U_{ij}$  are  $\text{Å}^2 \times 10^4$ ; expression used:  $\exp[-2\pi^2(U_{11}h^2a^2 + \dots + 2U_{12}hka^2b^2 + \dots)]$

sites are taken from the single-crystal X-ray-diffraction results of Gatehouse *et al.* (1976).

Anisotropic displacement-factors for the single-crystal refinements of the present study are given in Table 5. The partially ordered samples show large displacement-factors compared to previous refinements of ordered members of the wodginite group (Ferguson *et al.* 1976, Gatehouse *et al.* 1976). However, the displacement-factors for heated *versus* unheated sample A-17 are not significantly different, indicating either that (1) if the large displacement-factors represent minor positional displacements between the various constituents of a given site averaged over the volume of the crystal, then heating does not significantly minimize these positional displacements, or (2) the large displacement-factors for the single crystals of the present study are indicative of an error introduced by inadequate absorption-correction; both crystals studied are larger than ideal on the basis of their linear absorption-coefficients. It is presently not possible to state which of these effects is dominant.

The degree of order for each sample, based on a wodginite-ixiolite mixing model, is summarized in Table 6. Owing to the application of constraint equations, the degree of order for partially ordered

samples is determined with a high degree of precision. However, the mixing model used is continuous and linear; if the order-disorder transformation from wodginite to ixiolite is non-linear or discontinuous, then the standard deviations associated with the refined degrees of order would represent minimum estimates. Actual assignments of sites based on the application of estimates of degree of order are given in Table 6, and were used in all subsequent calculations involving site chemistry (*e.g.*, bond valences).

TABLE 7. BOND LENGTHS (Å) FOR WODGINITE-GROUP MINERALS

	Wodginite (G69-17)	Partially Ordered Wodginite (CX-1)	M-LiTa <sub>3</sub> O <sub>6</sub> **	Lithio- wodginite (TSE-76)	Ferroan Wodginite (A-17)	Ferroan Wodginite (Heated) (A-17H)
<b>A - O<sub>2a,g</sub> ∑</b>	2.10(2)	2.04(2)	2.09(2)	2.13(4)	2.06(2)	2.10(2)
O <sub>3h,i</sub> ∑	2.14(2)	2.12(2)	2.18(2)	2.17(3)	2.14(2)	2.18(2)
O <sub>4a,g</sub> ∑	2.31(2)	2.21(2)	2.39(3)	2.30(5)	2.22(2)	2.25(2)
<A-O>	2.19	2.12	2.21	2.13	2.14	2.17
<b>B - O<sub>1ab</sub> ∑</b>	2.00(2)	2.04(2)	1.97(2)	2.04(4)	1.99(2)	2.00(2)
O <sub>3a,b</sub> ∑	2.10(2)	2.07(2)	2.04(2)	2.06(4)	2.09(2)	2.07(2)
O <sub>4a,b</sub> ∑	1.98(2)	2.03(2)	1.85(2)	2.02(3)	2.02(2)	2.01(2)
<B-O>	2.03	2.05	1.99	2.11	2.04	2.03
<b>C - O<sub>1c</sub></b>	2.06(2)	2.02(2)	2.06(2)	2.04(4)	2.06(2)	2.09(2)
O <sub>1d</sub>	2.18(2)	2.14(2)	2.25(2)	2.18(3)	2.15(2)	2.17(2)
O <sub>2a</sub>	1.94(2)	2.00(2)	1.89(2)	1.92(4)	1.97(2)	1.93(2)
O <sub>2b</sub>	2.07(2)	2.12(2)	2.02(2)	2.12(4)	2.09(2)	2.07(2)
O <sub>3a</sub>	1.86(2)	1.95(2)	1.85(2)	1.82(4)	1.91(2)	1.88(2)
O <sub>4f</sub>	1.82(2)	1.93(2)	1.83(2)	1.87(4)	1.92(2)	1.90(2)
<C-O>	2.00	2.03	2.00	1.99	2.01	2.00

\* Ferguson *et al.* (1976)

\*\* calculated from Gatehouse *et al.* (1976) and Santoro *et al.* (1977)

TABLE 8. BOND ANGLES (°) FOR WODGINITE-GROUP MINERALS

	Wodginite (G69-17)	Partially Ordered Wodginite (CX-1)	M-LiTa <sub>3</sub> O <sub>6</sub> **	Lithio- wodginite (TSE-76)	Ferroan Wodginite (A-17)	Ferroan Wodginite (Heated) (A-17H)
<b>A Octahedron</b>						
O <sub>2a</sub> - O <sub>2g</sub>	108(1)	104(1)	108(2)	101(2)	105(1)	107(1)
O <sub>2a,g</sub> - O <sub>3h,i</sub>	99(1)	98(1)	101(1)	99(2)	97(1)	99(1)
O <sub>2a,g</sub> - O <sub>3h</sub>	95(1)	94(1)	95(1)	88(1)	94(1)	94(1)
O <sub>2a,g</sub> - O <sub>4h</sub>	88(1)	89(1)	89(1)	92(2)	89(1)	89(1)
O <sub>3h,i</sub> - O <sub>4a,g</sub>	85(1)	87(1)	84(1)	88(2)	86(1)	85(1)
O <sub>3h,i</sub> - O <sub>4a,g</sub>	77(1)	78(1)	75(1)	83(2)	79(1)	78(1)
O <sub>4a</sub> - O <sub>4g</sub>	78(1)	78(1)	73(1)	78(2)	77(1)	75(1)
<O-A-O>	90	90	90	90	90	90
<b>B Octahedron</b>						
O <sub>1a</sub> - O <sub>1b</sub>	101(1)	103(1)	102(1)	105(2)	100(1)	102(1)
O <sub>1a,b</sub> - O <sub>3a,b</sub>	94(1)	88(1)	88(1)	89(1)	88(1)	88(1)
O <sub>1a,b</sub> - O <sub>4a,b</sub>	92(1)	88(1)	93(1)	90(1)	95(1)	95(1)
O <sub>1a,b</sub> - O <sub>4b,a</sub>	88(1)	92(1)	91(1)	94(1)	92(1)	92(1)
O <sub>3a</sub> - O <sub>3b</sub>	84(1)	81(1)	82(1)	78(1)	83(1)	83(1)
O <sub>3a,b</sub> - O <sub>4a,b</sub>	87(1)	88(1)	86(1)	91(1)	87(1)	87(1)
O <sub>3a,b</sub> - O <sub>4b,a</sub>	88(1)	83(1)	88(1)	84(1)	84(1)	88(1)
<O-B-O>	90	90	90	90	90	90
<b>C Octahedron</b>						
O <sub>1c</sub> - O <sub>1d</sub>	88(1)	88(1)	85(1)	88(1)	86(1)	88(1)
O <sub>1c</sub> - O <sub>2a</sub>	76(1)	77(1)	78(1)	75(1)	77(1)	78(1)
O <sub>1c</sub> - O <sub>3a</sub>	87(1)	87(1)	86(1)	91(1)	87(1)	88(1)
O <sub>1c</sub> - O <sub>4f</sub>	87(1)	86(1)	84(1)	87(1)	86(1)	85(1)
O <sub>1d</sub> - O <sub>2a</sub>	77(1)	78(1)	77(1)	78(1)	78(1)	78(1)
O <sub>1d</sub> - O <sub>2b</sub>	81(1)	81(1)	80(1)	81(1)	81(1)	81(1)
O <sub>1d</sub> - O <sub>4f</sub>	85(1)	87(1)	83(1)	87(1)	85(1)	86(1)
O <sub>2a</sub> - O <sub>2b</sub>	88(1)	88(1)	90(1)	85(1)	89(1)	89(1)
O <sub>2a</sub> - O <sub>3a</sub>	98(1)	98(1)	95(1)	98(2)	98(1)	98(1)
O <sub>2a</sub> - O <sub>4f</sub>	95(1)	95(1)	94(1)	101(1)	95(1)	98(1)
O <sub>2b</sub> - O <sub>3a</sub>	90(1)	90(1)	100(1)	81(2)	91(1)	92(1)
O <sub>2b</sub> - O <sub>4f</sub>	104(1)	103(1)	103(1)	111(1)	103(1)	103(1)
<O-C-O>	90	90	90	90	90	90

\* Ferguson *et al.* (1976)

\*\* calculated from Gatehouse *et al.* (1976) and Santoro *et al.* (1977)

TABLE 6. SITE CONTENTS FOR WODGINITE-GROUP MINERALS

	Wodginite (G69-17)	Partially Ordered Wodginite (CX-1)	M-LiTa <sub>3</sub> O <sub>6</sub>	Lithio- wodginite (TSE-76)	Ferroan Wodginite (A-17)	Ferroan Wodginite (Heated) (A-17H)
<b>A Site</b>						
Li	0.00	0.25	4.00	2.13	0.04	0.05
Mn	3.95	1.88	---	1.73	1.80	2.09
Fe <sup>2+</sup>	---	0.56	---	0.00	1.22	1.60
Sr <sup>2+</sup>	---	0.09	---	---	---	---
Fe <sup>3+</sup>	0.00	0.08	---	0.00	0.05	0.00
Ti	0.00	---	---	---	0.08	0.01
Zr	---	0.03	---	---	---	---
Sr <sup>4+</sup>	0.00	0.18	---	0.00	0.15	0.02
Nb	0.00	0.14	---	0.00	0.13	0.01
Ta	0.00	0.81	---	0.00	0.83	0.68
	3.95	4.00	4.00	3.86	3.86	3.84
<b>B Site</b>						
Li	0.00	0.04	---	0.00	0.00	0.00
Mn	0.00	0.28	---	0.00	0.18	0.02
Fe <sup>2+</sup>	---	0.08	---	0.00	0.14	0.01
Sr <sup>2+</sup>	---	0.02	---	---	---	---
Fe <sup>3+</sup>	0.26	0.56	---	0.05	0.41	0.53
Ti	0.47	---	---	---	0.57	0.75
Zr	---	0.21	---	---	---	---
Sr <sup>4+</sup>	2.25	1.17	---	0.81	1.32	1.73
Nb	0.00	0.14	---	0.00	0.13	0.01
Ta	0.89	1.50	4.00	3.01	1.23	0.95
	3.87	4.00	4.00	3.86	3.98	4.00
<b>C Site</b>						
Li	0.00	0.08	---	0.00	0.01	0.00
Mn	0.00	0.58	---	0.00	0.38	0.04
Fe <sup>2+</sup>	---	0.17	---	0.00	0.28	0.03
Sr <sup>2+</sup>	---	0.03	---	---	---	---
Fe <sup>3+</sup>	0.00	0.17	---	0.00	0.09	0.01
Ti	0.00	---	---	---	0.13	0.01
Zr	---	0.08	---	---	---	---
Sr <sup>4+</sup>	0.00	0.35	---	0.00	0.30	0.03
Nb	0.78	1.11	---	1.04	1.28	1.51
Ta	7.22	5.47	8.00	6.88	5.52	6.37
	8.00	8.00	4.00	6.88	7.97	8.00
% Order	100	59(1)	100	100	88(1)	97(2)

- % order calculated using a wodginite structure - ixiolite structure mixing model.

TABLE 9. POLYHEDRAL EDGE LENGTHS (Å) FOR WODGINITE-GROUP MINERALS

	Wodginite (G69-17)	Partially Ordered Wodginite (CX-1)	M-LiTa <sub>3</sub> O <sub>8</sub> **	Lithio- wodginite (TSE-76)	Ferroan Wodginite (A-17)	Ferroan Wodginite (Heated) (A-17h)
<b>A Octahedron</b>						
O2 <sub>a</sub> - O2 <sub>a</sub>	3.40(2)	3.22(2)	3.39(4)	3.29(5)	3.29(2)	3.37(2)
O2 <sub>a</sub> g - O3 <sub>h,i</sub>	3.22(2)	3.14(2)	3.27(3)	3.11(5)	3.15(2)	3.23(2)
- O3 <sub>h</sub>	3.12(3)	3.04(2)	3.12(3)	2.85(4)	3.08(2)	3.13(2)
- O4 <sub>h</sub>	3.08(3)	2.98(3)	3.16(3)	3.18(5)	2.89(2)	3.05(2)
O3 <sub>h,i</sub> - O4 <sub>a,g</sub>	3.01(3)	2.96(2)	3.05(3)	2.98(5)	2.97(2)	2.99(2)
- O4 <sub>a,g</sub>	2.79(2)	2.73(2)	2.77(5)	2.85(4)	2.78(2)	2.77(2)
O4 <sub>a</sub> - O4 <sub>g</sub>	2.86(2)	2.78(2)	2.84(4)	2.83(6)	2.77(2)	2.75(2)
<O-O>	3.08	2.97	3.08	3.00	2.97	3.00
<b>B Octahedron</b>						
O1 <sub>a</sub> - O1 <sub>b</sub>	3.08(2)	3.17(3)	3.07(4)	3.23(5)	3.07(2)	3.10(3)
O1 <sub>a</sub> .b - O3 <sub>a,b</sub>	2.90(3)	2.88(2)	2.78(3)	3.01(5)	2.84(2)	2.82(2)
- O4 <sub>a,b</sub>	2.87(3)	3.02(3)	2.84(3)	2.87(4)	2.97(2)	2.95(2)
- O4 <sub>b,a</sub>	2.84(3)	2.92(3)	2.79(3)	2.88(4)	2.88(2)	2.92(2)
O3 <sub>a</sub> - O3 <sub>b</sub>	2.80(2)	2.72(2)	2.88(4)	2.85(5)	2.76(2)	2.73(2)
O3 <sub>a,b</sub> - O4 <sub>a,b</sub>	2.81(3)	2.85(2)	2.77(3)	3.06(4)	2.84(2)	2.80(2)
- O4 <sub>b,a</sub>	2.79(2)	2.73(2)	2.78(3)	2.85(4)	2.78(2)	2.77(2)
<O-O>	2.86	2.89	2.80	2.97	2.87	2.86
<b>C Octahedron</b>						
O1 <sub>c</sub> - O1 <sub>d</sub>	2.88(2)	2.87(3)	2.91(2)	2.91(3)	2.86(2)	2.87(3)
- O2 <sub>a</sub>	2.88(2)	2.90(3)	2.55(3)	2.53(3)	2.59(2)	2.53(2)
- O3 <sub>a</sub>	2.95(3)	2.98(3)	2.97(3)	2.78(4)	2.97(2)	2.98(2)
- O4 <sub>f</sub>	2.97(3)	2.93(3)	2.89(3)	2.92(4)	2.95(2)	2.91(2)
O1 <sub>d</sub> - O2 <sub>a</sub>	2.55(3)	2.80(3)	2.55(3)	2.53(3)	2.59(2)	2.53(2)
- O2 <sub>a</sub>	2.78(2)	2.77(3)	2.75(3)	2.79(3)	2.76(2)	2.74(2)
- O4 <sub>f</sub>	2.76(3)	2.76(3)	2.79(3)	2.80(6)	2.76(3)	2.78(2)
O2 <sub>a</sub> - O2 <sub>a</sub>	2.79(2)	2.87(2)	2.78(2)	2.73(2)	2.84(2)	2.79(2)
- O3 <sub>a</sub>	2.88(2)	2.94(2)	2.86(3)	2.84(5)	2.91(2)	2.87(2)
- O4 <sub>f</sub>	2.83(3)	2.89(2)	2.80(3)	2.91(4)	2.85(2)	2.84(2)
O2 <sub>a</sub> - O3 <sub>a</sub>	2.72(3)	2.89(2)	2.85(3)	2.56(6)	2.86(2)	2.84(2)
O3 <sub>a</sub> - O4 <sub>f</sub>	2.97(3)	3.04(2)	2.90(3)	3.03(5)	2.93(2)	2.95(2)
<O-O>	2.81	2.85	2.80	2.78	2.83	2.80

\* Ferguson *et al.* (1976)\*\* calculated from Gatehouse *et al.* (1976) and Santoro *et al.* (1977)

Interatomic distances and angles for the single-crystal experiments and for *M*-LiTa<sub>3</sub>O<sub>8</sub> were calculated with the program PARST (Nardelli 1983) in the CRYSRULER package of programs (Rizzoli *et al.* 1986); distances and angles for the Rietveld refinement were calculated with the program BADTEA (Finger 1969). The bond lengths for the various polyhedra are given in Table 7, bond angles are given in Table 8, and polyhedral edge-lengths are given in Table 9.

## DISCUSSION

In the discussions that follow, ionic radii are taken from Shannon (1976). Polyhedron distortion parameters used are  $\Delta$  (quadratic elongation =  $\Sigma(l_i - l_0)/l_0$ , where  $l_i$  is the individual bond-length,  $l_0$  refers to  $\langle l_i \rangle$ , and  $\sigma^2$ , the angle variance [ $\Sigma(\theta_i - 90)^2$ ];  $\theta = \text{O-M-O}$  bond angle), is taken from Robinson *et al.* (1971).

### Mean variations in bond lengths

As expected for close-packed oxide structures, the observed mean bond-lengths at all the sites in the wodginite structure are linear functions of the radius of constituent cations. Furthermore, inductive effects seem negligible, and a simple hard-sphere model (Fig. 3) serves to predict the observed

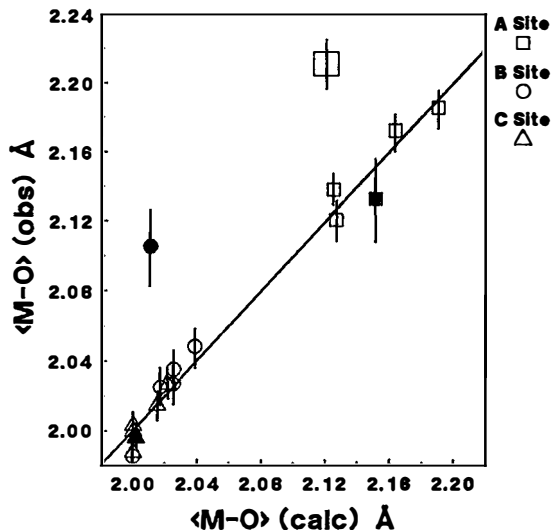

FIG. 3. Observed versus calculated mean bond-lengths for all refined structures of wodginite-group minerals. For this figure, and ones to follow, data for sample TSE-76 are coded as filled symbols; data for the *A* octahedron of the compound *M*-LiTa<sub>3</sub>O<sub>8</sub> are coded as oversized symbols. The line drawn is not a least-squares fit, but denotes a 1:1 relationship.

mean bond-lengths at all sites quite well. The one exception to this well-behaved relationship is the *A* polyhedron of *M*-LiTa<sub>3</sub>O<sub>8</sub> and the *B* polyhedron of wodginite TSE-76. The distinguishing characteristic of these two structures is the presence of significant amounts of Li.

The mean bond-lengths for the *B* and *C* polyhedra are practically identical, which in part accounts for the phenomenon of Ta disorder between the *B* and *C* sites. For all of the samples, the mean bond-lengths for the *A* polyhedron are distinctly larger than those for the *B* and *C* polyhedra; however, as one would expect, this distinction is less for the partially ordered samples (grand mean deviation: 0.10 Å) than in ordered ones (grand mean deviation: 0.16 Å).

### Individual variations in bond length

Figure 4 shows the relationship between the ionic radii of the constituents at the *A*, *B* and *C* sites (calculated from Table 6) and the individual bond-lengths for their corresponding coordination polyhedra. Comparison among Figures 4a, 4b and 4c shows that bond lengths for Li-poor members of the wodginite group vary linearly with ionic radius. However, the bond lengths for Li-rich members of the group deviate considerably from



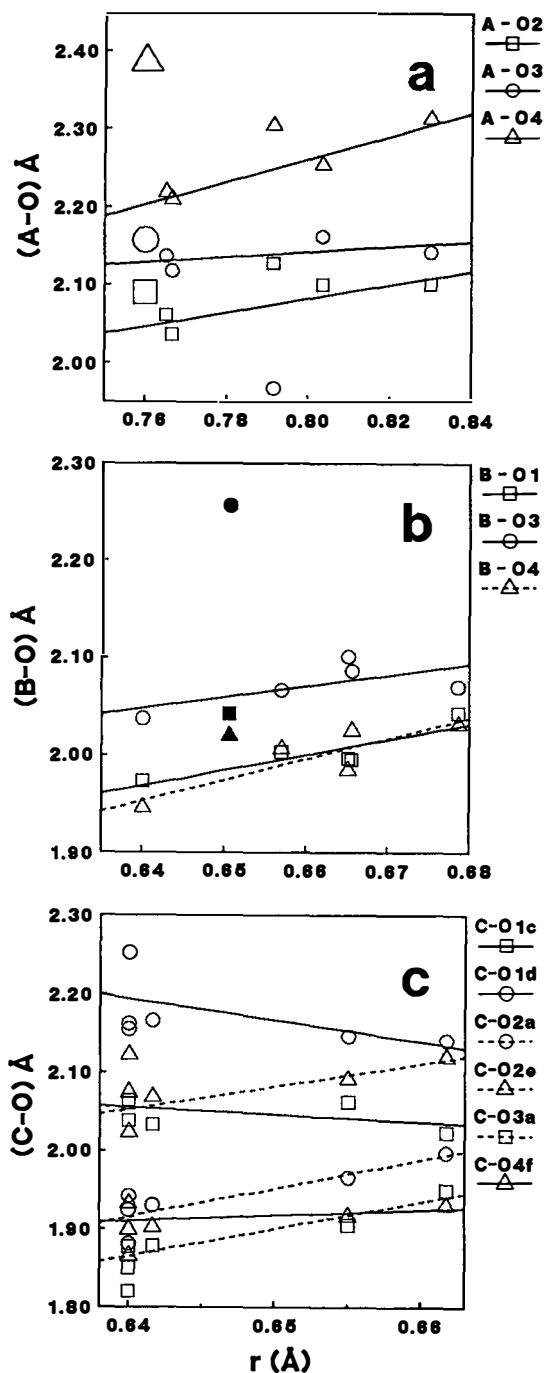

FIG. 4. Individual bond-lengths versus constituent ionic radii for the *A* octahedron (a), *B* octahedron (b), and the *C* octahedron (c); the coding of symbols is as in Figure 3. The regression curves for the *A* octahedron are for Li-poor samples only; regression curves for the *B* and *C* octahedra are based on all data except those for sample TSE-76.

the trends shown by the Li-poor compositions in the following ways:

(1) Sample TSE-76 deviates most from the trends shown by Li-poor compositions, and does so for all polyhedra; however, only one set of values for TSE-76 actually deviates significantly from the trends, those bond lengths involving O3. Sample TSE-76 is compositionally intermediate to wodginite ( $\text{MnSnTa}_2\text{O}_8$ ) and lithiowodginite ( $\text{LiTaTa}_2\text{O}_8$ ), but it does not have structural properties involving O3 that are intermediate between wodginite (G69-17) and synthetic lithiowodginite ( $M\text{-LiTa}_3\text{O}_8$ ). We thus conclude that the O3 position for sample TSE-76 is systematically in error owing to probable inadequacies in the Rietveld refinement.

(2) Bond lengths for the *B* and *C* polyhedra (Figs. 4b, c) of  $M\text{-LiTa}_3\text{O}_8$  follow the trends shown for Li-poor wodginite, as do most of the bond lengths for the *A* polyhedron; however, the *A*-O4 bond length deviates from the trend by  $6\sigma$  (Fig. 4a). The *A* octahedron shows additional anomalous behavior, which suggests that this deviation is real. First, the anomaly in bond lengths for the *A* octahedron is paralleled by anomalous edge-lengths for the octahedron; Figure 5 shows that the mean edge-length for the *A* polyhedron in  $M\text{-LiTa}_3\text{O}_8$  is unusually large compared to the effective ionic radius of the *A*-site constituent (Li). As the oxygen positions reported for  $M\text{-LiTa}_3\text{O}_8$  were taken from the single-crystal structure refinement (Gatehouse *et al.* 1976), deviations in O-O separations for the *A* octahedron cannot be ascribed to failings of the Rietveld experiment. Second, anomalous behavior

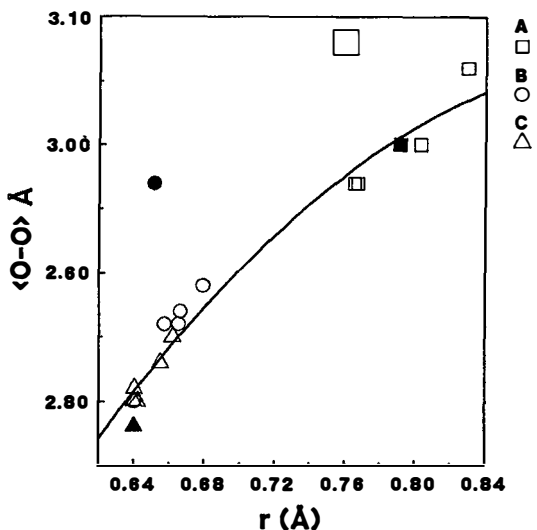

FIG. 5. Mean edge-lengths versus constituent ionic radii for the *A* octahedron. Symbol coding is as in Figure 3.

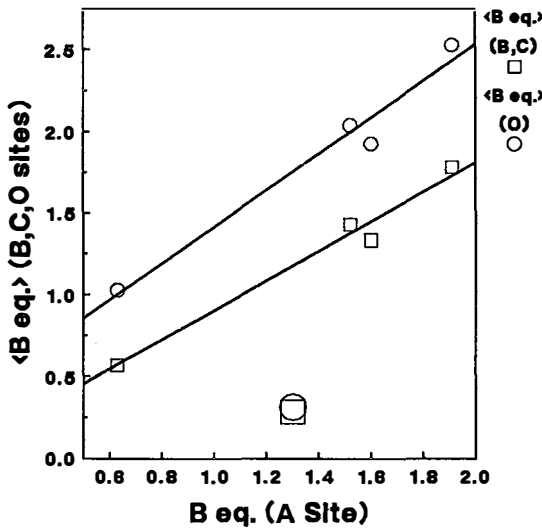

FIG. 6. Mean equivalent isotropic displacement-factor for the *B* and *C* cationic sites (squares) and oxygen sites (circles) versus that for the *A* site for all refined structures of wodginite. Data for sample TSE-76 are necessarily excluded, as displacement parameters were not refined for this structure. Symbol coding is as in Figure 3.

for the *A* octahedron in  $M\text{-LiTa}_3\text{O}_8$  also is shown by the displacement factors for the *A* cation (Fig. 6). Figure 6 indicates that Li-poor wodginite shows linear behavior with regards to the ratios of any one mean displacement-factor to another.  $M\text{-LiTa}_3\text{O}_8$  deviates from this trend: the refined displacement-factor for the *A* site is 5 to 6 times larger than all other displacement-factors. Considering all lines of evidence for  $M\text{-LiTa}_3\text{O}_8$ , the anomalous behavior associated with the Li atom and its coordination polyhedron seems real.

We may summarize the principal features of the anomalous behavior of the *A* (i.e., Li) site in  $M\text{-LiTa}_3\text{O}_8$  as follows: (i) the  $\langle A\text{-O} \rangle$  distance is anomalously large relative to that expected for Li as a constituent cation, and (ii) the refined equivalent displacement-factor is anomalously large. Both of these features may be accounted for by disorder of Li off the central *A* position. Thus the structure is unable to relax sufficiently around such a small cation as Li to allow it to occupy a central position.

Bond valences were calculated from the bond lengths using the constants of Ercit (1986) for Ta ( $R_0 = 1.927$ ,  $N = 6.4$ ) and Nb ( $R_0 = 1.907$ ,  $N = 4.4$ ), and the constants of Brown (1981) for all other cations. The bond valences are given in Table 10, and represent weighted averages based on the proportions of the various cationic constituents at

TABLE 10. BOND VALENCES ( $\nu_{\text{Lu}}$ ) FOR WODGINITE-GROUP MINERALS

	Wodginite (G69-17)	Partially Ordered Wodginite (CX-1)	$M\text{-LiTa}_3\text{O}_8$ **	Lithio- wodginite (TSE-76)	Ferroan Wodginite (A-17)	Ferroan Wodginite (Heated) (A-17h)
A - O <sub>2a,g</sub> $\times 2$	0.42	0.54	0.19	0.27	0.50	0.41
O <sub>3h,l</sub> $\times 2$	0.38	0.43	0.16	0.41	0.40	0.34
O <sub>4o,g</sub> $\times 2$	0.24	0.34	0.10	0.16	0.32	0.27
B - O <sub>1a,b</sub> $\times 2$	0.76	0.64	0.67	0.69	0.74	0.72
O <sub>3a,b</sub> $\times 2$	0.54	0.59	0.69	0.35	0.55	0.58
O <sub>4a,b</sub> $\times 2$	0.82	0.67	0.93	0.75	0.67	0.72
C - O <sub>1c</sub>	0.65	0.71	0.65	0.71	0.64	0.72
O <sub>1d</sub>	0.49	0.50	0.37	0.50	0.50	0.49
O <sub>2a</sub>	0.95	0.78	1.17	1.00	0.85	0.98
O <sub>2b</sub>	0.63	0.53	0.74	0.55	0.59	0.65
O <sub>3a</sub>	1.17	0.69	1.30	1.41	1.03	1.16
O <sub>4f</sub>	1.09	0.94	0.99	1.22	0.99	1.07
Site Sums						
A: $\Sigma s$	2.07	2.61	0.91	1.71	2.45	2.04
$\Sigma +$	1.98	2.78	1.00	1.40	2.62	1.98
B: $\Sigma s$	4.28	3.79	5.00	3.57	3.91	4.06
$\Sigma +$	4.03	4.05	5.00	4.67	4.06	4.09
C: $\Sigma s$	4.96	4.34	5.20	5.39	4.59	5.08
$\Sigma +$	5.00	4.57	5.00	5.00	4.66	4.97
O1:	1.92	1.85	1.89	1.90	1.88	1.93
O2:	2.00	1.64	2.10	1.83	1.93	2.03
O3:	2.09	1.90	2.16	2.17	1.98	2.08
O4:	2.15	1.95	2.02	2.14	1.99	2.06

\* Ferguson et al. (1976); \*\* Gadehouse et al. (1976) and Santoro et al. (1977)  
 $\Sigma +$ : sum of the formal cation charges for site occupancies  
 $\Sigma s$ : sum of the bond valences

a given site (Table 8). Inspection of Table 10 shows that the sums at the various sites agree quite well with the aggregate charges at these various sites based on the refined site-occupancies. The only major discrepancy occurs for lithiowodginite, in which the charge at the *B* site is significantly underestimated by the bond-valence summation.

### Polyhedral distortions

In addition to differences in bond lengths, there are significant differences in angular distortion of the polyhedra (Table 11). The *A* octahedron is the most distorted; the style of distortion (elongation of the *A*-O<sub>4</sub> bond, shortening of the shared polyhedral edge) is compatible with displacement of the relatively weakly bonded *A* cation from the geometric center of its polyhedron due to *A*-*B* repulsion within the [*A*,*B*] zig-zag chains of the wodginite structure. The *C* octahedron is marginally less distorted than the *A* octahedron in terms of

TABLE 11. POLYHEDRAL DISTORTION IN WODGINITE-GROUP MINERALS

Site	Wodginite (G69-17)	$M\text{-LiTa}_3\text{O}_8$ **	Lithio- wodginite (TSE-76)	Ferroan Wodginite (Heated) (A-17h)	Ferroan Wodginite (A-17)	Partially Ordered Wodginite (CX-1)
A	$\Delta$	18	33	42	8	11
	$\sigma^2$	94	118	50	87	87
B	$\Delta$	7	4	26	2	3
	$\sigma^2$	23	26	46	28	40
C	$\Delta$	27	45	40	26	15
	$\sigma^2$	73	79	108	72	60

$\Delta = 1/n \Sigma [(\theta_i - \theta_0)/\theta_0] / x_0 \times 10^4$  where  $\theta_0 = 1/n \Sigma \theta_i$   
 $\sigma^2 = 1/n \Sigma (\theta_i - \theta_0)^2$  where  $\theta_0 = 1/n \Sigma \theta_i$

$\sigma^2$ , and marginally more distorted in terms of  $\Delta$ . Distortion of the  $C$  octahedron can also be interpreted as due to  $C-C$  repulsion within the zig-zag chains that contain only  $C$  octahedra. The least-distorted polyhedron is the  $B$  octahedron; it is presumably less distorted than the  $A$  octahedron owing to the differences in bond strength between  $B-O$  bonds (Pauling bond-strength of 4/6 v.u. for  $\text{Sn}^{4+}$ ) versus  $A-O$  bonds (Pauling bond-strength of 2/6 v.u. for  $\text{Mn}^{2+}$ ) in the  $A, B$  zig-zag chains.

Polyhedral distortion also varies with the degree of order; coordination polyhedra of partially ordered members of the wodginite group tend to be less distorted than those of ordered members, an observation that holds both for single samples (e.g., heated and unheated sample A-17) and for the data set as a whole (the grand mean values of  $\Delta$ ,  $\sigma^2$  for samples of partially ordered wodginite are 10, 54; for samples of ordered wodginite, they are 23, 67).

### Symmetry aspects of cation order

The details of the structural relationships among ixiolite, tantalite and wodginite were summarized by Grice *et al.* (1976); Figure 7 shows the relationships among the unit cells of these three minerals. It is immediately apparent from Figure 7 that there is a very strong interaction between cell size, cell shape, space-group symmetry and patterns of cation order; it is worthwhile to explore these relationships further.

Ixiolite has space-group symmetry  $Pbcn$  and a completely disordered distribution of cations. In principle, some ordering of cations is possible in

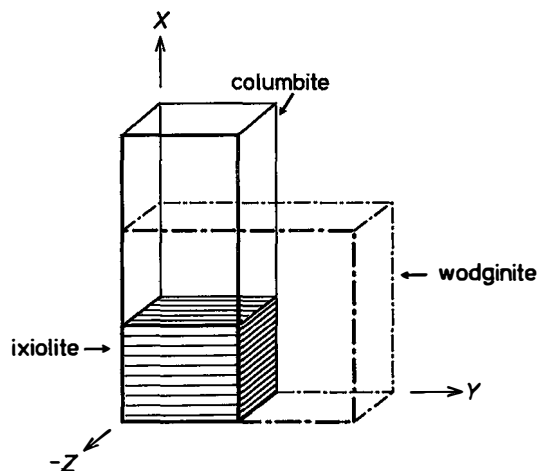

FIG. 7. Orientation and volume relationships among the unit cells of the ixiolite (shaded), columbite (solid rule) and wodginite (broken rule) structures (after Grice *et al.* 1976).

TABLE 12. SUBGROUPS OF  $Pbcn$

Orthorhombic	Monoclinic			Unique Axis	Triclinic
$Pb2n$	$P2_1/b$	$P2_1/c$	$Pb^*$	(X)	$P\bar{1}$
$Pbc2_1$	$P2/c$	$P2$	$Pc$	(Y)	$P1$
$P2_1cn$	$P2_1/n$	$P2_1/c$	$Pn^*$	(Z)	
$P2_122_1$					

an ixiolite-like cell if the symmetry is reduced. However, in order for the general structural arrangement to be compatible with the lower symmetry, the possible space-groups are restricted to subgroups of  $Pbcn$ . These are given Table 12; note that there is no change in the size or shape of the unit cell. The content of the unit cell of ixiolite is  $[ABC_2O_8]$ , letting  $A$ ,  $B$  and  $C$  represent the crystal-chemically distinct types of cations common in these minerals. For complete order to occur in this cell, the minimum rank of an equipoint (of a special or general position) must be 1. This rules out all space groups except  $P2$ ,  $P\bar{1}$  and  $P1$ ; however, with these space-group symmetries, complete order in an  $[ABC_2O_8]$  ixiolite-like structure is possible.

The alternative possibility is to increase the size of the unit cell of the structure in order to accommodate cation order. However, there are still symmetry restrictions on this process: the space group of the resultant ordered structure must be a subgroup of the symmetry group of the "expanded" ixiolite prototype structure. Formally, we may express this as

$$G^o \in G^1 \cup \{T\}$$

where  $G^o$  is the symmetry of the ordered phase,  $G^1$  is the space-group symmetry of the prototype ixiolite ( $Pbcn$ ), and  $\{T\}$  is the collection of translations that map out the unit cell of the ordered phase from that of ixiolite. In order for  $G^o$  to be a space group, the ordering of cations must result in a loss of the simple translations in  $\{T\}$ ; however, combinations of translations can be retained, as these become lattice centerings in  $G^o$ . We may distinguish two situations with regard to the translations present in  $\{T\}$ : (i) the cell is increased by an even multiple in a specific direction; (ii) the cell is increased by an odd multiple in a specific direction (e.g., tripled). In the first case, we lose any element of translational symmetry (e.g.,  $2_1$ ,  $b$ ,  $n$ ) with a translational component in the direction of cell doubling or quadrupling. In the second case, the symmetry elements initially present in  $G^1$  are unaffected by the cell tripling. All possible groups for doubled, tripled and quadrupled unit-cells are shown in Table 13.

If the prototype cell is doubled, the minimum rank of an equipoint required for complete order of a wodginite-like composition  $2[ABC_2O_8]$  is 2. Of

TABLE 13. MULTIPLE-CELL SUBGROUPS OF *Pbcn*

Double Cell		
$2x, y, z$	<i>Pbc2<sub>1</sub></i> , <i>P2/c</i>	[ <i>Pb<sup>x</sup></i> , <i>Pc<sup>y</sup></i> , <i>P2<sub>1</sub><sup>x</sup></i> , <i>P2</i> , <i>P1</i> , <i>P1</i> ]
$x, 2y, z$	<i>P2<sub>1</sub>22<sub>1</sub></i> , <i>P2/c</i>	[ <i>P2<sub>1</sub><sup>x</sup></i> , <i>P2</i> , <i>P2<sub>1</sub><sup>x</sup></i> , <i>Pc</i> , <i>P1</i> , <i>P1</i> ]
$x, y, 2z$	<i>Pb2n</i> , <i>P2<sub>1</sub><sup>x</sup>/b</i>	[ <i>Pb<sup>x</sup></i> , <i>P2</i> , <i>Pn<sup>x</sup></i> , <i>P2<sub>1</sub><sup>x</sup></i> , <i>Pb</i> , <i>P1</i> , <i>P1</i> ]
Triple Cell		
$3x, y, z$	} <i>Pbcn</i> [ + all subgroups of <i>Pbcn</i> , see Table 12 ]	
$x, 3y, z$		
$x, y, 3z$		
Quadruple Cell		
$2x, 2y, z$	<i>C2/c</i>	[ <i>P2/c</i> , <i>C2</i> , <i>Cc</i> , <i>P2</i> , <i>Pc</i> , <i>C1</i> , <i>P1</i> , <i>C1</i> , <i>P1</i> ]
$2x, y, 2z$	<i>Bb<sup>x</sup></i> , <i>B2</i>	[ <i>Pb</i> , <i>P2</i> , <i>B1</i> , <i>P1</i> ]
$x, 2y, 2z$	<i>A2</i>	[ <i>P2</i> , <i>A1</i> , <i>P1</i> ]

the possible space-groups for a double cell (Table 13), *Pbc2<sub>1</sub>* has a minimum rank of an equipoint of 4, and thus is not a candidate for a possible structure. This leaves two orthorhombic (*P2<sub>1</sub>22<sub>1</sub>* and *Pb2n*) and two monoclinic (*P2/c* and *P2<sub>1</sub><sup>x</sup>/b*) space groups, together with all of the lower symmetries of the subgroups listed in Table 13.

If the prototype cell is tripled, the minimum rank of an equipoint required for complete order of a wodginite-like composition  $3[ABC_2O_8]$  is 1. Possible symmetries are *Pbcn* (Table 13) or any subgroup of *Pbcn* (Table 12), but the requirement in equipoint rank reduces this to *P2*, *P1* or *P1*. Note that the situation is much more convenient for order of a tantalite-like composition:  $3[ABC_2O_8] \rightarrow [A_3B_3C_6O_{24}] \rightarrow [(A_3B)(B_2C_6)O_{24}] \rightarrow [X_4Y_8O_{24}]$ , which can fit into *Pbcn* symmetry in an ordered fashion, as the minimum rank of an equipoint required for ordering is 4, as is the case for *Pbcn*.

If the prototype cell is quadrupled, then a larger number of structures seems possible, as the cell can be quadrupled in one direction or doubled in two directions. If the cell is quadrupled in one direction, the space-group symmetries arising from this are those listed under "Double Cell" in Table 13. However, the cell contents are now  $4[ABC_2O_8]$ , and the minimum rank of an equipoint required for complete order is 4; hence all space groups listed in Table 13 under this heading are possible for ordered structures. If the quadruple cell is produced by doubling in two directions, the possible space-group symmetries are *C2/c*, *Bb<sup>x</sup>*, *B2* and *A2*; the minimum rank of an equipoint required is 4, and thus all of these space groups are compatible with ordered arrangements of cations.

There are presumably two factors affecting the actual choice of the structure of wodginite, the drive for cation order, and the observation that a structure generally adopts the arrangement of

maximum symmetry consistent with its optimum pattern of order. Of course, the latter is occasionally modified by low-temperature (2nd order) displacive phase-transitions, but even these commonly involve additional ordering of cations or anions. Accordingly, we will restrict our attention to those structural possibilities that allow full cation order of an  $n[ABC_2O_8]$  composition with maximum symmetry, and will not consider any subgroup derivatives of these (*i.e.*, lower-symmetry monoclinic or triclinic symmetries). If we strictly adhere to the principle that the structure adopts the maximum symmetry consistent with full order, all possible space-groups for double-cell schemes must have a maximum rank of an equipoint of 4; this is the case for the orthorhombic space-groups and the centrosymmetric monoclinic space-groups. For the quadruple-cell schemes, equipoints in possible space-groups must have a maximum rank of 8; this is the case for  $(2x, 2y, z)C2/c$ , which is the observed scheme of order in wodginite. Double- and quadruple-cell schemes of order are shown in Figure 8. Note that for  $(x, 2y, z)P2_122_1$ , there must be two crystallographically distinct Ta positions; this is also the case for the other quadruple-cell patterns of order [the example of  $(x, 2y, z)P2_122_1$  is shown in Fig. 8], and presumably these schemes are not viable on account of their uneconomical use of symmetry.

What is very interesting about the four principal schemes of order in Figure 8 is that they are the four simplest patterns that can occur in this type of arrangement. We can summarize their principal features very simply:

$(2x, y, z)P2/c$ : all distinct cations ordered in different chains;

$(x, 2y, z)P2/c$ : *A* and *B* (Mn and Sn) alternate along chains on one level, Ta completely ordered at all chains on alternate levels;

$(x, y, 2z)Pb2n$ : only one distinct type of chain, ordered along *Z* in the sequence *A-C-B-C...*;

$(2x, 2y, z)C2/c$ : *A* and *B* (Mn and Sn) alternate along chains at one level, Ta completely ordered at all chains on alternate levels.

As there are no recorded examples of wodginite with *P2/c* or *Pb2n* symmetry, we must conclude that  $(2x, 2y, z)C2/c$  is the most stable pattern of order. There do not seem to be any obvious features of the schemes of order in Figure 8 that indicate *C2/c* to be the preferred arrangement. The most obvious feature on which to base an assessment of the patterns of order is the relative cation-cation repulsion, local association of high-charge cations presumably maximizing this particular energetic term. Arrangement  $(2x, y, z)P2/c$  has the maximum association of high-charge cations, both Ta-Ta and Sn-Sn coupling being at their maximum. Of the other three arrangements,  $(x, 2y, z)P2/c$  and  $(2x,$

DOUBLE-CELL ORDERINGQUADRUPLE-CELL ORDERING $(2x, 2y, z)C2/c$ 

FIG. 8. Selected arrangements of cation order for supercells of the ixiolite structure.

$2y, z)C2/c$  are very similar; in each arrangement, the chains are the same, the only difference being a  $1/2b$  displacement of the structure at each  $A-B$  level. Arrangement  $(x, y, 2z)Pb2n$  seems the most favorable from the point of cation repulsion, as it separates the Ta atoms from each other. Thus a simple argument of this sort cannot account for the sole occurrence of the  $(2x, 2y, z)C2/c$  structure for wodginite; more sophisticated calculations of energy seem necessary. These calculations, together with additional experimental and theoretical work on the order-disorder relations in this system, are currently under way.

## SUMMARY

- (1) The degree of cation order for wodginite-group minerals is variable. Partially ordered samples are structurally intermediate to wodginite and ixiolite.
- (2) With respect to structure refinements for

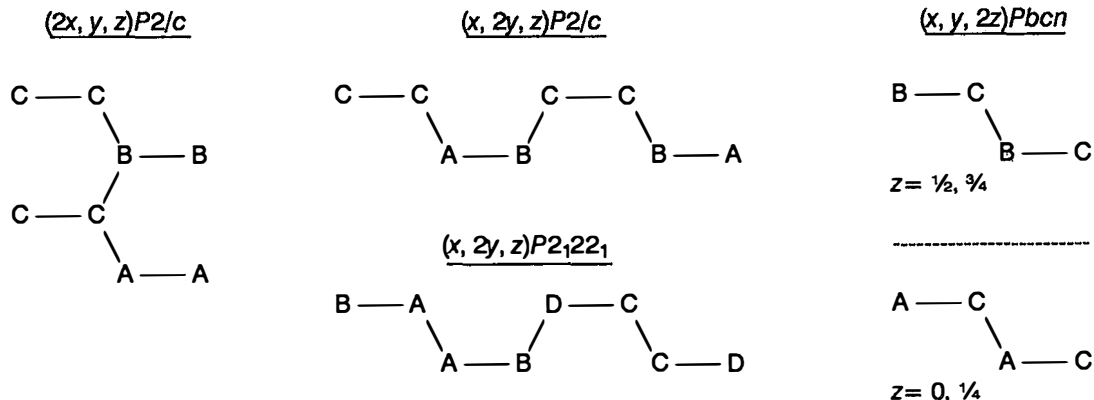
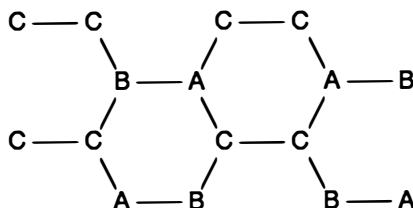
members of the wodginite group, the use of constraint equations involving a wodginite-ixiolite mixing model can give precise measures of the degree of cation order.

(3) The heating of samples under conventional conditions of  $1000^\circ\text{C}$  for 16 hours induces full order of cations in wodginite-group minerals.

(4) For both mean and individual bond-lengths, a simple hard-sphere model predicts compositional and structural variations well. However, Li-rich samples show deviations that seem to indicate that Li is disordered off the  $A$  position.

(5) For a wodginite-like  $ABC_2O_8$  composition, patterns of order involving an ixiolite subcell have been considered. Symmetry considerations for unit cells to four times the cell volume of ixiolite show four most probable patterns of order. Three of these are doubled cells; one is a quadrupled cell (wodginite structure). Only the quadrupled cell occurs naturally; because there is nothing obvious

about its scheme of order to indicate why the quadrupled cell is preferred, more sophisticated calculations of energy will be necessary to explain why only this variant occurs naturally.

#### ACKNOWLEDGEMENTS

We are grateful to J. Siivola and E.E. Foord for the use of some of the samples used in this study, A.C. Turnock for use of the quench furnace, and the Tantalum Mining Corporation of Canada Limited for access to the workings of the Tanco pegmatite during the period of study. Financial support for the study was in the form of NSERC operating and equipment grants and a Tantalum Mining Corporation of Canada contract to PC NSERC operating, major equipment and infrastructure grants to FCH, and a NSERC Postgraduate Scholarship, University of Manitoba fellowship and Canadian Museum of Nature research stipend to TSE. We thank the referees and R.F. Martin for helpful reviews of the paper.

#### REFERENCES

- BROWN, I.D. (1981): The bond-valence method: an empirical approach to chemical structure and bonding. *In* Structure and Bonding in Crystals II (M. O'Keefe & A. Navrotsky, eds.). Academic Press, New York.
- CROMER, D.T. & LIBERMAN, D. (1970): Relativistic calculation of anomalous scattering factors for X rays. *J. Chem. Phys.* **53**, 1891-1898.
- \_\_\_\_\_, & MANN, J.B. (1968): X-ray scattering factors computed from numerical Hartree-Fock wave functions. *Acta Crystallogr.* **A24**, 321-324.
- ELPHICK, P.M. (1972): *Crystal Structure Analysis of Wodginite from Bernic Lake, Manitoba*. M.Sc. thesis, Univ. Manitoba, Winnipeg, Manitoba.
- ERCIT, T.S. (1986): *The Simpsonite Paragenesis. The Crystal Chemistry and Geochemistry of Extreme Ta Fractionation*. Ph.D. thesis, Univ. Manitoba, Manitoba.
- \_\_\_\_\_, ČERNÝ, P. & HAWTHORNE, F.C. (1992b): The wodginite group. III. Classification and new species. *Can. Mineral.* **30**, 633-638.
- \_\_\_\_\_, \_\_\_\_\_, \_\_\_\_\_ & MCCAMMON, C.A. (1992a): The wodginite group. II. Crystal chemistry. *Can. Mineral.* **30**, 613-631.
- \_\_\_\_\_, HAWTHORNE, F.C. & ČERNÝ, P. (1986): The crystal structure of bobfergusonite. *Can. Mineral.* **24**, 605-614.
- FERGUSON, R.B., HAWTHORNE, F.C. & GRICE, J.D. (1976): The crystal structures of tantalite, ixiolite and wodginite from Bernic Lake, Manitoba. II. Wodginite. *Can. Mineral.* **14**, 550-560.
- FINGER, L.W. (1969): U M BADTEA. Geophysical Laboratory, Carnegie Institute of Washington (unpubl.).
- GATEHOUSE, B.M., NEGAS, T. & ROTH, R.S. (1976): The crystal structure of  $M\text{-LiTa}_3\text{O}_8$  and its relationship to the mineral wodginite. *J. Solid State Chem.* **18**, 1-7.
- GRAHAM, J. & THORNER, M.R. (1974): The crystal chemistry of complex niobium and tantalum oxides. II. Composition and structure of wodginite. *Am. Mineral.* **59**, 1040-1044.
- GRICE, J.D. (1973): *Crystal Structures of the Tantalum Oxide Minerals Tantalite and Wodginite, and of Millerite NiS*. Ph.D. thesis, Univ. Manitoba, Winnipeg, Manitoba.
- \_\_\_\_\_, FERGUSON, R.B. & HAWTHORNE, F.C. (1976): The crystal structures of tantalite, ixiolite and wodginite from Bernic Lake, Manitoba. I. Tantalite and ixiolite. *Can. Mineral.* **14**, 540-549.
- HILL, R.J. & HOWARD, C.J. (1986): A computer program for Rietveld analysis of fixed wavelength X-ray and neutron powder diffraction patterns. *Aust. Atom. Energy Comm., Lucas Heights Res. Lab. (Menai, NSW, Australia), Rep. M112*.
- \_\_\_\_\_, & MADSEN, I.C. (1984): The effect of profile step counting time on the determination of crystal structure parameters by X-ray Rietveld Analysis. *J. Appl. Crystallogr.* **17**, 297-306.
- LAHTI, S.I. (1982): A new pseudo-orthorhombic wodginite variety from the Erajarvi pegmatite area. *Geologi* **34**(1), 6-7 (in Finnish).
- MAKSIMOVA, N.V. & KHVOSTOVA, V.A. (1970): Mineralogy and crystal chemistry of some tantaloniobates. *Dokl. Acad. Sci. USSR* **193**, 119-122.
- NARDELLI, M. (1983): PARST: a system of Fortran routines for calculating molecular structure parameters from results of crystal structure analysis. *Comput. & Chem.* **7**, 95-98.
- NICKEL, E.H., ROWLAND, J.F. & MCADAM, R.C. (1963): Wodginite - a new tin-manganese tantalate from Wodgina, Australia and Bernic Lake, Manitoba. *Can. Mineral.* **7**, 390-402.
- PAULING, L. (1929): The principles determining the structure of complex ionic crystals. *J. Am. Chem. Soc.* **51**, 1010-1026.
- POLYAKOV, V.O. & CHEREPIVSKAYA, G.E. (1981): Ixiolite from the Ilmen Mountains. *Mineral. Zh.* **1**, 67-75 (in Russ.).
- RIZZOLI, C., SANGERMANO, V., CALESTANI, G. &

- ANDRETTI, G.D. (1986): CRYSRULER Package Version 1.0. Univ. Degli Studi di Parma, Parma, Italy.
- ROBINSON, K., GIBBS, G.V. & RIBBE, P.H. (1971): Quadratic elongation: a quantitative measure of distortion in coordination polyhedra. *Science* **172**, 567-570.
- SANTORO, A., ROTH, R.S. & MINOR, D. (1977): Neutron powder diffraction study of the intermediate-temperature form of lithium tantalate. *Acta Crystallogr.* **A32**, 751-767.
- SHANNON, R.D. (1976): Revised effective ionic radii and systematic studies of interatomic distances in halides and chalcogenides. *Acta Crystallogr.* **A32**, 751-767.
- SHELDRICK, G.M. (1976): SHELX76. A Program for Crystal Structure Determination. Univ. of Cambridge, Cambridge, England.
- WILES, D.B. & YOUNG, R.A. (1981): A new computer program for Rietveld analysis of X-ray powder diffraction patterns. *J. Appl. Crystallogr.* **14**, 149-151.

*Received June 26, 1991, revised manuscript accepted May 21, 1992.*