

nitrogen or hydrogen was activated alone. No hydrazine was found under any conditions. Considerations are presented showing that at low pressures ammonia would be expected, if at all, only when both the nitrogen and hydrogen are activated simultaneously and provided atomic nitrogen were present in the former. It is concluded that active nitrogen contains atomic nitrogen, which may be taken as support for the present interpretation of spectroscopic data. In addition it is concluded that glowing active nitrogen consists of a non-homogeneous mixture of nitrogen atoms and excited nitrogen molecules.

MINNEAPOLIS, MINNESOTA

[CONTRIBUTION FROM THE CHEMICAL LABORATORY OF THE UNIVERSITY OF CALIFORNIA]  
**THE SYSTEM WATER AND THE SULFATES OF SODIUM AND  
MAGNESIUM<sup>1</sup>**

BY WALTER C. BLASDALE AND HOMER L. ROBSON

RECEIVED SEPTEMBER 12, 1927

PUBLISHED JANUARY 5, 1928

In 1915 D'Ans<sup>2</sup> summarized the work of van't Hoff,<sup>3</sup> Roozeboom<sup>4</sup> and others on this system, and made sufficient new determinations to indicate the equilibrium relations in this system between 0 and 90°. The isotherm at 25° was determined by W. C. Blasdale in 1920 in connection with a study of the salt pair, sodium chloride—magnesium sulfate,<sup>5</sup> and the isotherm at 103° was similarly determined by Mayeda<sup>6</sup> in the same year. Archibald and Gale<sup>7</sup> in 1924 determined isotherms of this system at 0°, 10°, 18.7°, 25°, 30°, 40°, 50°, 60°, 80° and 100°, combining new determinations with the results of previous investigators. Their isotherms below 60° are in very fair agreement with those given by D'Ans, but those at 80 and 100° differ considerably. Mayeda's measurements disagree with those of D'Ans and of Archibald and Gale and are somewhat different from the values given in this paper.

The salts which occur below 60° are: the dodecahydrate, heptahydrate and hexahydrate of magnesium sulfate; sodium sulfate, decahydrate and

<sup>1</sup> A part of this work was done under a grant made by the University of Saskatchewan from its research fund.

<sup>2</sup> D'Ans, *Kali*, 9, 177 (1915).

<sup>3</sup> Van't Hoff, *Rec. trav. chim.*, 6, 36 (1887); (b) van't Hoff and van Deventer, *Z. physik. Chem.*, 1, 170 (1887); (c) van't Hoff and Meyerhoffer, *Sitzb. preuss. Akad. Wiss.*, Berlin, 1904, p. 1418; (d) van't Hoff, "Untersuchungen über der Bildungsverhältnisse der Ozeanischen Salzablagerungen," 1912 ed., p. 281; (e) van't Hoff and O'Farrelly, *Sitzb. preuss. Akad. Wiss.*, Berlin, 1902, p. 370; (f) "Untersuchungen," p. 198.

<sup>4</sup> (a) Roozeboom, *Rec. trav. chim.*, 6, 333 (1887); (b) Roozeboom, *Z. physik. Chem.*, 2, 513 (1888).

<sup>5</sup> Blasdale, *J. Ind. Eng. Chem.*, 12, 164 (1920).

<sup>6</sup> Mayeda, *J. Chem. Ind. (Japan)*, 23, 573 (1920).

<sup>7</sup> Archibald and Gale, *THIS JOURNAL*, 46, 1760 (1924).

anhydrous; and the double salt, astrakanite ( $\text{MgSO}_4 \cdot \text{Na}_2\text{SO}_4 \cdot 4\text{H}_2\text{O}$ ). We have found that these salts come to equilibrium with their aqueous solutions with reasonable rapidity. Above  $60^\circ$  löweite ( $\text{MgSO}_4 \cdot \text{Na}_2\text{SO}_4 \cdot 2\frac{1}{5}\text{H}_2\text{O}$ ), vanthoffite ( $\text{MgSO}_4 \cdot 3\text{Na}_2\text{SO}_4$ ) and kieserite ( $\text{MgSO}_4 \cdot \text{H}_2\text{O}$ ) occur. These salts come to equilibrium much more slowly and easily form super-saturated solutions. This is probably the cause of the disagreement of previous workers in this region.

We have made equilibrium measurements between  $67$  and  $100^\circ$ , including a determination of the isotherm at  $75$ ,  $85$ ,  $95$  and  $100^\circ$ , and have made sufficient measurements between  $100$  and  $210^\circ$  to indicate roughly the equilibrium relations within this temperature range. These measurements have been carefully compared with those of previous investigators and isotherms have been constructed for all temperatures for which data were available. Fig. 1 has been constructed from the isotherms as described below. From this figure the composition of any stable solution in this system may be found for the temperature interval  $0$  to  $210^\circ$ .

The heavy lines in Fig. 1 represent univariant systems and form a figure similar to that employed by D'Ans. They give the composition of solutions in equilibrium with two solid phases; the points which they intersect give the composition of invariant solutions. Temperature is measured on the horizontal axis and the composition of the solution on two vertical axes, one extending above and one below the heavy horizontal line. The upper vertical axis gives the magnesium sulfate concentration of the solution in grams of magnesium sulfate per 100 g. of water, and the lower gives the concentration of sodium sulfate similarly expressed; therefore the magnesium sulfate concentration of any univariant solution may be found from the line representing it in the upper part of the diagram and the sodium sulfate concentration from the corresponding line in the lower part. The circles represent equilibrium measurements given in Table II.

The fine lines give the total concentration of salts in grams per 100 g. of water. From them the composition of any solution in equilibrium with a single salt may be determined. Thus, to find the sodium sulfate concentration of a solution in equilibrium with astrakanite at  $45^\circ$ , which contains 46 g. of magnesium sulfate per 100 g. of water, the point in the upper part of the diagram corresponding to 46 g. of magnesium sulfate at  $45^\circ$  would be found. This lies between the fine lines representing total salt concentrations of 56 and 57 g. per 100 g. of water, and a value of 56.7 is obtained by interpolation. As 46 g. of this is due to magnesium sulfate, the remaining 10.7 grams would be the concentration of sodium sulfate in the solution. In this manner isotherms can be constructed from this diagram for any temperature between  $0$  and  $210^\circ$ .

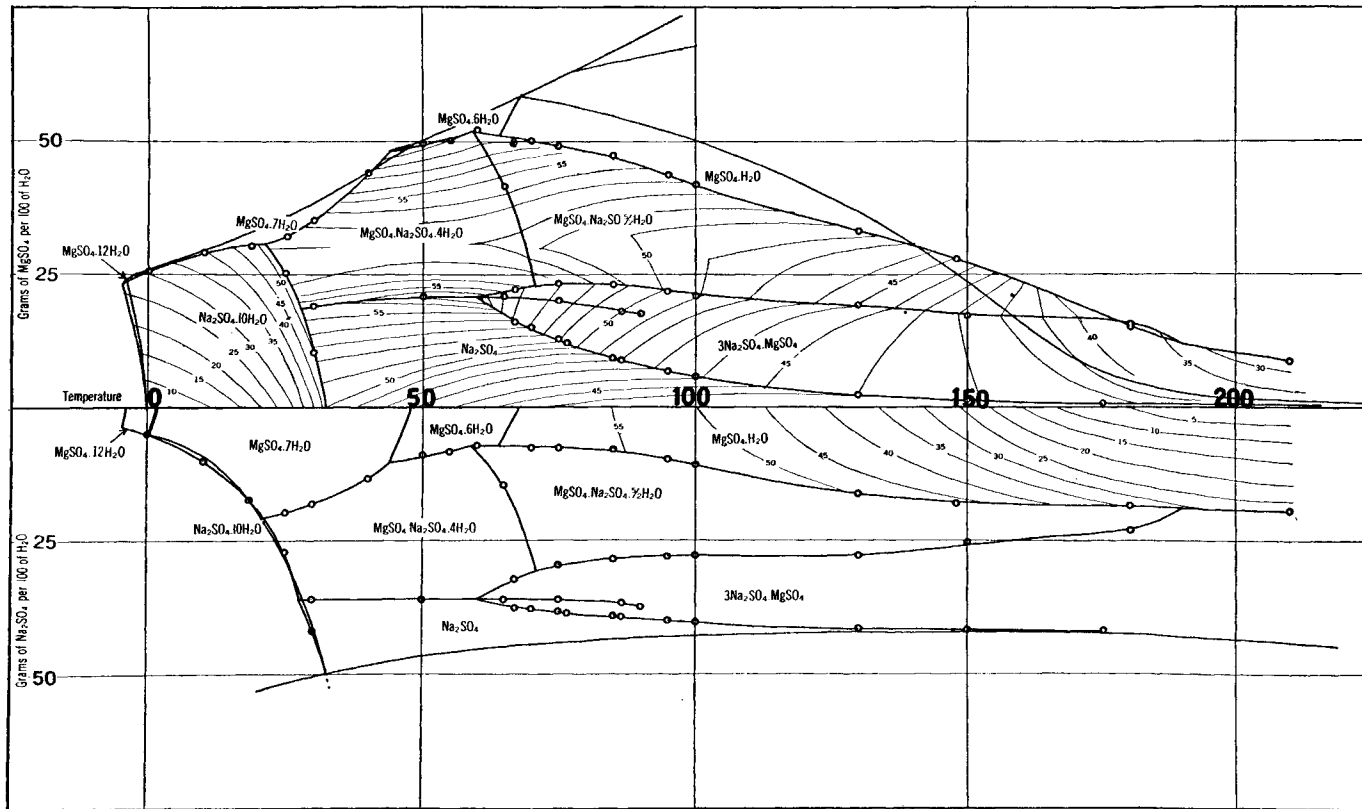

Fig. 1.—The system between  $-5$  and  $210^{\circ}$ .

In attempting to correlate the data of previous observers it was found advantageous to eliminate the water as a variable and to plot the per cent. of magnesium sulfate in the total anhydrous salts in the solutions against the temperature, according to the method of Jänecke.<sup>8</sup> Data which disagreed when plotted as isotherms or on a diagram, similar to Fig. 1 frequently agreed reasonably well when plotted on this type of diagram, a large part of the discrepancies being due to an error in the total salt concentration rather than in the ratio of magnesium sulfate to sodium sulfate in the solution. Smooth curves were drawn through the data on this diagram and these gave the ratio of magnesium sulfate to sodium sulfate in the univariant solutions. The data on the total salt concentration for each univariant system were then plotted against temperature and smooth lines drawn through the points, which met corresponding lines representing other univariant systems at the invariant points. From these two plots the compositions of the univariant systems were determined and plotted as the heavy lines of Fig. 1. Next, series of isotherms at intervals of 5 and 10° were made, based on the data for the univariant systems which had been determined as above described. The published measurements of Roozeboom and of Archibald and Gale and those which we determined were plotted on these isotherms and smooth lines drawn through the points. From the data given by these, the fine lines in Fig. 1 were constructed, alterations in the isotherms being made where necessary to avoid improbable distortion of the fine lines. The fine lines were placed at intervals of 5 g. of total salts per 100 g. of water in the areas representing solutions in equilibrium with sodium sulfate decahydrate and kieserite, as the diagram would be unduly complicated by placing them at unit intervals. Unit intervals are employed for the areas representing astrakanite, löweite, vanthoffite and thenardite (anhydrous sodium sulfate).

### Preparation of Salts

Commercially obtainable epsomite ( $\text{MgSO}_4 \cdot 7\text{H}_2\text{O}$ ), mirabilite ( $\text{Na}_2\text{SO}_4 \cdot 10\text{H}_2\text{O}$ ) and thenardite were employed for these salts and their filtered solutions for the preparation of the others. Magnesium sulfate hexahydrate is easily prepared by the evaporation of a solution of magnesium sulfate between 50 and 75°. Astrakanite was prepared by evaporating equimolecular solutions of the component salts at 50–55° and good crystals up to 1 cm. in length were grown from solutions at 60–95°. We did not succeed in growing single crystals at temperatures below 50° which were suitable for goniometer measurements.<sup>9</sup> Löweite was prepared by the slow evaporation of a

<sup>8</sup> Jänecke, *Z. anorg. Chem.*, **51**, 132 (1906). This method has been described by Blasdale, "Equilibrium in Saturated Salt Solutions," A. C. S. Monograph Series, **1927**, employing this system as an example. The diagram there given does not include the results of our measurements, which were unfinished at the time of writing.

<sup>9</sup> For data on the crystallography of astrakanite, see von Jeremejeff, *Z. Kryst.*, **23**, 269 (1891). In the literature this salt is also referred to as bloedite and as simonite, see Jaeger, *Tschermaks' Min. Pet. Mitt.*, **22**, 102 (1903).

solution containing magnesium and sodium sulfates in the molecular ratio of 3:2 at the boiling point, with additions of an equimolecular solution from time to time to maintain a constant composition of the solution. The precipitated salt was centrifuged and then pressed between filter paper while still warm. Each batch was analyzed and found to contain very little excess magnesium sulfate and nearly the theoretical water. A small amount of astrakanite was detected by microscopic examination. The presence of this small amount of astrakanite ordinarily does not matter and it can be removed by drying the salt in a partly closed vessel at 110° when necessary.

Vanthoffite was prepared by the slow evaporation of its congruent solution close to the boiling point, the solution being well seeded and vigorously agitated with a stream of compressed air. The salt was centrifuged and dried at 110°. It is very difficult to prepare this salt at temperatures below 95° as thenardite and astrakanite form more readily than the stable vanthoffite.

Kieserite was prepared by drying epsomite in air as described in a previous paper<sup>10</sup> and by stirring solutions of magnesium sulfate in contact with seed at 80–100°. The latter method gives a product which is very difficult to dry and is best stored wet at a temperature above 70°.

### Identification of Compounds

The solid phases in contact with the analyzed solutions were identified by analysis and by their optical properties, which are in Table I.<sup>11</sup>

TABLE I

Salt	OPTICAL PROPERTIES OF THE SALTS						System
	$\alpha$	$\beta$	$\gamma$	2V	Sign Disp.	Orientation	
Hexahydrate	1.438	1.463	1.465	29°	- $\rho > v$	Y = b, X $\wedge$ c -25°	Mono.
Kieserite	1.523	1.525	1.596	57°	+ $\rho > v$	Y = b, Z $\wedge$ c 76.5°	Mono.
Thenardite	1.464	1.474	1.485	84°	+ $\rho > v(w)$	X = b, Y = c	Ortho
Vanthoffite	1.485	1.488	1.489	84°?	- $\rho < v$	.....	Mono.?
Astrakanite	1.486	1.488	1.489	71°	- $\rho < v(\text{str.})$	Y = b, X $\wedge$ c 41.1°	Mono.
Löweite	...	1.471	1.490	Uni-axial	- ...	.....	Rhomboidal

Löweite is easily recognized by its uniaxial interference figure, hexahydrate by its figure and low index of refraction, and kieserite by its fine-grained structure and high index. Vanthoffite and astrakanite were difficult to distinguish and closely resemble thenardite from which they may be distinguished by their lower birefringence. The crystal form and optical orientation were frequently made use of. Many of the crushed fragments of thenardite have a diamond-shaped appearance, with an angle close to 60° (theor. 61° 44' for 110 $\wedge$ 1 $\bar{1}0$ ); vanthoffite forms some diamond-shaped crystals with a much sharper angle. Astrakanite occurs in laths and in combinations of the base, unit prism and dome (001, 110 and 101). The presence of vanthoffite, astrakanite and thenardite was verified by analysis or by means of a check on the salts added.

<sup>10</sup> Robson, THIS JOURNAL, 49, 2772 (1927).

<sup>11</sup> Larsen, "The Microscopic Identification of the Non-Opaque Minerals," Bulletin 679, U. S. Geological Survey, 1921. The data for magnesium sulfate hexahydrate are those given by Robson, ref. 10.

In examining the optical properties of the various solid phases a small portion was removed, rubbed dry on warmed blotting paper and examined with a petrographic microscope, employing suitable immersion media. When an analysis of the solid phase was required, 2-5 g. was removed from the solution and quickly dried with filter paper, weighed, made up to volume and analyzed. No attempt was made to employ the residue method of Schreinemakers.<sup>12</sup>

The presence of astrakanite in samples known to contain thenardite or löweite, and of vanthoffite in samples containing thenardite or löweite, was determined from the ratio of magnesium sulfate to water in the sample. All doubtful analyses were rejected. Vanthoffite and astrakanite would not occur together except along the univariant line between 60 and 71°.

In making many of the measurements the solid phases were first prepared and analyzed, weighed amounts added to the solubility tubes and a solution of the expected equilibrium concentration, prepared by the evaporation of standardized stock solutions of the two sulfates to a definite strength, was added. The volume was noted before and after stirring. Any alteration in the solid phases would have been readily detected by comparing the analysis of the final solution with the known amount of water and salts added to the tubes.

The optical examination of the solid phases greatly facilitated the preliminary work and gave positive identification in cases where other methods alone would have left some room for doubt.

### Transition Points

The transition point of magnesium sulfate dodecahydrate and heptahydrate was determined by Cottrel<sup>13</sup> to be 1.8° and the cryohydric point, dodecahydrate-ice-solution of magnesium sulfate, to be -3.9°. We assume that the corresponding point, dodecahydrate-mirabilite-ice-solution of sodium and magnesium sulfates, will be about -5° and the invariant point, dodecahydrate-mirabilite-epsomite-solution of sodium and magnesium sulfates, about 0°. The invariant point, epsomite-mirabilite-astrakanite-solution, was determined by van't Hoff<sup>1c</sup> thermometrically to be 20.6° and the invariant point, mirabilite-astrakanite-thenardite-solution, thermometrically by D'Ans<sup>2</sup> as 27°. The transition of epsomite to hexahydrate was found to occur at 48.4° by Carpenter and Jette,<sup>14</sup> and this temperature is probably lowered 4° by the presence of astrakanite. We determined the invariant point, hexahydrate-astrakanite-löweite-solution, dilatometrically, to be about 59.5°. Two tubes were employed, the first giving a contraction below 58.5° and an expansion above 60.5°, and

<sup>12</sup> Blasdale, ref. 8, page 86.

<sup>13</sup> Mentioned by van't Hoff, Meyerhoffer and Smith, *Sitzb. preuss. Akad. Wiss., Berlin, 1901*, p. 1035; "Untersuchungen," p. 173.

<sup>14</sup> Carpenter and Jette, *THIS JOURNAL*, 45, 578 (1923).

the second a contraction at  $59^\circ$  and an expansion at  $60.2^\circ$ . The invariant point, astrakanite-vanthenardite-solution, was found to be  $60^\circ$  by interpolation as the equilibrium was established so slowly it was not possible readily to determine the point by dilatometric or tensimetric methods. Van't Hoff, Meyerhoffer and Smith<sup>13</sup> found the transition of hexahydrate to kieserite to occur at  $68^\circ$  in contact with a solution of magnesium sulfate; the presence of löweite would probably lower this temperature by  $4^\circ$ . The invariant point, astrakanite-löweite-vanthenardite-solution, was found by van't Hoff and O'Farrelly<sup>3e</sup> to lie at  $71^\circ$  by dilatometric investigation.

The transition of löweite to vanthenardite and kieserite occurs above  $100^\circ$ . Jänecke<sup>15</sup> obtained seemingly conclusive evidence for a transition temperature between  $120$  and  $130^\circ$  with a strong expansion accompanying the transition. We were unable to verify his findings. Two Pyrex dilatometers, the lower portion of one of which is represented in Fig. 2, were employed, with balancing columns of mercury three meters high in a tube 0.8 mm. in diameter and a bulb of 60 cc. capacity. With these the region between  $115$  and  $137^\circ$  was explored very carefully and no expansion was observed. The tubes were loaded with finely powdered kieserite, löweite and vanthenardite, with about 10% of astrakanite to provide the proper solution on melting at  $71^\circ$ . These were exhausted rapidly at  $80^\circ$ , filled with paraffin oil (Nujol) and sealed off; after filling the arm with mercury they were brought to equilibrium at  $115$  and  $120^\circ$ , respectively. A slow contraction accompanied the conversion of the kieserite in the charge to löweite, and this was completed in three days at  $120^\circ$ . At the conclusion of the trial with the second dilatometer, which lasted three weeks, the bath was brought to  $120^\circ$  and the dilatometer gave the initial reading. The room temperature was kept within one degree of  $22^\circ$  for one half hour preceding measurements to avoid any effect of temperature on the mercury column. An expansion corresponding to the initial contraction could have been easily observed without this precaution.

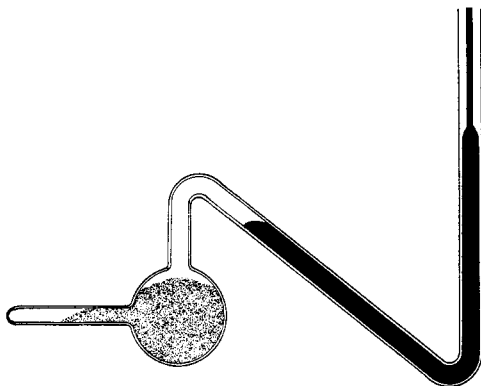

Fig. 2.—Cross section of lower portion of tensimeter.

This type of apparatus became awkward for making observations at higher temperatures than  $137^\circ$ , so experiments were continued employing

<sup>15</sup> Jänecke, *Kali*, 11, 12 (1917).

the solubility bomb described below. The bomb was charged with a saturated equimolecular sodium and magnesium sulfate solution and löweite, with a small amount of kieserite and vanthoffite as seed, and stirred at the required temperature for one or two days. At the conclusion of stirring the solution was drained from the solid phase by inverting the bomb and opening the valve until all the liquid had passed out; the bomb was then quickly opened and the solid phase examined with the petrographic microscope. Löweite was clearly detected in all mixtures stirred, up to 180°, but was replaced by vanthoffite and kieserite at 210°. The exact transition point, representing the equilibrium

$$3\text{MgSO}_4 \cdot \text{Na}_2\text{SO}_4 \cdot 5/2\text{H}_2\text{O} \longrightarrow \text{MgSO}_4 \cdot 3\text{Na}_2\text{SO}_4 + 2\text{MgSO}_4 \cdot \text{H}_2\text{O} + \text{solution}$$

was not determined, but probably lies close to 190°.

### Solubility Determination

The equilibrium determinations below the boiling point were made by stirring the mixtures of salt and water in tubes of Pyrex glass 4 cm.  $\times$  30 cm. with a screw stirrer 10 cm. long and 2.5 cm. wide. The stem of the stirrer was 0.8 cm. thick and 30 cm. long, and rotated in a Pyrex tube which passed through two close-fitting rubber stoppers, one at the top of the tube and one below the level of the oil in the bath. This arrangement prevented water from distilling out of the tube or condensing on the cooler portions inside it. Individual motor drives were found to be more satisfactory than a main pulley drive. A load of 150 g. of solution and 100 g. of salts was usually charged.

In the preliminary experiments the stirrers were driven at 150 r. p. m. With this speed of stirring, equilibrium was attained very slowly and in some cases variable results were obtained after several weeks of stirring. With a stirring speed of 1000 to 1500 r. p. m. equilibrium was attained much more rapidly. We did not observe any shift in the equilibrium with variation in the speed of stirring. Some experiments were made in which the proper amounts of thenardite and epsomite were added in lieu of vanthoffite and löweite, but the solutions obtained were supersaturated unless stirred for an impractical length of time.

The experiments above 100° were made with an apparatus similar to one already described,<sup>10</sup> except that a different head was made for the bomb. The diagram of the head is given in Fig. 3. The nipple of the condenser is fastened into the head by a threaded sleeve. The opening into which this fits is closed by a plug during stirring. The solution on passing the filter and needle valve had only to travel through 15 mm. before entering the nipple of the condenser, which is 3 mm. wide and 40 mm. long. This is attached to the main condenser tube, which is 10 mm. wide and 50 cm. long, the last 30 cm. being bent in the form of a U-tube, which was immersed in ice water during sampling. This arrangement has been



employed in working with solutions of potassium chloride and sulfate and has proven very satisfactory. Different filter disks (Alundum disks, mix R. A. 225, supplied by the Norton Co.) from those employed for the system magnesium sulfate-water were employed and these let a small amount of very finely-divided kieserite through, giving the mixtures a milky appearance. Only one-third by weight of the charge was solution, to avoid any possibility of supersaturation. The exact amount of error from the kieserite passing the filter was not determined, but measurements of the solubility of magnesium sulfate alone under similar conditions gave results very little above the known curve and the error is probably less than 2 g. of magnesium sulfate per 100 g. of water. Preliminary measurements showed that the solutions did not come to equilibrium between 100 and 175° very much faster than between 75 and 100°.

Solutions supersaturated with respect to vanthoffite were prepared by evaporating appropriate mixtures of the stock solutions of the two sulfates. These precipitated astrakanite spontaneously and came to equilibrium in two or three hours. If seeded with about 2% of vanthoffite and stirred rapidly, stable equilibrium was obtained in one or two days. Solutions supersaturated with respect to löweite came to equilibrium with it most rapidly when the ratio of sodium

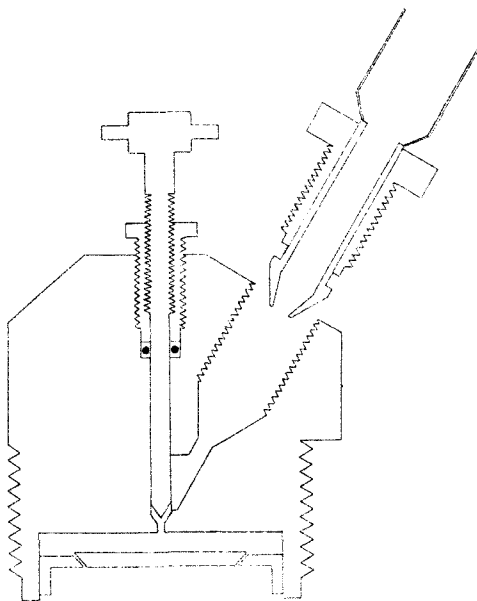
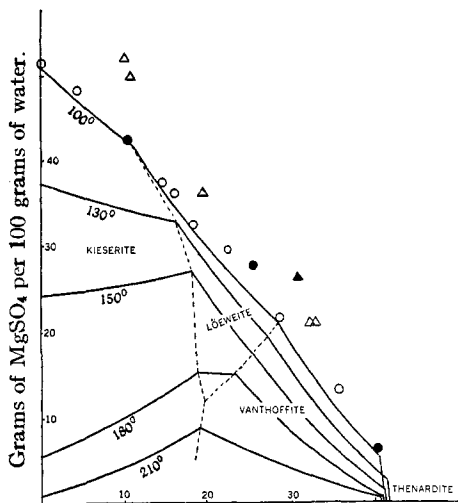

Fig. 3.—Cross section of upper part of bomb used for solubility determinations.

sulfate to magnesium sulfate approached that required for equilibrium with vanthoffite; those with a higher ratio of magnesium sulfate to sodium sulfate required one or two days' stirring before reaching equilibrium. Solutions containing up to 50% more magnesium sulfate than that required for equilibrium with kieserite were easily prepared by evaporation. These required four to six days' stirring in contact with 10-20% of seed to come to equilibrium.

The behavior of a solution upon evaporation may be predicted from Fig. 4, which gives the isotherms at 100, 130, 150, 180 and 210°. The measurements of Archibald and Gale at 100° and of Mayeda at 103° are given on this diagram; our data are not given individually. Unless

well seeded, the solution will be 10 to 20% supersaturated during concentration. Vanthoffite will not form under 95° unless a comparatively slow rate of concentration is employed. Appreciable amounts of kieserite



Grams of  $\text{Na}_2\text{SO}_4$  per 100 grams of water.  
 ○ Mayeda, 103°; △ Archibald and Gale, 100°;  
 ● ▲ Univariant points.

Fig. 4.—Isotherms of the system.

will form if solutions supersaturated with respect to it are boiled for three hours or more, but with rapid evaporation its formation should be negligible. We sampled several freely boiling solutions which had deposited 10% by weight of salts and found them to be slightly more supersaturated than would correspond to the isotherm given by Archibald and Gale.

The data are given in the table below. The first column gives the temperature and the second the reference, if the data are taken from previously published works. The third gives the experimentally determined fraction of magnesium sulfate of the

total anhydrous salts in solution and the following column gives the average of the values. The fifth column gives the average value for the total salts, as grams per 100 g. of water, obtained by drawing a smooth curve through available data, as previously explained. The last two columns give the grams per 100 g. of water of magnesium and sodium sulfates.

TABLE II  
 COMPOSITIONS OF UNIVARIANT SOLUTIONS  
 Solid Phases: Epsomite and Mirabilite

Temp., °C.	Observer	MgSO <sub>4</sub> in total solids	Av.	Total solids, g./100 g. H <sub>2</sub> O	MgSO <sub>4</sub> , g./100 g. H <sub>2</sub> O	Na <sub>2</sub> SO <sub>4</sub> , g./100 g. H <sub>2</sub> O
0		0.834	0.834	30.7	25.6	5.1
10	A. & G.	.737	.737	39.6	29.2	10.4
18.7	A. & G.	.635	.635	47.9	30.4	17.5
Solid Phases: Epsomite and Astrakanite						
25	W. C. B.	0.620	0.620	51.8	32.1	19.7
30	Roozeboom	.660	.660	53.5	35.3	18.2
40	A. & G.	.767	.767	57.5	44.1	13.4
Solid Phases: Mirabilite and Astrakanite						
25	W. C. B.	0.484	0.484	52.5	25.4	27.1
Solid Phases: Mirabilite and Thenardite						
30	A. & G.	0.199	0.199	52.5	10.4	42.1

TABLE II (Concluded)

Temp., °C.	Observer	Solid Phases: Hexahydrate and Astrakanite		Total solids,	MgSO <sub>4</sub> ,	Na <sub>2</sub> SO <sub>4</sub> ,
		MgSO <sub>4</sub> in total solids	Av.	g./100 g. H <sub>2</sub> O	g./100 g. H <sub>2</sub> O	g./100 g. H <sub>2</sub> O
50	A. & G.	0.847	0.847	58.6	49.6	9.0
55	D'Ans	.858	.858	58.5	50.2	8.3
60	A. & G.	.880	.880	59.5	52.4	7.1
Solid Phases: Thenardite and Astrakanite						
30	Roozeboom	0.346	0.346	55.2	19.1	36.1
50	A. & G.	.365	.365	57.2	20.9	36.3
65	D'Ans	.367	.367	57.2	21.0	36.2
75		.350 .351 .364	.356	56.2	20.0	36.2
86.5		.330 .329 .327	.329	54.7	18.0	36.7
90	D'Ans	.321	.321	55.2	17.7	37.5
Solid Phases: Astrakanite and Vanthoffite						
67		0.406	0.406	54.5	22.1	34.4
Solid Phases: Thenardite and Vanthoffite						
67		0.299	0.299	53.5	16.0	37.5
70		.284	.284	52.8	15.0	37.8
75		.250 .254	.252	51.0	12.8	38.4
76.5		.236 .236 .240	.237	50.6	12.0	38.6
85		.188 .195	.191	48.5	9.3	39.2
86.5		.183	.183	48.2	8.8	39.4
95		.142 .151 .139 .141	.143	46.7	6.7	40.0
100		.127	.127	46.0	5.8	40.2
130		.052	.052	44.0	2.3	41.7
150		.0271	.0271	43.2	1.4	41.8
175		.0165	.0165	42.4	0.7	41.7
Solid Phases: Kieserite and Löweite						
70		0.869	0.869	58.0	50.4	7.6
75		*864	.864	56.9	49.2	7.7
85		.845 .858 .860 .862	.855	55.3	47.3	8.0
95		.812 .815	.813	53.6	43.6	10.0
100		.789 .798	.793	52.7	41.8	10.9
130		.676 .666	.670	49.6	33.2	16.4
148		.605	.605	46.0	27.9	18.1
180		.451	.451	33.7	15.2	18.5
Solid Phases: Löweite and Vanthoffite						
75		0.435 .440 .443	0.440	53.1	23.4	29.7
85		.442 .447 .449 .450	.447	51.5	23.0	28.5
95		.438 .437 .436	.437	49.7	21.7	28.0
100		.428 .438	.430	48.9	21.0	27.9
130		.407 .409	.408	46.7	19.0	27.7
150		.405	.405	42.7	17.3	25.4
180		.403	.403	38.9	15.7	23.2
Solid Phases: Kieserite and Vanthoffite						
210		0.304	0.304	28.0	8.5	19.5

The values in the third column are in each case those experimentally determined. Where the data of other observers have been employed, the most satisfactory value has been given in the table; the others have been given consideration in the construction of the initial diagram and the isotherms. The values given in this table are plotted in Fig. 1. They are not entirely concordant but sufficiently so to justify the construction of this type of figure. Owing to the limited number of measurements, the data above  $100^{\circ}$  cannot be considered as accurate as those at temperatures below the boiling point.

### Summary

1. An apparatus has been developed with which equilibrium measurements in systems composed of two salts and water may be made at temperatures above the boiling point of the solution.

2. The literature relating to the system magnesium sulfate-sodium sulfate-water has been reviewed and presented along with new data obtained at temperatures between  $67$  and  $210^{\circ}$ .

3. The invariant point, löweite-hexahydrate-astrakanite-solution, has been found dilatometrically to lie close to  $59.5^{\circ}$ ; and the invariant point, löweite-kieserite-vanthoffite-solution, to lie between  $180$  and  $210^{\circ}$ .

4. It has been shown that the disagreement in the previous data on this system between temperatures of  $60$  and  $100^{\circ}$  was probably caused by the extreme slowness with which the stable double salts come to equilibrium with their solutions.

5. The identification of the salts occurring in this system by optical means has been discussed.

BERKELEY, CALIFORNIA

---

[CONTRIBUTION FROM THE CHEMICAL LABORATORY OF RUTGERS UNIVERSITY]

## THE VALUE OF THE HAGENBACH FACTOR IN THE DETERMINATION OF VISCOSITY BY THE EFFLUX METHOD

BY WILLIAM RIEMAN III

RECEIVED SEPTEMBER 19, 1927

PUBLISHED JANUARY 5, 1928

### Historical Introduction

For a more complete outline of the history of viscosity and in particular the value of the Hagenbach factor " $m$ " in the kinetic energy correction, the reader is referred to Bingham's "Fluidity and Plasticity."<sup>1</sup> It is necessary to emphasize here only the following points. Numerous investigators have attacked the problem from the theoretical point of view, and have derived results identical in all respects except that the value of the constant  $m$  differs. None of the authors (prior to Bienias and Sauer-

<sup>1</sup> Bingham, "Fluidity and Plasticity," McGraw-Hill Book Co., New York, 1922, pp. 1-21.